

AIR CONDITIONING SYSTEMS

# CITY MULTI



CM22AS-X

## CITY MULTI YKD-Series

# Further Enhanced Energy Saving

Saving energy is becoming ever more important all around the world. Mitsubishi Electric is at the forefront of this development, with advanced products that realize high-quality energy saving solutions for customers in all fields.

### **Energy saving key point 1** High rated performance

Compared to the conventional series, all models of the YKD series (8 to 60HP) are improved rated EER/COP. This means less energy will be consumed during peak hours, such as high-temperature periods in the daytime.

### **Energy saving key point 2** High partial-load performance

The YKD-Series surpass the conventional series not only in rated specifications but also in terms of partial-load performance. During mornings and evenings, when the temperature is lower and less cooling power is required, better efficiency also enables significant energy savings.

### **Energy saving key point 3** Energy saving assist function

The functions makes it possible to optimize energy saving performance by closely matching the requirements of the installation location. This makes it possible to achieve results that surpass the specifications of the product, contributing to truly energy-saving buildings.







## Contents

• <u>Advantages of CITY MULTI</u>	5 ~ 18P
• <u>Outdoor/Heat source unit</u>	19 ~ 98P
• <u>Indoor unit</u>	99 ~ 146P
• <u>Remote Controller</u>	147 ~ 174P
• <u>Lossnay</u>	175 ~ 192P
• <u>Installation information</u>	193 ~ 201P

## New release products

### **Outdoor unit** **S-series**

PUMY-CP VKM2(-BS)/PUMY-CP YKM2(-BS)/PUMY-CP YBM2(-BS)  
PUMY-SP VKM2/PUMY-SP YKM2(-BS)  
PUMY-P YKM3/PUMY-P YBM2(-BS)

### **Indoor unit**

PLFY-P140VEM-PA  
PMFY-P50/P63/P71VFM-PA  
PEFY-P VMA(L)-E4/PEFY-P VMA4-E

### **Remote controller**

PAR-41MAA

# The CITY MULTI VRF System provides more satisfactory air-conditioning systems with 6 advantages.

## 1. Energy-saving performance

Wasteful energy use can be prevented by operating the inverter according to the load and by using an intelligent power module.

## 2. Self-developed Compressor

Mitsubishi Electric has focused on in-house development of the compressor, the core component of the air conditioner. We have developed compressors that meet the specifications required by the air conditioner.

## 3. Own system control: M-NET

Mitsubishi Electric uses "M-NET", an original air-conditioner network system.

M-NET is a network that connects CITY MULTI air conditioners in a building through the use of transition wiring with 2 non-polar wires.

Control of air-conditioning units and fine control of each indoor unit is accomplished by connecting Mitsubishi Electric Air-conditioner Network System (MELANS) to M-NET.

## 4. Developed in Japan

The product concept and key parts of CITY MULTI, have been designed at Mitsubishi Electric Works in Japan. This comprises all of the highly technological developments over our long history in Japan.

## 5. Mitsubishi Electric Quality

CITY MULTI is produced under strict production controls. Production lines are controlled to prevent any minor errors by unique systems, such as "parts server", "Cart Navi".

## 6. Various applications

CITY MULTI can be installed in various types of buildings, such as residences, offices and hotels. A suitable model can be selected according to the situation of use.

### What is Variable Refrigerant Flow (VRF)?

VRF is characterized by the ability to connect multiple indoor units to one outdoor unit and control the indoor units individually. The outdoor unit uses an inverter-driven compressor and can change the refrigerant flow rate according to the indoor unit load.

Since the capacity range of the indoor unit is wide, air-conditioning of even small spaces is possible. Also, indoor units can be individually started, stopped, and controlled to regulate temperature, thereby leading to energy savings.



# Advantages of CITY MULTI

## Energy saving performance

The advantage of CITY MULTI from Mitsubishi Electric is its high energy efficiency, which leads to increased energy savings.

The energy-saving performance of CITY MULTI has been improved to a high level within the industry through technical innovation.

### Smart control for saving energy

The compressor varies its speed to match the indoor cooling or heating demand, thus it only consumes the amount of energy required. When an inverter driven system is operating at partial load, the energy efficiency of the system is significantly higher than that of a standard fixed speed, non inverter system.

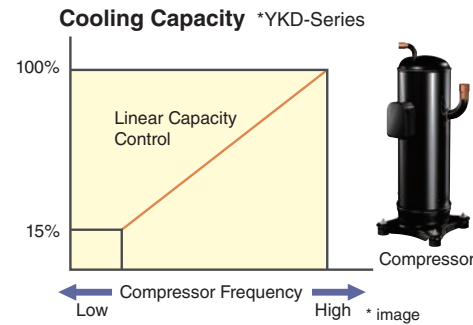

\* Values vary depending on actual conditions, such as ambient temperature.

### The Importance of Partial-Load Efficiency

The energy efficiency ratio (EER) is an index calculated at an ambient temperature of 35°C [95°F]. Actually, the temperature difference between day and night is large, even on hot days. Therefore, it is important to save energy across various temperatures where the EER cannot be measured perfectly. **CITY MULTI can achieve true energy savings by improving efficiency not only under rated conditions, but also under partial-load conditions.**

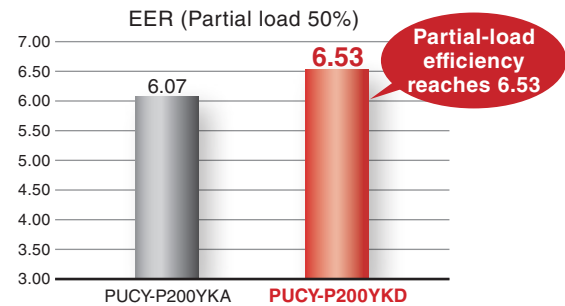

Temperature in Tokyo in 2021 (by month)

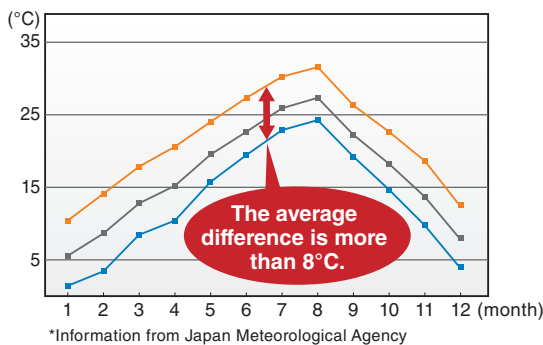

Temperature in Singapore in 2021 (by month)

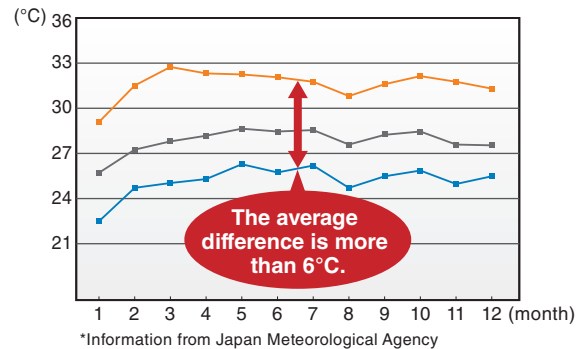

Legend: Mean daily maximum temperature average (orange line), Mean daily temperature average (grey line), Mean daily minimum temperature average (blue line)

### High rated performance

CITY MULTI's distinct advantage is its high energy efficiency, which leads to increased energy savings. One of the industry's highest level of energy-saving performance has been achieved through technical innovation.

Comparison of EER (Energy Efficiency Ratio) – 20 HP system

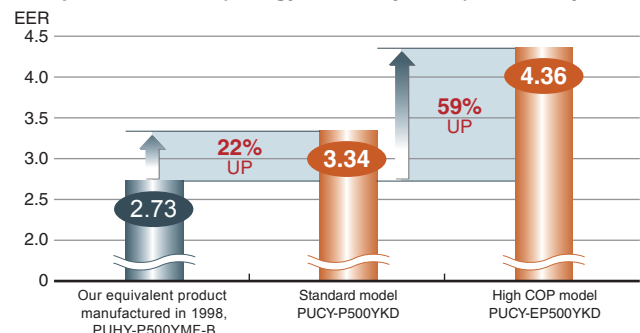

# Self-developed Compressor

The compressor is the heart of an air conditioner, contains inverter control. Mitsubishi Electric manages all compressor production processes, from development, design, and manufacture to quality control. We develop high-performance compressors to improve performance to a higher level.

## Key compressor parts designed by Mitsubishi Electric

Key parts of the compressor such as the scroll and motor (core) are designed by Mitsubishi Electric to increase the operation efficiency of the outdoor unit. In order to achieve energy saving operation while also improving reliability, a low-pressure shell compressor is used, resulting in stable long-term running performance.

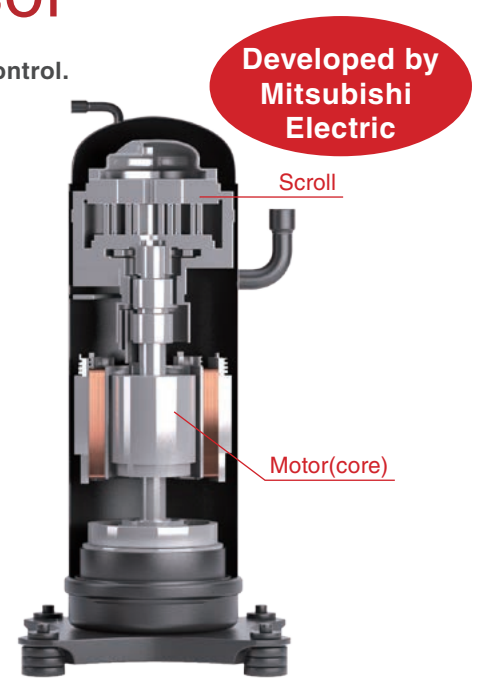

## High reliable low-pressure shells

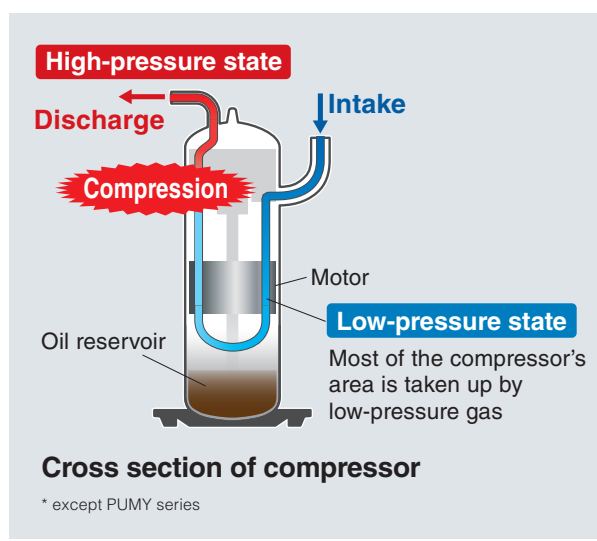

## Low-pressure shell compressor for top flow models

Most of the area in the compressor is taken up by the low-pressure gas. The refrigerant is drawn in from the side of the compressor and moves to the bottom of the shell where it flows to the scroll section and is compressed. The compressed high-pressure gas is discharged from the top of the compressor. **This prevents the motor and bearings from being heated up by the compressed high-pressure gas. The refrigerant is collected at the bottom of the shell to reduce the rate of compressor damage caused by liquid refrigerant compression.**

## Snap-in core

Mitsubishi Electric has incorporated a new and original production process that wraps a conductor directly around the split core to create a compact and highly efficient motor.

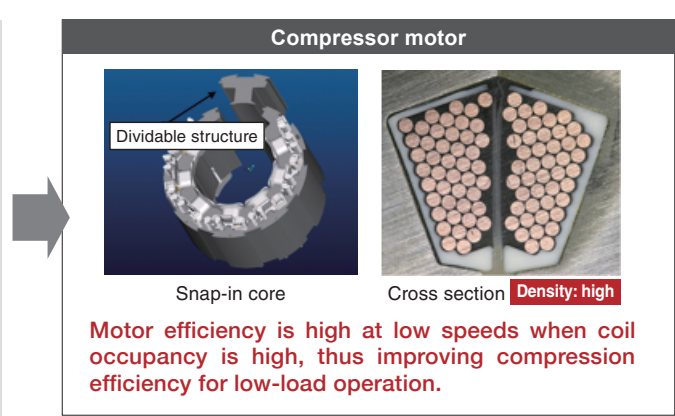
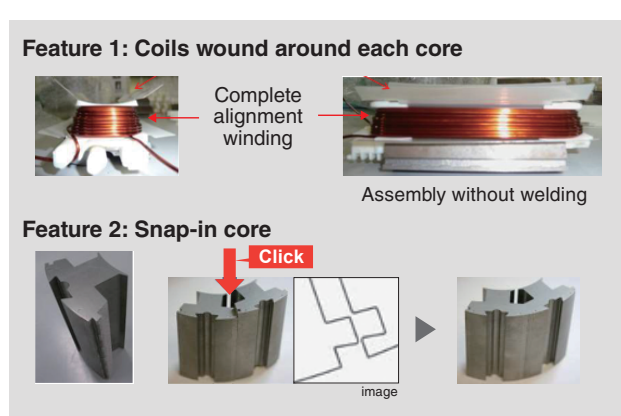

# Advantages of CITY MULTI

## Own system control: M-NET

A networked system called M-NET is used to control air conditioner operation. Air conditioners can be grouped and controlled appropriately for use by MELANS (Mitsubishi Electric Air-conditioner Network System), which centrally controls air-conditioning units on the network.

### Basic M-NET system

The basic M-NET system for multiple building air conditioners consists of outdoor units, indoor units and remote controllers. Outdoor units and indoor units are connected to M-NET through the "outdoor/indoor unit transmission line," and the indoor units and remote controllers are connected through the "remote controller line". Two types of local remote controllers are available: MA and ME. Numbers called M-NET addresses are assigned to outdoor units, indoor units, and local remote controllers, **thus allowing interaction via commands to operate the air conditioners and change settings.**

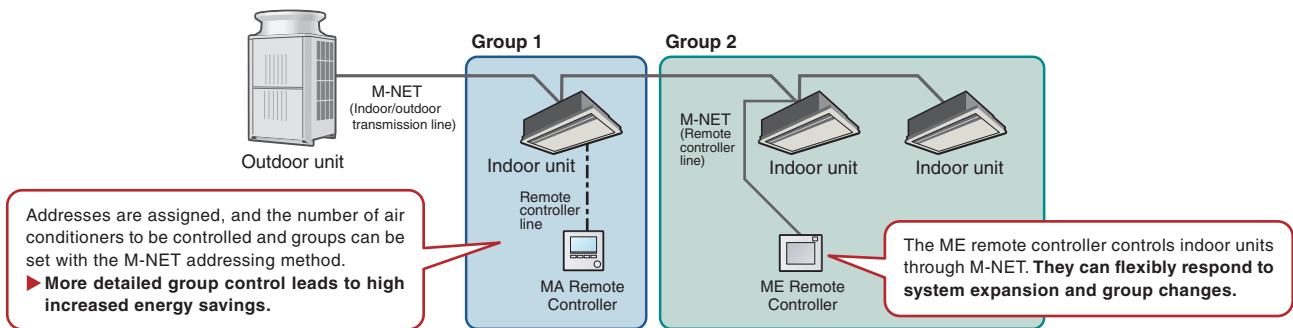

### System example

#### Centralized control using AE-200E

When one AE-200E unit is combined with the EW-50E expansion controller, up to 200 indoor units can be controlled. It is also possible to control operating time of the air conditioners to reduce the power consumption.

#### System Structure

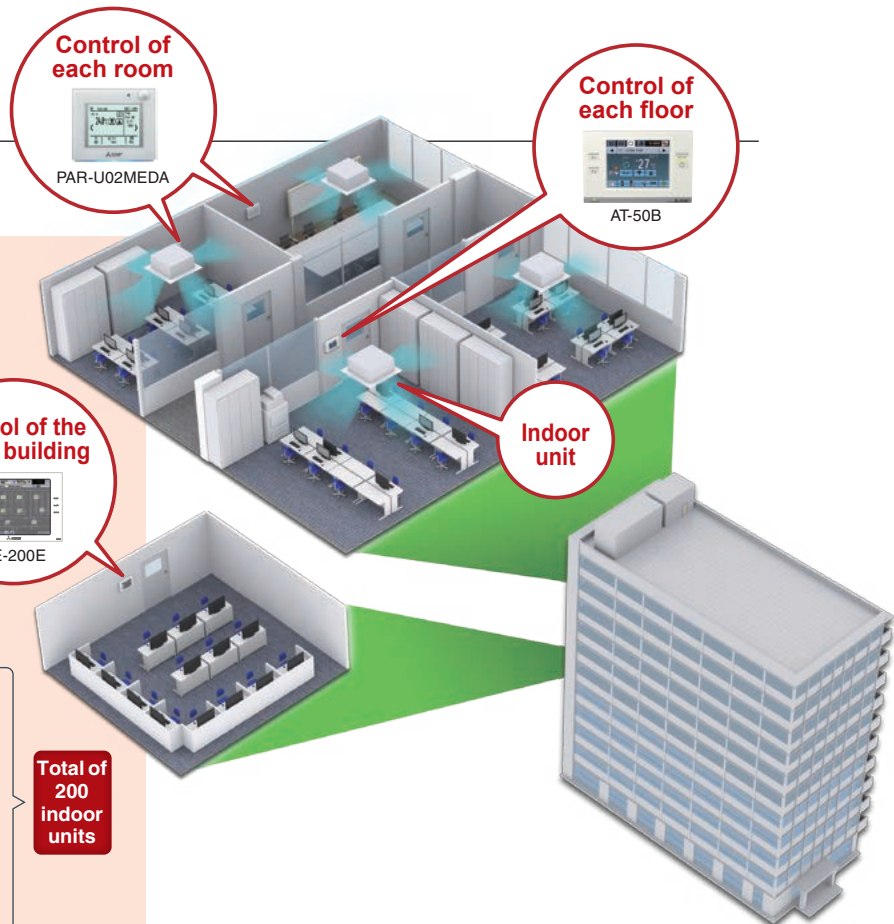
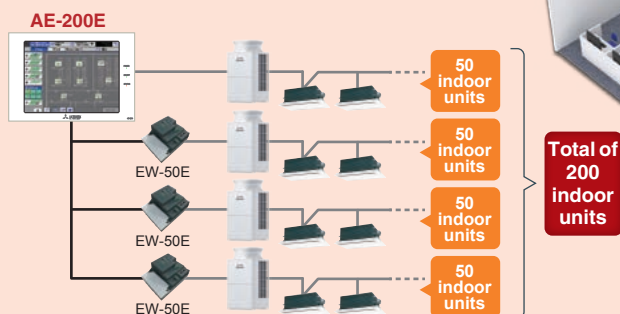



## Controller example

There are many controller options:  
They can be connected to a Building Management System using BACnet® or a LonWorks® interface for a high level of control.

\* Optional parts or licenses may be required depending on the type of control.  
For more detailed information, please contact your nearest sales office or distributor.

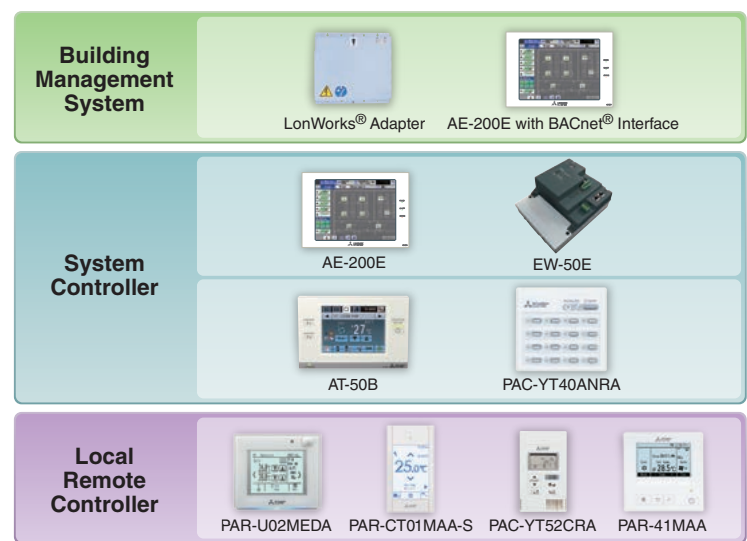

## Examples of controller functions

### Control using smartphone or tablet terminal\* (AE-200E)

Air conditioners can be monitored and operated by using tablets and smartphones when a Wi-Fi router is connected to the LAN.



\* A Wi-Fi router is required to use this function.

### Auto-off function via the occupancy sensor (PAR-U02MEDA)

When the built-in occupancy and brightness sensors detect vacancy in a specific zone, the controller uses its internal function to reduce energy consumption.

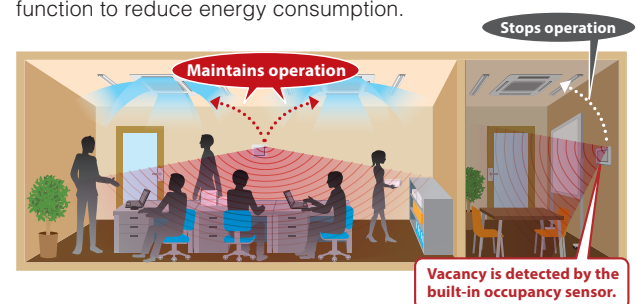

### ME Controller (PAR-U02MEDA)

The ME remote controller can be operated when it is connected with any of the indoor units.  
When changing the room layout, you can set the groups easily with the remote controller.

With ME Remote Controllers:

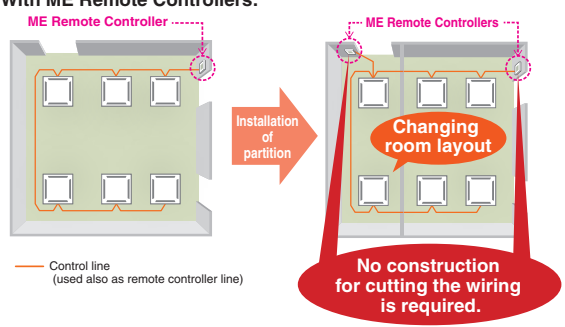

### Operation can be continued even if indoor unit stops for maintenance

Mitsubishi Electric indoor units can continue to operate, even if one is under repair, because the unit's LEV is closed by supplying power from outdoor unit automatically.

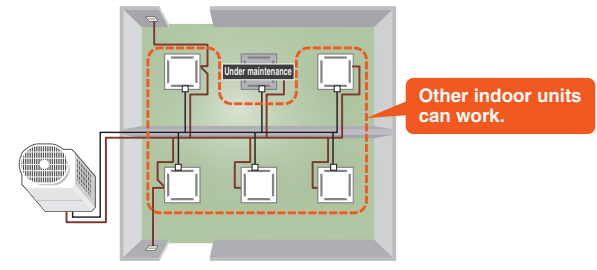

\* Before starting maintenance, please confirm that LEV is closed.

### Schedule-based control of temperature and operation mode

The air conditioner's start time can be scheduled according to the opening time or a fixed time. The function can be locked during working hours so that staff cannot control the air conditioners.

\* Centralized Remote controller is required to use this function.

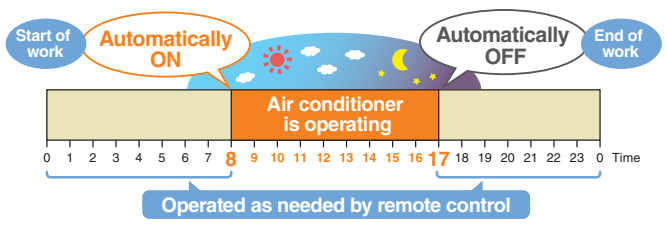

# Advantages of CITY MULTI

## Developed in Japan

Mitsubishi Electric is renowned globally and is a household name with a solid reputation for excellent products and services. The company was founded in 1920 and is known by its present name: Mitsubishi Electric. Since our founding, we have risen to the top level of the air conditioning industry and we continue to maintain that position. The company is proud of its achievements in providing some of awarded systems on the market.

### History of CITY MULTI



**1984** **Japan**  
Launch of the CITY MULTI series of variable refrigerant flow (VRF) air-conditioning systems.

**1992**  
Export of CITY MULTI begins.

**2010** **Overseas**  
YHA, the model for Asia, is released for the first time.



**2014** **Overseas**  
Key parts are improved to create high-performance modules.



**2019** **Overseas**

The latest in the series delivers high energy efficiency. It also ensures excellent reliability with improved cooling capacity at high outside air temperatures.

### Reliable modules appreciated

1991	CITY MULTI R2-Series (awarded "Technical Prize" by Japan Society of Refrigerating and Air Conditioning Engineers)*
2000	City Multi R2 New Refrigerant Series (awarded "Chairman Prize" of ECCJ)*
2007	"Replace Multi Air Conditioner" (awarded "Chairman Prize" by Japan Institute of Invention and Innovation)*
2010	"Replace Multi Air Conditioner" (honored by Minister of Education, Culture, Sports, Science and Technology in the science and technology category)
2011	Ceiling concealed reheat indoor unit "PEFY-AF1200CFM(R)" for North America (awarded "Product of the Year" prize at AHR Expo 2011)
2015	"Grand Multi Air Conditioner 2015" (awarded "Technical Prize" by Japan Society of Refrigerating and Air Conditioning Engineers)*
2017	City Multi Hybrid VRF (awarded "Air Conditioning Product of the Year" prize at The ACR News Awards 2017)

\* The models for Japan were awarded.

## Creating high-quality products with cutting-edge technologies and professional people who have deep experience in the development factory

All models of CITY MULTI to be exported around the world are examined at the development factory to ensure that they can withstand the environmental conditions in each region, and products that have passed the quality check are supplied. The marketing, unit design and quality control departments put together a team to work on developing high-quality products. Also the parts used in the units are checked for quality. We have determined the evaluation criteria for more than 300 parts and use only those that have passed the durability and safety tests.

### Salt spray test

A sodium chloride solution is sprayed on the part to be tested and evaluated, and the rust generated on the surface is observed to evaluate the corrosion resistance.

In accordance with JRA90021, the standard models and BS models are subjected to this salt spray test for 480 hours and 960 hours respectively.



### Heat shock test

The part is exposed to repeated temperature changes to verify its resistance to changes in ambient temperature.



All parts for CITY MULTI have been checked for quality and reliability.

# Mitsubishi Electric Quality

Under its quality first principle, Mitsubishi Electric is creating products with an unwavering commitment to quality, producing air conditioning systems that provide comfortable spaces for people around the world.

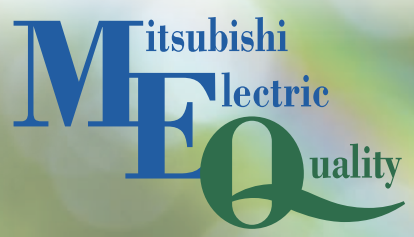

**COMFORT**

Beyond creating a comfortable environment, we aim to achieve harmony between users and their surroundings.

**EFFICIENCY**

We strive to achieve optimum cost performance by continuously reducing energy requirements and improving eco-friendliness.

**DURABILITY**

Our products are subjected to rigorous testing under harsh conditions that are more extreme than that of the real world to ensure years of reliable service.

## Commitment to quality on the production line

The main plant for CITY MULTI, Air-Conditioning & Refrigeration Systems Works, produces many kinds of products and has introduced several unique systems.

These systems include, for example, a “parts server” for preparing parts for assembled, a display for providing indications according to the work point, and “Cart Navi,” which prevents work from proceeding to the next process if the correct procedure and specified tools have not been used to achieve the expected process quality. The plant intends to improve both the production efficiency and quality. As the result of this, human errors can be prevented in operations requiring high skills and when handling small parts, such as screws, thus producing high-quality products. These same systems are used in our Thai plant.



Air-Conditioning & Refrigeration Systems Works



Cart Navi

On the production line for the primary product, i.e. outdoor units, an airtightness check is performed using helium to eliminate any refrigerant leakage from the piping. After the airtightness check is performed twice and the units are assembled, the units are tested to confirm normal operation. Only the units that pass this test are shipped.



Compressor also developed and manufactured by Mitsubishi Electric\* Refrigerant leak inspection process using helium gas

\* Applies to CITY MULTI.



# Advantages of CITY MULTI

## Varied applications

Various commercial and residential facilities can benefit from the advantages of Mitsubishi Electric's CITY MULTI system.

### Design flexibility

Depending on building design, size and usage, the choice of air conditioning differs. The CITY MULTI series offers a wide range of solutions to match various design requirements.

### Energy saving

The CITY MULTI series and system realize high energy savings with zoned comfort operating unit independently by units, room or floors.

### Simple installation

Compared to a conventional chiller and fan coil system, CITY MULTI 2-pipe system does not require pumps or control panels, as these functions are integrated into the outdoor units. Moreover, maintenance is easier with less key components.

## Residence

The CITY MULTI series provides homeowners with large residences with multiple bedrooms an energy efficient solution which realizes comfort living environment through daily operations. Different types of indoor units can be selected and connected to an outdoor unit

### Outdoor unit



Owners

#### Energy saving with zoned comfort

It is possible to manage air conditioning units independently by units, room or floor.

#### High partial load performance

In residential applications, not all rooms are used at once.

Having an efficient operation even at partial load is a great advantage in running cost.

#### Low operation noise

Low noise mode offers residents a peaceful living environment.

\* Capacity drops during low noise mode.



### Condominium

Air-cooled side-flow S series

Small footprint suitable for installation around buildings or even on the balcony.



### Luxury Houses

**Air-cooled heat pump Y series**  
Up to 60HP model lineup and max. 50 indoor units connectable. Suitable to cover multi-story by single outdoor unit.

\* Please do not install the outdoor unit adjacent to a room where quietness is required.

### Flexible installation

External static pressure selectable (0,30,60 Pa) to match site condition.

### Quiet operation mode

Low noise operation contributes to realize a peaceful living environment.  
\* Capacity drops during low noise mode.

(Ex) PUHY-P200YKD Standard 57dB **-13 dB** Low noise mode **44dB**  
Low noise mode (night mode)

## Indoor unit



**Various types of indoor units contribute to meet different room design.**

Owners

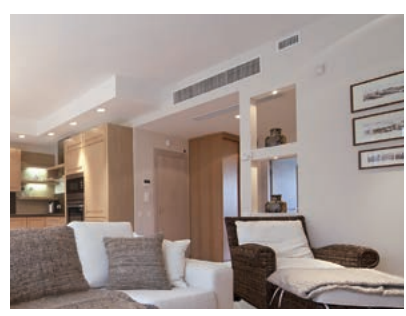
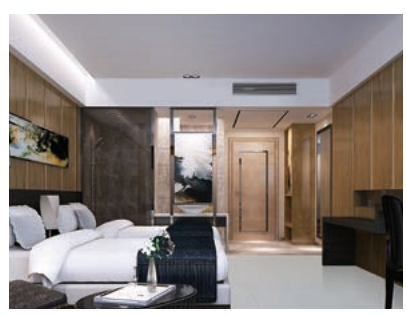

**Low static ceiling concealed type**

Low noise level: Min. 22dB (P15)\*  
External static pressure: 5, 15, 35, 50 Pa



**Medium static ceiling concealed type**

Low noise level : Min.22dB (P20/25)\*  
External static pressure: 35 or 40, 50, 70, 100, 150 Pa

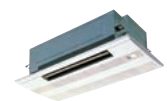

**1-way airflow ceiling mounted type**

Excellent solution for rooms with lighting equipment are at the center of the room or wall surface occupied.

\* Measured in anechoic room under testing condition. Actual noise depends on installation.

## Control

### Local remote controller

**Easy to understand and use with simple buttons.**

Basic operation and status monitoring available.

\* Requires wireless signal receiving unit



Wireless remote controller

### Centralized remote controller

**LCD color touch panel enables easy and simple operation.**

Able to collectively control all indoor units (up to 50 indoor units).



Advanced touch controller

# Advantages of CITY MULTI

## Office

Air conditioning systems supplied by Mitsubishi Electric play an important role in providing comfort to the workers, preserving flexibility, by enabling control to be maintained of the whole building, as well as independent control of floors and spaces.

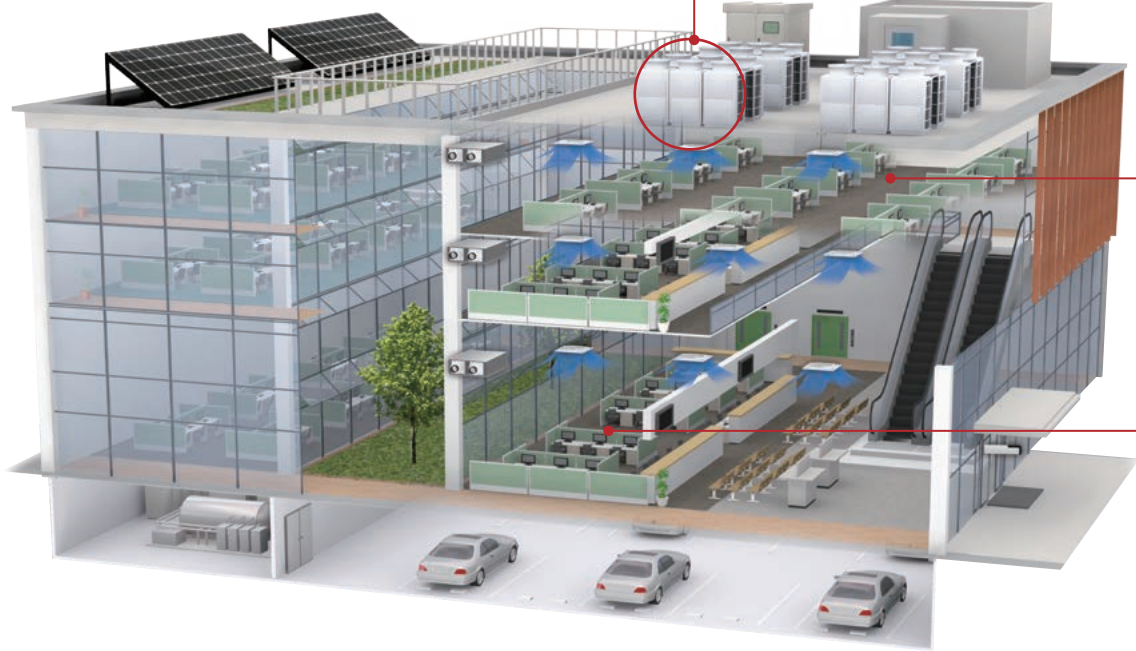

### Outdoor unit / Heat source unit



#### Energy saving with zoned comfort

Owners  
Developers

It is possible to manage air conditioning units independently by units, room or floor. Provides personal comfort for the room occupants and at the same time saves energy.

#### Adaptable to different design and structure

Depending on building structure and design, it is possible to choose the outdoor unit that fits in the available space and are visually discreet.

#### Low rise



##### Air-cooled side-flow S series

Small footprint suitable for installation around buildings or even on the balcony.

#### Middle rise



##### Air-cooled heat pump Y series

One outdoor unit connects up to 50 indoor units. Max total piping length of 1,000m provides flexibility to match requirement of various buildings.

#### High rise



##### Water-cooled heat pump Y series

VRF system with a water circuit. The compact heat source units are installed in machine rooms on each floor suitable for high rise buildings.



#### High reliable system

Owners  
Tenants

Measures in case of malfunction or maintenance leads to higher reliability.

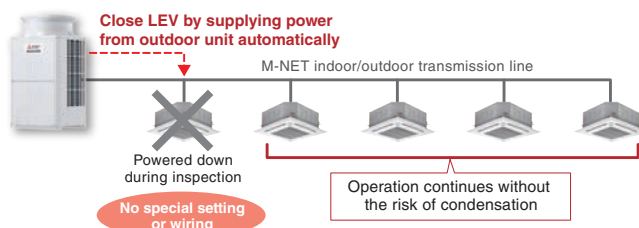

Mitsubishi Electric's original M-NET system enables indoor units to continue operation even when one unit in the system stops due to malfunction or maintenance.



## Centralized Control - AE-200E



### Assist quick response to error

Error notification e-mail and error log / icons on the display enables quick action in case of trouble.

Owners  
Developers

### Time saving billing method

AE-200E apportions the value on the WHM of the outdoor unit based on the operating time of each indoor unit.

### Advanced energy saving with peakcut operation

Energy saving with outdoor unit capacity control depending on demand level or the electric energy values.

### On-site or Remote control

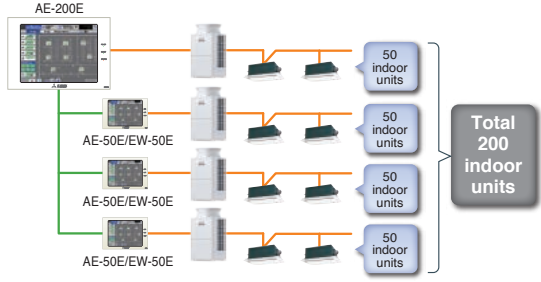

AE-200E is a LCD color touch screen controller monitoring and controlling up to 200 indoor units/groups. Enables on-site status monitoring, operation, scheduling, settings.

### Remote management



The monitoring and control information can also be viewed remotely from a LAN-connected PC, tablet, or smartphones.

## BACnet®

The system can be combined into the large-scaled BMS management via BACnet.

## Meeting rooms

## Local Control

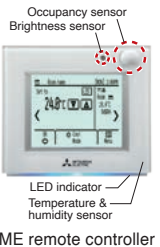

### Energy saving management with automatic OFF

Vacancy detected by the built-in occupancy sensor.



### Easy layout change with ME type controller

Able to smoothly respond to tenant requirement to change layout.

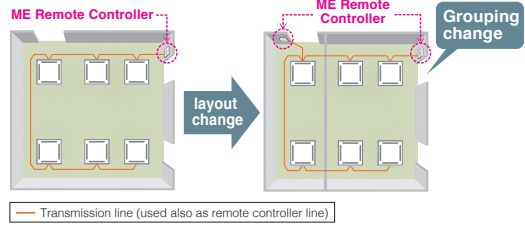

## Open space

## Indoor unit



### Various types of indoor units contribute to enhance air environment.

Tenants

### Customized airflow with i-see sensor

Realized with i-see sensor adjusting 4 vane direction (direct/indirect).

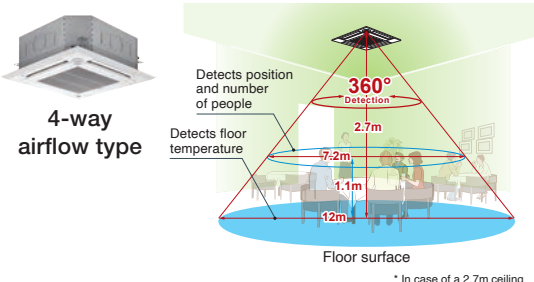

### Visually discreet with flexible duct design

The indoor units are concealed, and only the inlet and outlet slits can be seen. Static pressure up to 150Pa enables ducting to multiple rooms.

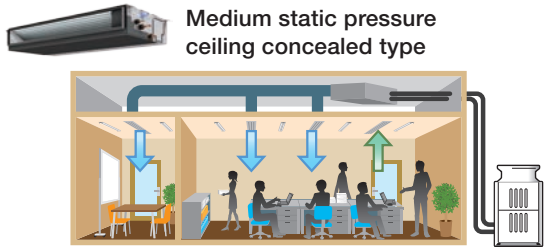

# Advantages of CITY MULTI

## Hotels

The CITY MULTI series provides hotels a solution to realize greater comfort and energy conservation through daily operations.

### Outdoor unit / Heat source unit



#### Energy saving with zoned comfort

It is possible to manage air conditioning units independently by units, room or floor.

Owners  
Developers

#### High partial load performance

In hotels, the occupancy rate depends on the season and day of the week. Having an efficient operation even at partial load is a great advantage in running cost.

#### Adaptable to different design and structure

Depending on building structure and design, it is possible to choose the outdoor unit that fits.

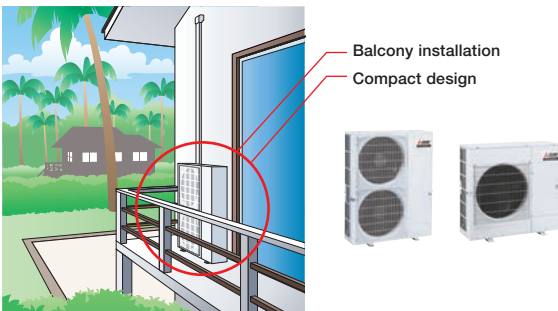

### Villas and Cottages

#### Air-cooled side-flow S series

Small footprint suitable for installation around buildings or even on the balcony.



### Middle-rise Hotels

#### Air-cooled heat pump Y series

One outdoor unit connects up to 50 indoor units. Max total piping length of 1,000m provides flexibility to match requirement of various buildings.

### High-rise Hotels

#### Water-cooled heat pump WY series

VRF system with a water circuit. The compact heat source units are installed in machine rooms on each floor suitable for high rise buildings.



#### High reliable system

Measures in case of malfunction or maintenance leads to higher reliability.

Owners  
Tenants

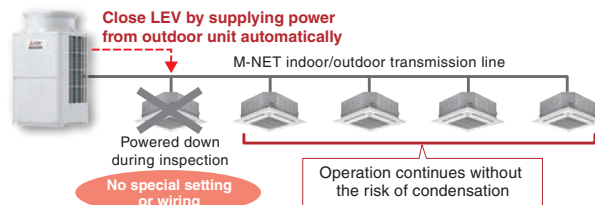

# Centralized Control - AE-200E



## System management and control with AE-200E

Owners

### On-site or Remote control

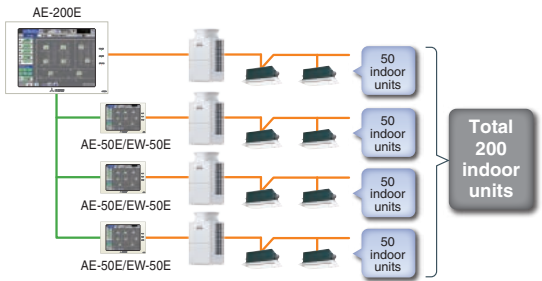

AE-200E is a LCD color touch screen controller monitoring and controlling up to 200 indoor units/groups. Enables on-site status monitoring, operation, scheduling, settings.

### Remote management



Remote control/monitoring from a LAN-connected PC, tablet, or smartphone.  
\* A Wi-Fi router is required.

## BACnet®

The system can be combined into the large-scaled BMS management via BACnet.



## Prevent unnecessary operation of the indoor unit.

Owners

Change temperature setting when window or door to the balcony opens/closes.

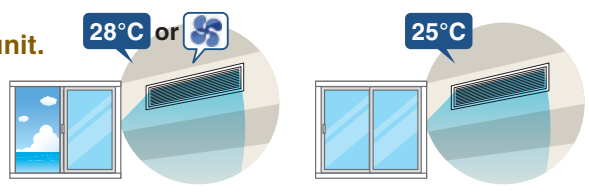

## Prioritize guest comfort at all times

Guests

### Pre-cooling/pre-heating the room

By using the centralized controller's schedule function, it is possible to pre-cool/pre-heat the room before the guest arrives.

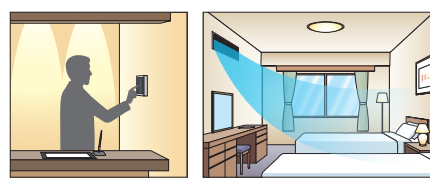

### Interlock functions to ensure comfort

By interlocking an in-house power generator and AE-200E, in the case of a power shutdown, it is possible to reduce operating capacity in common areas such as the lobby or staff room.

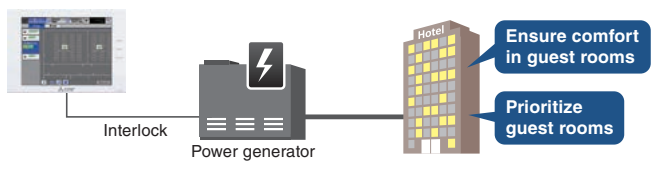

## Local Control



## Easy to use with large-sized icons and full color touch panel display.

Guests

Customized display color and control parameters.



MA touch remote controller

## Indoor unit



## Ceiling concealed low-noise type

Guests

Blends in various designed room and provide quiet sleeping atmosphere with low operation noise.

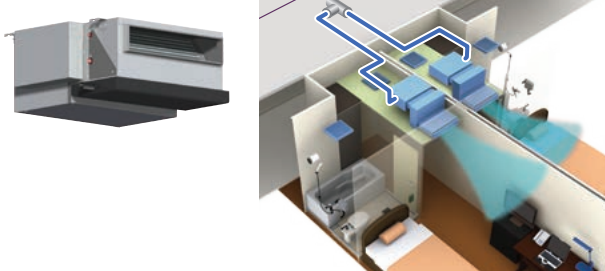



# Advantages of CITY MULTI

## Schools

CITY MULTI series offer energy saving optimal air environment mandatory for students to concentrate and learn better.

### Outdoor unit



#### Energy saving with zoned comfort

It is possible to manage air conditioning units independently by units, room or floor.



#### High partial load performance

In schools, not all rooms are used at once. Having an efficient operation even at partial load is a great advantage in running cost.

### Small size

#### The air-cooled side-flow S series

Small footprint suitable for low-rise school buildings where the buildings are separated by functions such as classrooms, libraries or even by grades.

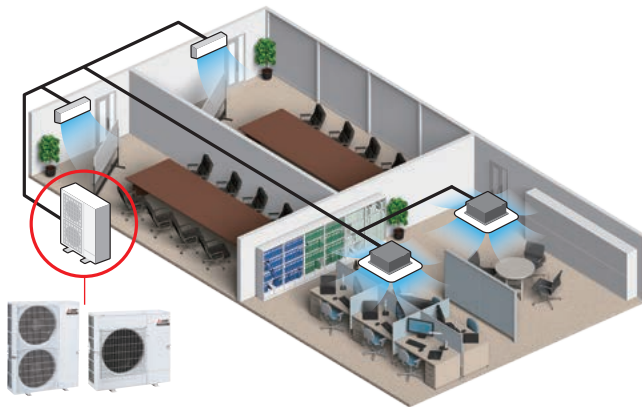

### Middle - Large size

#### The air-cooled heat pump Y series

One outdoor unit connecting up to 50 indoor units. The unit can be installed collectively either on the roof or on the ground level depending on requirement.

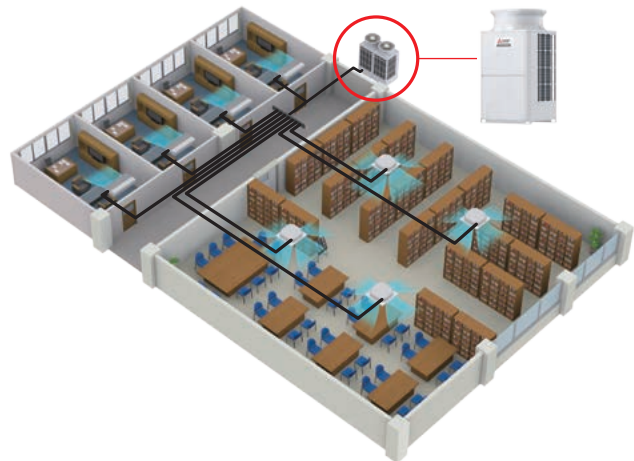

### Local Control



MA remote controller



#### Easy to use with basic controls

##### Schedule setting

Weekly schedule timer available. Different schedule can be set per day of week and 8 operation patterns (ON/OFF, Set temp)

##### Prevent unnecessary operation

To limit the access of operation such as students, it is possible to prohibit operations such as, ON/OFF, Mode, Set temp, Menu, Fan, Louver, Vane.

### Indoor unit



#### Wide selection to match design requirement

##### Floor standing exposed types

Offers wide range of airflow rate and static pressure options. Suitable for wide open areas such as the cafeteria and sports halls.

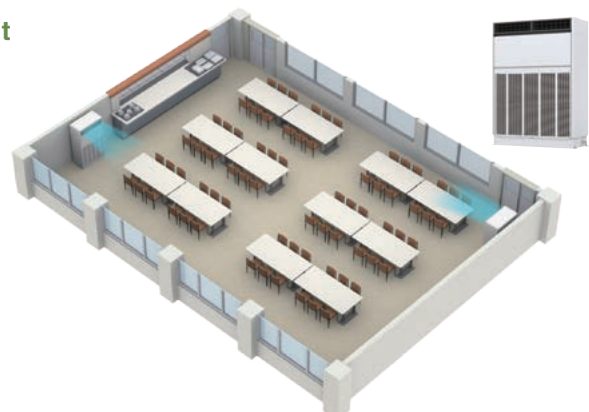
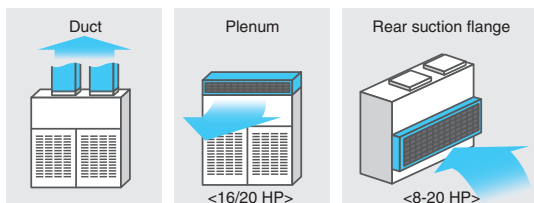

# Hospitals

CITY MULTI series are energy efficient playing an important role to maintain comfortable air environment for the patients spending quality time in the facility and doctors and staff working long hours.

## Outdoor unit

**Energy saving with zoned comfort**  
It is possible to manage air conditioning units independently by units, room or floor.

**High reliable operation modes**

**Rotation control**  
Longer service life by operating outdoor units alternately and reducing operating load.

**Emergency operation mode**  
Outdoor unit temporary performs emergency operation if there is at least one module that can operate normally.

\* There is a limit to the time that can be continued emergency operation.

**Wide operation range**  
High operating capacity even at 52°C outside temperature.

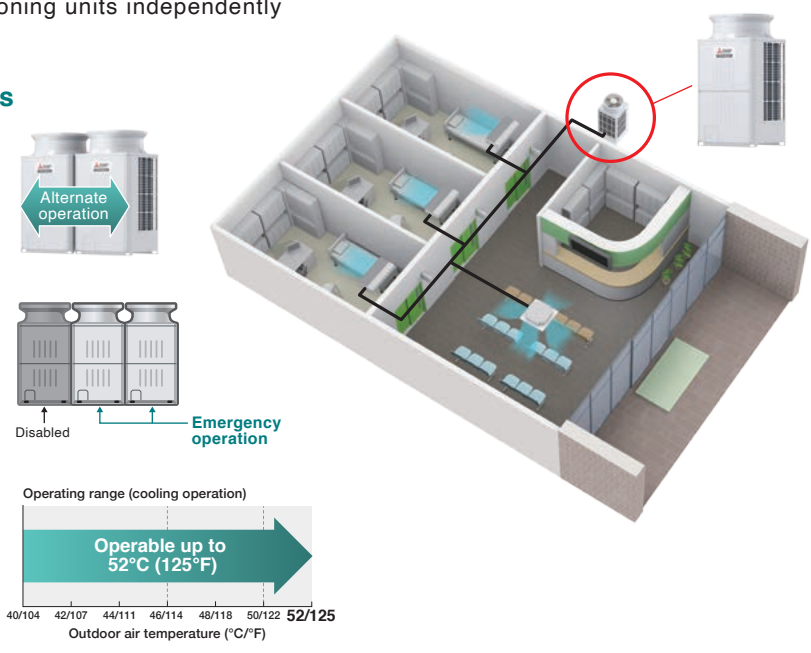

## Fresh air

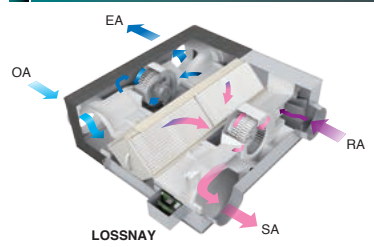

**Optimized air quality with fresh air**  
Ventilation plays an important role to provide patients and doctors with adequate air quality throughout the day. LOSSNAY system recovers the energy within the stale air from the inside and used to pre-cool the incoming fresh air from outside.

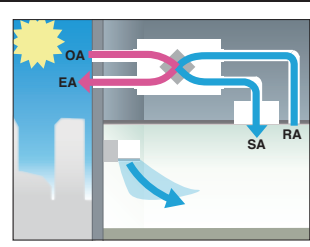

## Control

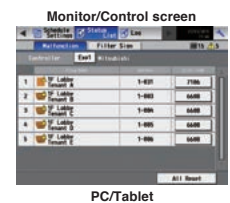
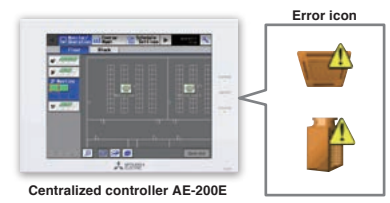

**Assist quick response to error**  
Error notification e-mail and error log / icons on the display enables quick action in case of trouble.

## Indoor unit

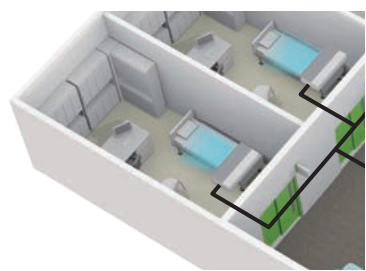

**Comfort air distribution with low noise level**

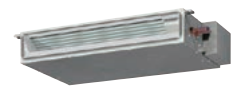

**Low static ceiling concealed type**  
Sound pressure level: Min. 22dB (P15)\*  
External static pressure: 5, 15, 35, 50 Pa



**Medium static ceiling concealed type**  
Sound pressure level: Min.22dB (P20/25)\*  
External static pressure: 35 or 40, 50, 70, 100, 150 Pa

\* Measured in anechoic room under testing condition. Actual noise depends on installation.

# Outdoor/Heat source unit





# Outdoor unit

\* For the restrictions on piping, please refer to the DATABOOK.

## Side flow type

- The side flow type, which has the selection from 4 HP up to 12 HP, contributes to reduction in installation space.
- 1 fan models are more compact, 981 mm [38-5/8 in.] in height



**NEW**  
Cooling only  
(4-12HP)

- PUMY-CP VKM2
- PUMY-CP YKM2
- PUMY-CP YBM2

**NEW**  
Heat pump  
(4-12HP)

- PUMY-SP V(Y)KM2
- PUMY-P YKM3
- PUMY-P YBM2

## Top flow type

- A wide lineup of up to 60 HP
- Total piping length of 1000 m [3281 ft.], height difference of 50 m [164 ft.], and high flexibility in piping work
- Features various operation modes, and the unit can be set according to the intended use
- Both standard and high-efficiency models are available



**Cooling only**  
(8-60HP)

- PUCY-(E)P Y(S)KD



**Heat pump**  
(8-60HP)

- PUHY-(E)P Y(S)KD

## Heat source unit







- Use of water piping allows for individual air conditioning with no need to worry about height differences.
- Installation of heat source units in machine rooms help reduce influence on building exteriors.



**Heat pump**  
(8-36HP)

- PQHY-P YLM-A1

# Wide selection of outdoor units

System	Series	Type	Model name	HP											
				Model	4	5	5.5	7	8	9	10	12	14	16	
				P100	P125	P140	P175	P200	P225	P250	P300	P350	P400		
Air cooled	S	Cooling only	<b>S-Series</b> <b>NEW</b> PUMY-CP VKM2 (-BS) PUMY-CP YKM2 (-BS) PUMY-CP YBM2 (-BS) CP100-CP140  Page 27-Page 29		VKM2 YKM2 4	5 5	5.5		YKM2 7	8 8	9 9	YBM2 10 12			
		Heat Pump	<b>S-Series</b> <b>NEW</b> PUMY-SP VKM2 (-BS) PUMY-SP YKM2 (-BS) Page 30-Page 31		4	5	5.5								
		Heat Pump	<b>S-Series</b> <b>NEW</b> PUMY-P YKM3(-BS) PUMY-P YBM2(-BS) P175-P225  Page 32-Page 33						YKM3 7	8 8	9 9	YBM2 10 12			
Air cooled	Y	Cooling only	<b>Y-Series</b> PUCY-P YKD(-BS) PUCY-P YSKD(-BS)  Page 55-Page 64	S					8			10 12			
			L										14	16	
			XL												
		Y-Series - High Efficiency	<b>Y-Series - High Efficiency</b> PUCY-EP YSKD(-BS)  Page 65-Page 70	S											8 8
		L													
		XL													
Water cooled	Y	Heat Pump	<b>Y-Series</b> PUHY-P YKD(-BS) PUHY-P YSKD(-BS)  Page 71-Page 80	S					8			10 12			
			L										14	16	
			XL												
		Y-Series - High Efficiency	<b>Y-Series - High Efficiency</b> PUHY-EP YSKD(-BS)  Page 81-Page 85	S											8 8
		L													
		XL													
Water cooled	Y	Heat Pump	<b>WY-Series</b> PQHY-P YLM-A1 PQHY-P YSLM-A1  Page 91-Page 97	S					8			10 12			
			L										14	16	
			S												8 8
			L												

\* The circled numbers in the table indicate horse power, and the combination of S, L, and XL modules.





# S-series

## PUMY

The line-up of side-flow type outdoor units includes models from 4 HP to 12 HP, which offers flexibility in installations in tight spaces. This type is suitable for small-scale offices and residences. 1-phase type (VKM) and 3-phase type (YKM/YBM) are available.



### Heat pump NEW

- PUMY-SP VKM2
- PUMY-SP YKM2
- PUMY-P YKM3
- PUMY-P YBM2

### Cooling only NEW

- PUMY-CP VKM2
- PUMY-CP YKM2
- PUMY-CP YBM2

### Installation image

#### Residence

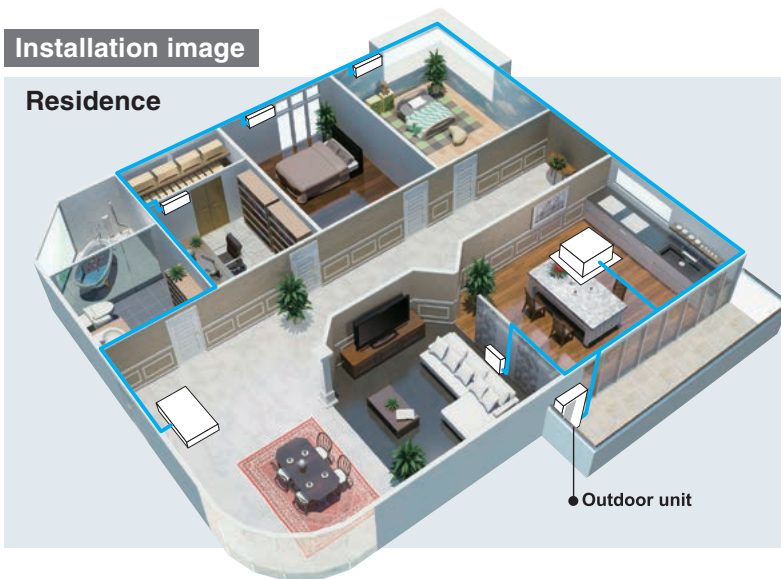

### Advantage of PUMY (for residences)

One outdoor unit (10 HP-12 HP) can be connected up to 29 indoor units (P15-250). Even when indoor units are installed in many rooms, one outdoor unit can connect multiple indoor units.



**Space savings**

### Wide selection from 4 HP up to 12 HP

Model	100	125	140	175	200	225	250	300
Heat pump	SP100-140V(Y)KM2			P175-225YKM3				P250-300YBM2
Cooling only	CP100-140V(Y)KM2			CP175-225YKM2				CP250-300YBM2

10-12 HP (P250-P300) is available!

#### Heat pump



SP100-140

P175-225

P250-300

#### Cooling only



CP100-140

CP175-225

CP250-300

## Features

### ① Operation guaranteed at an outside air temperature of up to 52°C [125°F].

- New inverter technology has made it possible for units to operate at an outdoor air temperature as high as 52°C [125°F].

### ② Quiet mode

All models have three quiet modes in addition to the normal mode, and a suitable noise mode can be selected from among the four available modes. The noise level can be set according to the application, for example, in a residential zone where noise may be an issue.

- \* Capacity reduction differs by mode setting.
- \* PAC-SC36NA-E is required to activate this mode.
- \* Available during cooling only.

■ Operation at high temperatures (52°C/125°F)  
Operating range (cooling operation)

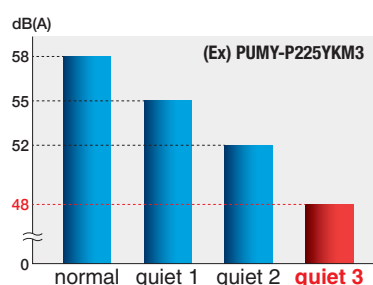
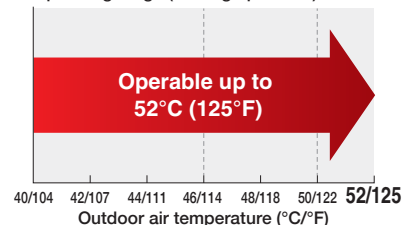

## Piping length

[CP100-140Y/VKM2]  
[SP100-140Y/VKM2]

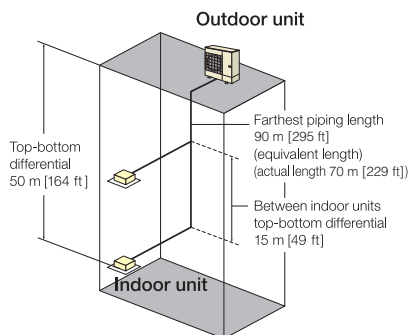

Refrigerant Piping Lengths	Maximum meters [feet]
Total length	120 [393]
Maximum allowable length	70 (90 equivalent) [229 (295)]
Farthest indoor from first branch	50 [164]*1

Vertical differentials between units	Maximum meters [feet]
Indoor/outdoor (outdoor higher)	50 [164]
Indoor/outdoor (outdoor lower)	30 [98]
Indoor/indoor	15 [49]

[CP175-225YKM2]  
[P175-225YKM3]

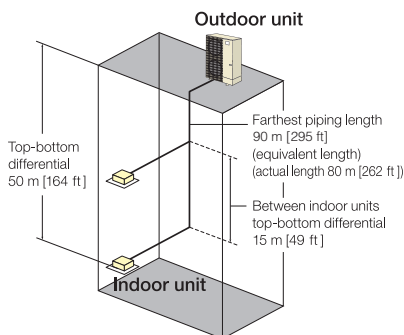

Refrigerant Piping Lengths	Maximum meters [feet]
Total length	150 [492]
Maximum allowable length	80 (90 equivalent) [262 (295)]
Farthest indoor from first branch	30 [98]

Vertical differentials between units	Maximum meters [feet]
Indoor/outdoor (outdoor higher)	50 [164]
Indoor/outdoor (outdoor lower)	40 [131]
Indoor/indoor	15 [49]

[CP250-300YBM2]  
[P250-300YBM2]

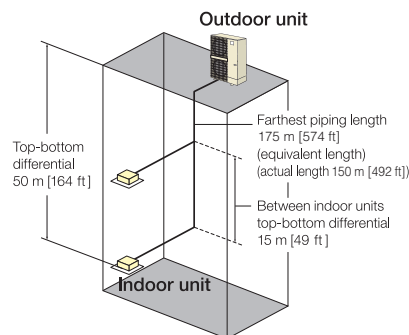

Refrigerant Piping Lengths	Maximum meters [feet]
Total length	310 [1,017]
Maximum allowable length	150 (175 equivalent) [492 (574)]
Farthest indoor from first branch	30 [98]

  

Vertical differentials between units	Maximum meters [feet]
Indoor/outdoor (outdoor higher)	50 [164]
Indoor/outdoor (outdoor lower)	40 [131]
Indoor/indoor	15 [49]

\*1 Use liquid pipe of ø9.52 for less than P50 indoor units, when farthest length from the first branch exceeds 30m.

# Features of the Branch Box

Connecting branch boxes makes it possible to connect to Mitsubishi Electric indoor units (room air conditioners, Mr. SLIM) that do not normally support M-NET connections.

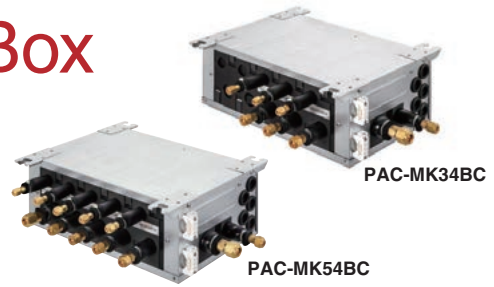

## System example

The use of branch boxes makes it possible for PUMY-Series devices to connect not only to CITY MULTI indoor units but also to Mitsubishi Electric indoor units that do not normally support M-NET connections. Thus it is possible to connect to room air conditioners and Mr. SLIM indoor units, allowing for a selection specifically designed to suit how the room is being used.

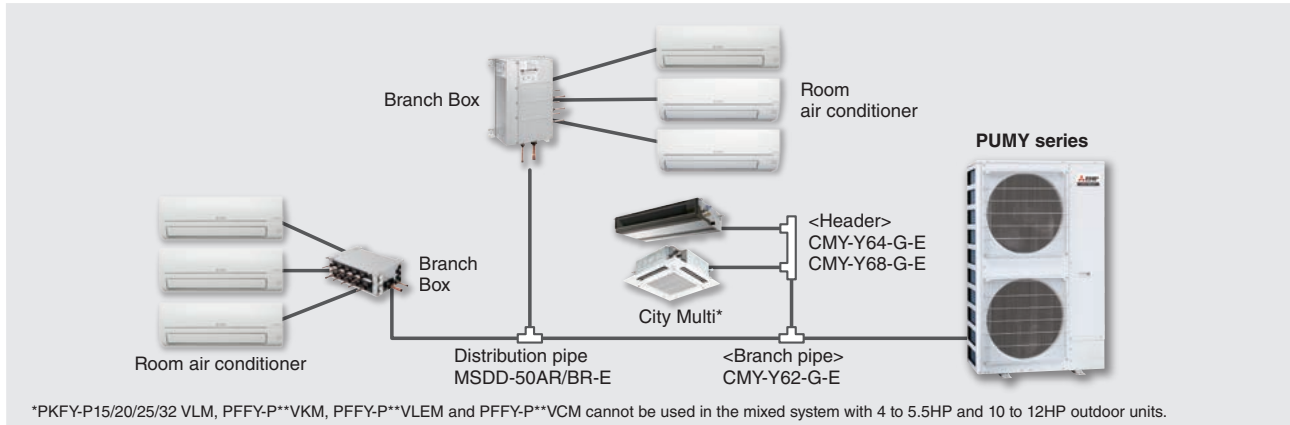

## Specifications

Model			PAC-MK54BC	PAC-MK34BC
Connectable Number of Indoor Units			Max. 5	Max. 3
Power Supply			Outdoor power supply, Branch Box / Outdoor separate power supply	
Source			1-phase, 220/230/240V, 50Hz, 1-phase, 220/230V, 60Hz	
Outdoor (V/Phase/Hz)				
Total Input		kW	0.003	
Operating Current		A	0.05	
Dimensions H x W x D		mm	170 × 450 × 280	
Weight		kg	7.4	6.7
Piping (diameter)	Branch (Indoor Side)	Liquid	6.35 × 5	6.35 × 3
		Gas	9.52 × 4, 12.7 × 1	9.52 × 3
	Main (Outdoor Side)	Liquid		9.52
		Gas		15.88
Connection Method			Flared	
Wiring	to Indoor Unit		3-wire + Earth wire	
	to Outdoor Unit		3-wire + Earth wire	

## Installation image

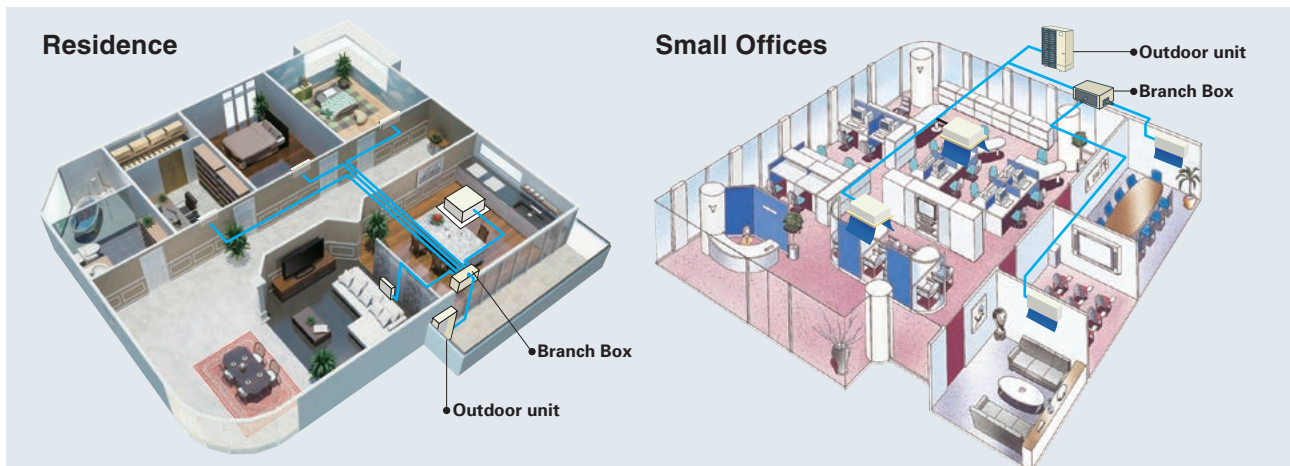

Consolidating heat sources for room air conditioners, which require a 1:1 connection between the outdoor unit and indoor unit, and reducing installation space is possible.

Because the branch box can be installed indoors or outdoors and mounted on a wall, ceiling, or floor, it is possible to meet the requirements of various installation situations flexibly.

\*Please refer to installation manual for installation restrictions.



## Precautions for unit construction

- The capacity and number of indoor units when using a branch box differs from situations when no branch box is used. Refer to the installation manual for the each outdoor unit for more information. Moreover, the indoor unit lineup varies from country to country, so contact your local distributor for details.
- Capacity calculations for the entire system will depend on the connected indoor unit. Refer to the installation manual for more information.
- Piping lengths also differ when using a branch box. Refer to the installation manual for the each outdoor unit for more information.

## Comparison of Piping Lengths for PUMY-Series Models

		Maximum Meter					
		Only City Multi *1 Indoor Unit	Only Branch Box Connection	Mixed System (City Multi *1 Indoor Unit + Branch Box)			
				City Multi *1 Indoor Unit	Via Branch Box		
P250/300 CP250/300	Refrigerant Piping Length	Total Length	310	240	310		
		Maximum Allowable Length	150 (175 equivalent) *2	80 *2	85 (95 equivalent) *2		
		Farthest Indoor From First Branch	30	30 *3	30	30 *3	
	Vertical Differentials Between Units	Indoor/Outdoor(Outdoor higher)	50	50	50		
		Indoor/Outdoor(Outdoor Lower)	40	40	40		
		Indoor/Indoor	15	12	15 *4		
	Refrigerant Piping Length	Total branch pipe length	—	145	—	145	
		Farthest branch pipe length	—	25	—	25	
		Total main pipe length	—	95	—	95	
		Farthest main pipe length	—	—	—	—	
	Vertical Differentials Between Units	Branch box/Indoor	—	15	—	15	
		Branch box/Branch box	—	15	—	15	
	P175/200/225 CP175/200/225	Refrigerant Piping Length	Total Length	150	150	150	
			Maximum Allowable Length	80 (90 equivalent) *5	80 *5	80 (90 equivalent) *5	
Farthest Indoor From First Branch			30	30 *3	30	30 *3	
Vertical Differentials Between Units		Indoor/Outdoor(Outdoor higher)	50	50	50		
		Indoor/Outdoor(Outdoor Lower)	40	40	40		
		Indoor/Indoor	15	15 *4	15 *4		
Refrigerant Piping Length		Total branch pipe length	—	95	—	95	
		Farthest branch pipe length	—	25	—	25	
		Total main pipe length	—	55	—	55	
		Farthest main pipe length	—	55 *5	—	55 *5	
Vertical Differentials Between Units		Branch box/Indoor	—	15	—	15	
		Branch box/Branch box	—	15	—	15	
SP 100/125/140 CP100/125/140		Refrigerant Piping Length	Total Length	120	120	120	
			Maximum Allowable Length	70 (90 equivalent)	80	70 (90 equivalent)	
	Farthest Indoor From First Branch		50 *6	50 *3	50 *6	50 *3 *6	
	Vertical Differentials Between Units	Indoor/Outdoor(Outdoor higher)	50	50	50		
		Indoor/Outdoor(Outdoor Lower)	30	30	30		
		Indoor/Indoor	15	15 *4	15 *4		
	Refrigerant Piping Length	Total branch pipe length	—	95	—	95	
		Farthest branch pipe length	—	25	—	25	
		Total main pipe length	—	55	—	55	
		Farthest main pipe length	—	55	—	55	
	Vertical Differentials Between Units	Branch box/Indoor	—	15	—	15	
		Branch box/Branch box	—	15	—	15	

\*1 Include system with connection kit

\*2 Liquid pipe diameter: 12.7 mm, in case of further piping length is longer than 90 m, or connect with PEFY-P200/250.

\*3 Farthest branch box from first branch.

\*4 In case of branch box connection : 12m

\*5 Liquid pipe diameter: 12.7 mm, in case of further piping length is longer than 60 m, or the farthest length of main pipe between outdoor unit and branch box is longer than 20 m in branch box system.

\*6 Use liquid pipe of  $\phi 9.52$  for less than P50 indoor units, when farthest length from the first branch exceeds 30m.

## Optional Parts for Branch Boxes

Description	Model	Remarks
Joint pipe	MAC-A454JP-E	For $\phi 9.52 \rightarrow \phi 12.7$
	PAC-SG76RJ-E	For $\phi 9.52 \rightarrow \phi 15.88$
	PAC-493PI	For $\phi 6.35 \rightarrow \phi 9.52$
	MAC-A456JP-E	For $\phi 12.7 \rightarrow \phi 15.88$
	MAC-A455JP-E	For $\phi 12.7 \rightarrow \phi 9.52$
	PAC-SG71RJ-E	For $\phi 15.88 \rightarrow \phi 22.2$
	PAC-SG77RJ-E	For $\phi 15.88 \rightarrow \phi 25.4$
Port connector	PAC-SG75RJ-E	For $\phi 15.88 \rightarrow \phi 19.05$
2-Branch pipe	Braze	MSDD-50BR-E
	Flare	MSDD-50AR-E
Branch box outer cover	PAC-AK350CVR-E	
Filter dryer for liquid pipe	PAC-SG82DR-E	For $\phi 9.52$

OUTDOOR UNIT

**S-series**

PUMY-CP VKM2 (-BS) **NEW**



**Specifications**

Model	PUMY-CP100VKM2 (-BS)	PUMY-CP125VKM2 (-BS)	PUMY-CP140VKM2 (-BS)
Power source	1-phase 220-230-240 V, 50 Hz; 1-phase 220 V, 60 Hz		
Cooling capacity (Nominal)	*1 kW 11.2	14.0	15.5
	*1 BTU/h 38,200	47,800	52,900
	Power input kW 2.80	3.84	4.70
	Current input A 12.99-12.42-11.90, 12.99	17.81-17.04-16.33, 17.81	21.80-20.85-19.98, 21.80
	EER kW/kW 4.00	3.65	3.30
Temp. range of cooling	Indoor temp. W.B. Outdoor temp. D.B.	15 to 24°C (59 to 75°F) 10 to 52°C (50 to 126°F)	
Indoor unit connectable	Total capacity Model/Quantity CITY MULTI	50 to 150% of outdoor unit capacity *2	
		15-125/7	15-140/10
Sound pressure level (measured in anechoic room)	*3 dB <A>	52/-	53/-
Refrigerant piping diameter	Liquid pipe mm (in.) Gas pipe mm (in.)	9.52 (3/8) Flared 15.88 (5/8) Flared	
Fan	Type x Quantity Air flow rate m <sup>3</sup> /min L/s cfm	Propeller Fan × 1 78.8 1,313 2,782	
	*4 Motor output kW	0.20 × 1	
Compressor	Type x Quantity Starting method Motor output kW	Twin rotary hermetic compressor × 1 Inverter 2.8	
		3.4	3.6
External finish	Galvanized Steel Sheet Munsell No. 3Y 7.8/1.1		
External dimension H x W x D	mm in.	981 × 1050 × 330 (+25) 38-5/8 × 41-3/8 × 13 (+1)	
Protection devices	High pressure protection Inverter circuit (COMP./FAN) Compressor Fan motor	High pressure switch Overcurrent detection, Overheat detection (Heat Sink thermistor) Compressor thermistor, Overcurrent detection, Compressor protector Overheating, Voltage protection	
Refrigerant	Type x original charge	R410A 2.9kg	
Net weight	kg (lbs)	86 (190) *5	
Heat exchanger	Micro Slit Fin and Copper tube		
Defrosting method	—		
Optional parts	Joint: CMY-Y62-G-E, Header: CMY-Y64/68-G-E		

**Notes:**

\*1 Nominal conditions

	Indoor	Outdoor	Pipe length	Level difference
Cooling	27°C DB/19°C WB (81°F DB/66°F WB)	35°C DB (95°F DB)	7.5m (24-9/16ft.)	0m (0ft.)

\*2 Up to 150% can be connected. However, up to 130% for simultaneous operation.

\*3 Cooling mode/Heating mode

\*4 External static pressure option is available (30Pa/3.1mmH<sub>2</sub>O).

\*5 87 (192), for PUMY-CP100/125/140VKM2-BS.

\*Nominal conditions \*1 are subject to ISO 15042.

\*Due to continuing improvement, above specification may be subject to change without notice.

OUTDOOR UNIT

S-series

PUMY-CP YKM2 (-BS) **NEW**

CP100-140

CP175-225

## Specifications

Model	PUMY-CP100YKM2 (-BS)	PUMY-CP125YKM2 (-BS)	PUMY-CP140YKM2 (-BS)	PUMY-CP175YKM2 (-BS)	PUMY-CP200YKM2 (-BS)	PUMY-CP225YKM2 (-BS)		
Power source	3-phase 380-400-415 V, 50 Hz; 3-phase 380 V, 60 Hz							
Cooling capacity (Nominal)	*1 kW	11.2	14.0	15.5	20.0	22.4	25.0	
	*1 BTU/h	38,200	47,800	52,900	68,200	76,400	85,300	
	Power input kW	2.80	3.84	4.70	5.00	5.74	6.54	
	Current input A	4.48-4.25-4.10, 4.48	6.14-5.83-5.62, 6.14	7.52-7.14-6.88, 7.52	8.94-8.50-8.19, 8.94	10.03-9.53-9.18, 10.03	11.17-10.61-10.23, 11.17	
EER	kW/kW	4.00	3.65	3.30	4.00	3.90	3.82	
Temp. range of cooling	Indoor temp.	W.B. 15.0 to 24.0°C (59 to 75°F)						
	Outdoor temp.	D.B. 10 to 52.0°C (50 to 126°F)						
Indoor unit connectable	Total capacity	50 to 150% of outdoor unit capacity *2						
	Model/Quantity	CITY MULTI	15-125/7	15-140/10	15-140/12	15-200/12	15-250/12	15-250/12
Sound pressure level (measured in anechoic room)	*3 dB <A>	52/-	53/-	54/-	57/-	57/-	58/-	
Refrigerant piping diameter	Liquid pipe	mm (in.) 9.52 (3/8) Flared			9.52 (3/8) Flared*4			
	Gas pipe	mm (in.) 15.88 (5/8) Flared			22.2 (7/8) Brazed			
Fan	Type x Quantity	Propeller Fan x 1			Propeller Fan x 2			
	Air flow rate	m <sup>3</sup> /min	78.8			134	134	143.8
		L/s	1,313			2,233	2,233	2,397
		cfm	2,782			4,732	4,732	5,078
*5 Motor output	kW	0.20 x 1			0.20 + 0.20			
Compressor	Type x Quantity	Twin rotary hermetic compressor x 1			Scroll hermetic compressor x 1			
	Starting method	Inverter						
	Motor output	kW	2.6	3.5	3.7	3.5	3.9	4.3
External finish	Galvanized Steel Sheet Munsell No. 3Y 7.8/1.1							
External dimension H x W x D	mm	981 x 1050 x 330 (+25)			1,338 x 1,050 x 330 (+25)			
	in.	38-5/8 x 41-3/8 x 13 (+1)			52-11/16 x 41-11/32 x 13 (+1)			
Protection devices	High pressure protection	High pressure switch						
	Inverter circuit (COMP./FAN)	Overcurrent detection, Overheat detection (Heat Sink thermistor)						
	Compressor	Compressor thermistor, Overcurrent detection, Compressor protector						
	Fan motor	Overheating, Voltage protection						
Refrigerant	Type x original charge	R410A 2.9kg			R410A 6.3kg			
Net weight	kg (lbs)	87 (191) *6			129 (285) *6			
Heat exchanger	Micro Slit Fin and Copper tube			Cross Fin and Copper tube				
Defrosting method	—			Reversed refrigerant circuit				
Optional parts	Joint: CMY-Y62-G-E, Header: CMY-Y64/68-G-E							

## Notes:

\*1 Nominal conditions

	Indoor	Outdoor	Pipe length	Level difference
Cooling	27°C DB/19°C WB (81°F DB/66°F WB)	35°C DB (95°F DB)	7.5m (24-9/16ft.)	0m (0ft.)

\*2 Up to 150% can be connected. However, up to 130% for simultaneous operation.

\*3 Cooling mode/Heating mode

\*4 Liquid pipe diameter: 12.7mm in case that the farthest piping length is longer than 60m, or piping length from outdoor unit to a branch box is longer than 20m.

\*5 External static pressure option for CP100/125/140 is available (30 Pa/3.1 mmH<sub>2</sub>O).

\*6 88 (195), for PUMY-CP100/125/140YKM2-BS. 130 (287) for PUMY-CP175/200/225YKM2-BS.

\*Nominal conditions \*1 are subject to ISO 15042.

\*Due to continuing improvement, above specification may be subject to change without notice.



OUTDOOR UNIT

S-series

PUMY-CP YBM2 (-BS) **NEW**

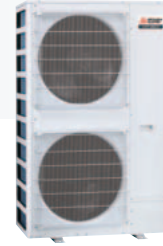

Specifications

Model		PUMY-CP250YBM2 (-BS)	PUMY-CP300YBM2 (-BS)
Power source		3-phase 380-400-415 V, 50 Hz; 3-phase 380 V, 60 Hz	
Cooling capacity (Nominal)	*1 kW	28.0	33.5
	*1 BTU/h	95,500	114,300
Power input	kW	7.18	8.59
	A	11.73-11.14-10.74, 11.73	14.03-13.33-12.85, 14.03
	kW/kW	3.90	3.90
Temp. range of cooling	Indoor temp. W.B.	15.0 to 24.0°C (59 to 75°F)	
	Outdoor temp. D.B.	10.0 to 52.0°C (50 to 126°F)	
Indoor unit connectable	Total capacity	50 to 150% of outdoor unit capacity *2	
	Model/Quantity	CITY MULTI 15-250/24	15-250/29
Sound pressure level (measured in anechoic room)	dB <A>	59	60
Refrigerant piping diameter	Liquid pipe mm (in.)	9.52(3/8) Flared *5	12.7(1/2) Flared
	Gas pipe mm (in.)	22.2(7/8) Brazed	25.4(1) Brazed
Fan	Type x Quantity	Propeller Fan x 2	
	Air flow rate	m <sup>3</sup> /min	178
		L/s	2,966
		cfm	6,285
Motor output kW	0.375 + 0.375		
Compressor *3	Type x Quantity	Scroll hermetic compressor x 1	
	Starting method	Inverter	
	Motor output kW	6.77	7.59
External finish		Galvanized Steel Sheet Munsell No. 3Y 7.8/1.1	
External dimension H x W x D	mm	1,662 x 1,050 x 460 (+45)	
	in.	65-7/16 x 41-11/32 x 18-7/64 (+1-49/64)	
Protection devices	High pressure protection	High pressure switch	
	Inverter circuit	Overcurrent detection, Overheat detection (Heat Sink thermistor)	
	Compressor	Compressor thermistor, Overcurrent detection, Compressor protector	
	Fan motor	Overcurrent, Overheating, Voltage protection	
Refrigerant	Type x original charge	R410A 8.0kg	
Net weight	kg (lbs)	185 (408) *4	
Heat exchanger		Micro-Slit Fin and Copper tube	
Defrosting method		—	
Optional parts		Joint: CMY-Y62-G-E, Header: CMY-Y64/68-G-E	

Notes:

\*1 Nominal conditions

	Indoor	Outdoor	Pipe length	Level difference	External static press.
Cooling	27°C DB/19°C WB (81°F DB/66°F WB)	35°C DB (95°F DB)	7.5m (24-9/16ft.)	0m (0ft.)	0 Pa

\*2 Up to 150% can be connected. However, up to 130% for simultaneous operation.

\*3 External static pressure option is available (30 Pa/3.1 mmH<sub>2</sub>O).

\*4 187 (413) for PUMY-CP250/300YBM2-BS.

\*5 Liquid pipe diameter: 12.7mm, in case of farthest piping length (farthest indoor unit from outdoor unit) is longer than 90m, or connect with PEFY-P200/250.

\*Nominal conditions \*1 are subject to ISO 15042.

\*Due to continuing improvement, above specification may be subject to change without notice.

OUTDOOR UNIT

S-series

PUMY-SP VKM2 (-BS) **NEW**

Advantages of CITY MULTI

Outdoor/Heat source unit

Indoor unit

Remote Controller

Lossnay

Installation information

## Specifications

Model	PUMY-SP100VKM2 (-BS)		PUMY-SP125VKM2 (-BS)		PUMY-SP140VKM2 (-BS)		
Power source	1-phase 220-230-240 V, 50 Hz; 1-phase 220 V, 60 Hz						
Cooling capacity (Nominal)	*1 kW	11.2	14.0	15.5			
	*1 BTU/h	38,200	47,800	52,900			
	Power input kW	2.78	3.84	4.31			
	Current input A	12.89-12.33-11.82, 12.89	17.81-17.04-16.33, 17.81	19.99-19.12-18.32, 19.99			
Temp. range of cooling	EER kW/kW	4.03	3.65	3.60			
	Indoor temp. W.B.	15 to 24°C (59 to 75°F)					
	Outdoor temp.*3*4 D.B.	-5 to 52°C (23 to 126°F)					
Heating capacity (Nominal)	*2 kW	12.5	16.0	16.5			
	*2 BTU/h	42,650	54,600	56,300			
	Power input kW	2.58	3.90	4.02			
	Current input A	11.97-11.45-10.97, 11.97	18.09-17.30-16.58, 18.09	18.65-17.83-17.09, 18.65			
Temp. range of heating	COP kW/kW	4.84	4.10	4.10			
	Indoor temp. D.B.	15 to 27°C (59 to 81°F)					
Indoor unit connectable	Outdoor temp. W.B.	-20 to 15°C (-4 to 59°F)					
	Total capacity	50 to 130% of outdoor unit capacity					
Sound pressure level (Cooling/Heating)*5 (measured in anechoic room)	Model/Quantity	CITY MULTI					
	Quantity	15-125/7	15-140/10	15-140/12			
Refrigerant piping diameter	Liquid pipe mm (in.)	9.52 (3/8) Flared					
	Gas pipe mm (in.)	15.88 (5/8) Flared					
Fan	Type x Quantity	Propeller Fan x 1					
	Air flow rate	m <sup>3</sup> /min	75	83	83		
		L/s	1,283	1,383	1,383		
		cfm	2,791	2,931	2,931		
*6 Motor output kW	0.20 x 1						
Compressor	Type x Quantity	Twin rotary hermetic compressor x 1					
	Starting method	Inverter					
	Motor output kW	2.8	3.4	3.6			
External finish	Galvanized Steel Sheet Munsell No. 3Y 7.8/1.1						
External dimension H x W x D	mm	981 x 1050 x 330 (+25)					
	in.	38-5/8 x 41-3/8 x 13 (+1)					
Protection devices	High pressure protection	High pressure switch					
	Inverter circuit (COMP./FAN)	Overcurrent detection, Overheat detection (Heat Sink thermistor)					
	Compressor	Compressor thermistor, Overcurrent detection, Compressor protector					
	Fan motor	Overheating, Voltage protection					
Refrigerant	Type x original charge	R410A 3.5kg					
Net weight	kg (lbs)	93 (205) *7					
Heat exchanger	Cross Fin and Copper tube						
Defrosting method	Reversed refrigerant circuit						
Optional parts	Joint: CMY-Y62-G-E, Header: CMY-Y64/68-G-E, Air protect guide:PAC-SH95AG-E						

## Notes:

\*1, \*2 Nominal conditions

	Indoor	Outdoor	Pipe length	Level difference
Cooling	27°C DB/19°C WB (81°F DB/66°F WB)	35°C DB (95°F DB)	7.5m (24-9/16ft.)	0m (0ft.)
Heating	20°C DB (68°F DB)	7°C DB/6°C WB (45°F DB/43°F WB)	7.5m (24-9/16ft.)	0m (0ft.)

\*3 10 to 52°C D.B. [50 to 126°F D.B.], when connecting following models: PKFY-P15/20/25/32VLM, PFFY-P20/25/32VLEM, PFFY-P20/25/32VLRM(M), PFFY-P20/25/32VCM, PFFY-P20/25/32VKM, PEFY-P-VMA4 and M-Series, S-Series, and P-Series type indoor unit with branch box, M-Series type indoor unit with connection kit.

\*4 -15 to 52°C D.B. [5 to 126°F D.B.], when using an optional air protect guide [PAC-SH95AG-E]. However, this condition does not apply to the indoor unit listed in\*3.

\*5 Cooling mode/Heating mode

\*6 External static pressure option is available (30 Pa/3.1 mmH<sub>2</sub>O).

\*7 94 (207), for PUMY-SP100/125/140VKM2-BS. 95 (209), for PUMY-SP100/125/140YKM2-BS.

\*Nominal conditions \*1,\*2 are subject to ISO 15042.

\*Due to continuing improvement, above specification may be subject to change without notice.

OUTDOOR UNIT

**S-series**

PUMY-SP YKM2 (-BS) **NEW**



**Specifications**

Model	PUMY-SP100YKM2 (-BS)		PUMY-SP125YKM2 (-BS)		PUMY-SP140YKM2 (-BS)	
Power source	3-phase 380-400-415 V, 50 Hz; 3-phase 380 V, 60 Hz					
Cooling capacity (Nominal)	*1 kW	11.2	14.0	15.5		
	*1 BTU/h	38,200	47,800	52,900		
	Power input kW	2.78	3.84	4.31		
	Current input A	4.45-4.22-4.07, 4.45	6.14-5.83-5.62, 6.14	6.89-6.55-6.31, 6.89		
	EER kW/kW	4.03	3.65	3.60		
Temp. range of cooling	Indoor temp. W.B.	15 to 24°C (59 to 75°F)				
	Outdoor temp.*3*4 D.B.	-5 to 52°C (23 to 126°F)				
Heating capacity (Nominal)	*2 kW	12.5	16.0	16.5		
	*2 BTU/h	42,650	54,600	56,300		
	Power input kW	2.58	3.90	4.02		
	Current input A	4.13-3.92-3.78, 4.13	6.24-5.93-5.71, 6.24	6.43-6.11-5.89, 6.43		
	COP kW/kW	4.84	4.10	4.10		
Temp. range of heating	Indoor temp. D.B.	15 to 27°C (59 to 81°F)				
	Outdoor temp. W.B.	-20 to 15°C (-4 to 59°F)				
Indoor unit connectable	50 to 130% of outdoor unit capacity					
	Model/Quantity	CITY MULTI	15-125/7	15-140/10	15-140/12	
Sound pressure level (Cooling/Heating)*5 (measured in anechoic room)	dB <A>	51/54	53/56	54/56		
Refrigerant piping diameter	Liquid pipe mm (in.)	9.52 (3/8) Flared				
	Gas pipe mm (in.)	15.88 (5/8) Flared				
Fan	Type x Quantity	Propeller Fan x 1				
	Air flow rate	m³/min	75	83		
		L/s	1,283	1,383		
		cfm	2,791	2,931		
*6 Motor output kW	0.20 x 1					
Compressor	Type x Quantity	Twin rotary hermetic compressor x 1				
	Starting method	Inverter				
	Motor output kW	2.6	3.5	3.7		
External finish	Galvanized Steel Sheet Munsell No. 3Y 7.8/1.1					
External dimension H x W x D	mm	981 x 1050 x 330 (+25)				
	in.	38-5/8 x 41-3/8 x 13 (+1)				
Protection devices	High pressure protection	High pressure switch				
	Inverter circuit (COMP./FAN)	Overcurrent detection, Overheat detection (Heat Sink thermistor)				
	Compressor	Compressor thermistor, Overcurrent detection, Compressor protector				
	Fan motor	Overheating, Voltage protection				
Refrigerant	Type x original charge	R410A 3.5kg				
Net weight	kg (lbs)	94 (207) *7				
Heat exchanger	Cross Fin and Copper tube					
Defrosting method	Reversed refrigerant circuit					
Optional parts	Joint: CMY-Y62-G-E, Header: CMY-Y64/68-G-E, Air protect guide:PAC-SH95AG-E					

**Notes:**

\*1, \*2 Nominal conditions

	Indoor	Outdoor	Pipe length	Level difference
Cooling	27°C DB/19°C WB (81°F DB/66°F WB)	35°C DB (95°F DB)	7.5m (24-9/16ft.)	0m (0ft.)
Heating	20°C DB (68°F DB)	7°C DB/6°C WB (45°F DB/43°F WB)	7.5m (24-9/16ft.)	0m (0ft.)

\*3 10 to 52°C D.B. [50 to 126°F D.B.], when connecting following models: PKFY-P15/20/25/32VLM, PFFY-P20/25/32VLEM, PFFY-P20/25/32VLRM(M), PFFY-P20/25/32VCM, PFFY-P20/25/32VKM, PEFY-P-VMA4 and M-Series, S-Series, and P-Series type indoor unit with branch box, M-Series type indoor unit with connection kit.

\*4 -15 to 52°C D.B. [5 to 126°F D.B.], when using an optional air protect guide [PAC-SH95AG-E]. However, this condition does not apply to the indoor unit listed in\*3.

\*5 Cooling mode/Heating mode

\*6 External static pressure option is available (30 Pa/3.1 mmH<sub>2</sub>O).

\*7 94 (207), for PUMY-SP100/125/140YKM2-BS. 95 (209), for PUMY-SP100/125/140YKM2-BS.

\*Nominal conditions \*1,\*2 are subject to ISO 15042.

\*Due to continuing improvement, above specification may be subject to change without notice.



OUTDOOR UNIT

S-series

PUMY-P YKM3 (-BS) **NEW**

Advantages of CITY MULTI

Outdoor/Heat source unit

Indoor unit

Remote Controller

Lossnay

Installation information

## Specifications

Model		PUMY-P175YKM3 (-BS)	PUMY-P200YKM3 (-BS)	PUMY-P225YKM3 (-BS)
Power source		3-phase 380-400-415 V, 50 Hz; 3-phase 380 V, 60 Hz		
Cooling capacity (Nominal)	*1 kW	20.0	22.4	25.0
	*1 BTU/h	68,200	76,400	85,300
Power input	kW	5.00	5.74	6.54
	A	8.94-8.50-8.19, 8.94	10.03-9.53-9.18, 10.03	11.17-10.61-10.23, 11.17
	kW/kW	4.00	3.90	3.82
Temp. range of cooling	Indoor temp. W.B.	15.0 to 24.0°C (59 to 75°F)		
	Outdoor temp. *3*4 D.B.	-5.0 to 52.0°C (23 to 126°F)		
Heating capacity (Nominal)	*2 kW	22.4	25.0	27.3
	*2 BTU/h	76,400	85,300	93,200
	kW	5.14	5.99	6.80
	A	9.19-8.73-8.42, 9.19	10.47-9.94-9.58, 10.47	11.61-11.03-10.63, 11.61
Temp. range of heating	Indoor temp. D.B.	15.0 to 27.0°C (59 to 81°F)		
	Outdoor temp. W.B.	-20.0 to 15.0°C (-4 to 59°F)		
Indoor unit connectable	Total capacity	50 to 130% of outdoor unit capacity		
	Model/Quantity	CITY MULTI		
Sound pressure level (measured in anechoic room)	*5 dB <A>	57/61	57/61	58/63
	Refrigerant piping diameter	9.52 (3/8) Flared *6		
Fan	Type x Quantity	Propeller Fan x 2		
	Air flow rate	m <sup>3</sup> /min	134	143.8
Compressor	Type x Quantity	Scroll hermetic compressor x 1		
	Starting method	Inverter		
	Motor output	0.20 + 0.20		
	kW	4.3	5.2	5.4
External finish	External dimension H x W x D	Galvanized Steel Sheet Munsell No. 3Y 7.8/1.1		
	mm	1,338 x 1,050 x 330 (+25)		
Protection devices	High pressure protection	High pressure switch		
	Inverter circuit (COMP./FAN)	Overcurrent detection, Overheat detection (Heat Sink thermistor)		
	Compressor	Compressor thermistor, Overcurrent detection, Compressor protector		
Refrigerant	Type x original charge	R410A 7.3kg		
	Net weight	138 (305) *7		
Heat exchanger		Cross Fin and Copper tube		
Defrosting method		Reversed refrigerant circuit		
Optional parts		Joint: CMY-Y62-G-E, Header: CMY-Y64/68-G-E		

## Notes:

\*1,\*2 Nominal conditions

	Indoor	Outdoor	Pipe length	Level difference
Cooling	27°C DB/19°C WB (81°F DB/66°F WB)	35°C DB (95°F DB)	7.5m (24-9/16ft.)	0m (0ft.)
Heating	20°C DB (68°F DB)	7°C DB/6°C WB (45°F DB/43°F WB)	7.5m (24-9/16ft.)	0m (0ft.)

\*3 10 to 52°C D.B. : When connecting PKFY-P15/20/25/32VLM, PFFY-P20/25/32VKM, PFFY-P20/25/32VLEM, PFFY-P20/25/32VLRM(M), PFFY-P20/25/32VCM, PFFY-P-VMA4, M, S and P series indoor unit.

\*4 -15 to 52°C D.B. [5 to 126°F D.B.], when using an optional air protect guide [PAC-SH95AG-E]. However, this condition does not apply to the indoor unit listed in\*3.

\*5 Cooling mode / Heating mode

\*6 Liquid pipe diameter: 12.7mm in case that the farthest piping length is longer than 60m, or piping length from outdoor unit to a branch box is longer than 20m.

\*7 139 (307) for PUMY-P175/200/225YKM3-BS.

\*Nominal conditions \*1,\*2 are subject to ISO 15042.

\*Due to continuing improvement, above specification may be subject to change without notice.

PUMY-P YBM2 (-BS) **NEW**

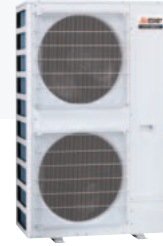

**Specifications**

Model		PUMY-P250YBM2 (-BS)	PUMY-P300YBM2 (-BS)	
Power source		3-phase 380-400-415 V, 50 Hz; 3-phase 380 V, 60 Hz		
Cooling capacity (Nominal)	*1 kW	28.0	33.5	
	*1 BTU/h	95,500	114,300	
Temp. range of cooling	Power input kW	6.83	8.17	
	Current input A	11.16-10.60-10.22, 11.16	13.35-12.68-12.22, 13.35	
	EER kW/kW	4.10	4.10	
	Indoor temp. W.B.	15.0 to 24.0°C (59 to 75°F)		
	Outdoor temp.*3*4 D.B.	-5.0~52.0°C (23 to 126°F)		
Heating capacity (Nominal)	*2 kW	31.5	37.5	
	*2 BTU/h	107,400	127,900	
	Power input kW	6.06	7.36	
	Current input A	9.90-9.41-9.07, 9.90	12.02-11.42-11.01, 12.02	
	COP kW/kW	5.20	5.10	
Temp. range of heating	Indoor temp. D.B.	15.0 to 27.0°C (59 to 81°F)		
	Outdoor temp. W.B.	-20.0 to 15.0°C (-4 to 59°F)		
Indoor unit connectable	Total capacity		50 to 130% of outdoor unit capacity	
	Model/Quantity	CITY MULTI		
		15-250/21	15-250/25	
Sound pressure level (measured in anechoic room)	*5 dB <A>	59/60	60/62	
Refrigerant piping diameter	Liquid pipe mm (in.)	9.52(3/8) Flared *8	12.7(1/2) Flared	
	Gas pipe mm (in.)	22.2(7/8) Brazed	25.4(1) Brazed	
Fan	Type x Quantity	Propeller Fan x 2		
	Air flow rate	m³/min	187/183	187/197
		L/s	3116/3050	3116/3283
		cfm	6603/6462	6603/6956
*5 Motor output	kW	0.375 + 0.375		
Compressor	Type x Quantity	Scroll hermetic compressor x 1		
	Starting method	Inverter		
*6 Motor output	kW	6.65	7.35	
External finish		Galvanized Steel Sheet Munsell No. 3Y 7.8/1.1		
External dimension H x W x D	mm	1,662 x 1,050 x 460 (+45)		
	in.	65-7/16 x 41-11/32 x 18-7/64 (+1-49/64)		
Protection devices	High pressure protection	High pressure switch		
	Inverter circuit (COMP./FAN)	Overcurrent detection, Overheat detection (Heat Sink thermistor)		
	Compressor	Compressor thermistor, Overcurrent detection, Compressor protector		
	Fan motor	Overcurrent, Overheating, Voltage protection		
Refrigerant	Type x original charge	R410A 9.3kg		
Net weight	kg (lbs)	192 (424) *7		
Heat exchanger		Ring Fin and Copper tube		
Defrosting method		Reversed refrigerant circuit		
Optional parts		Joint: CMY-Y62-G-E, Header: CMY-Y64/68-G-E		

**Notes:**

\*1, \*2 Nominal conditions

	Indoor	Outdoor	Pipe length	Level difference	External static press.
Cooling	27°C DB/19°C WB (81°F DB/66°F WB)	35°C DB (95°F DB)	7.5m (24-9/16ft.)	0m (0ft.)	0 Pa
Heating	20°C DB	7°C DB/6°C WB (45°F DB/43°F WB)	7.5m (24-9/16ft.)	0m (0ft.)	0 Pa

\*3 10 to 52°C D.B. : When connecting PKFY-P15/20/25/32VLM, PFFY-P20/25/32VKM, PFFY-P20/25/32VLEM, PFFY-P20/25/32VLRM(M), PFFY-P20/25/32VCM, PEFY-P-VMA4, M, S and P series indoor unit.

\*4 -15 to 52°C D.B. [5 to 126°F D.B.], when using an optional air protect guide [PAC-SH21AG-E]. However, this condition does not apply to the indoor unit listed in\*3.

\*5 Cooling mode/Heating mode

\*6 External static pressure option is available (30 Pa/3.1 mmH<sub>2</sub>O).

\*7 194 (428) for PUMY-P250/300YBM2-BS.

\*8 Liquid pipe diameter: 12.7mm. in case of farthest piping length (farthest indoor unit from outdoor unit) is longer than 90m, or connect with PEFY-P200/250.

\*Nominal conditions \*1, \*2 are subject to ISO 15042.

\*Due to continuing improvement, above specification may be subject to change without notice.

## Optional Parts for Outdoor Units

### For PUMY-Series

Description	Model	Remarks
Air protect guide	PAC-SH95AG-E	For PUMY-SP VKM2/YKM2, PUMY-CP VKM2/YKM2, PUMY-P YKM3* *Two are needed for PUMY-CP175/200/225YKM2, PUMY-P175/200/225YKM3
	PAC-SK21AG-E	Two are needed for PUMY-(C)P250/300YBM2
Air outlet guide	PAC-SH96SG-E	For PUMY-SP VKM2/YKM2, PUMY-CP VKM2/YKM2, PUMY-P YKM3* *Two are needed for PUMY-CP175/200/225YKM2, PUMY-P175/200/225YKM3
	PAC-SK22SG-E	Two are needed for PUMY-(C)P250/300YBM2
Drain socket	PAC-SG61DS-E	For PUMY-SP VKM2/YKM2, PUMY-CP VKM2/YKM2, PUMY-P YKM3
	PAC-SK27DS-E	For PUMY-(C)P250/300YBM2
Centralized drain pan	PAC-SH97DP-E	For PUMY-SP VKM2/YKM2, PUMY-CP VKM2/YKM2, PUMY-P YKM3
	PAC-SJ83DP-E	For PUMY-(C)P250/300YBM2
Connection kit	PAC-LV11M-J	
Branch pipe	CMY-Y62-G-E	For 2 branches
Header	CMY-Y64-G-E	For 4 branches
	CMY-Y68-G-E	For 8 branches



# Y-series

## PUCY/PUHY

These models are provided with high-performance inverter compressors to achieve high energy-saving performance. A wide lineup of models with up to 60 HP can be applied to various usage.



The CITY MULTI Y-Series (for large applications) makes use of a two-pipe refrigerant system, and realizes enhanced cooling capacity at high outside air temperatures. The compact outdoor unit utilizes R410A refrigerant and an INVERTER-driven compressor to use energy effectively. The CITY MULTI Series can be configured for all applications. Up to 50 (Y-Series) indoor units can be connected with up to 130% connected capacity to maximize engineering design options. This feature allows easy air conditioning in each area with convenient individual controllers.

## System structure example

No separate transfer device such as pump required

### System Pipe Lengths

We use a two-pipe system. Unlike chiller system, VRF system does not require pumps or control panels, and these functions are integrated into the outdoor units. The piping can be designed appropriately to any building design by using joints and headers and flexibly adapted to many applications.

**Outdoor unit**



**PUCY-Series**

- Further enhanced energy savings
- High cooling capacity at high outdoor air temperatures
- High reliability

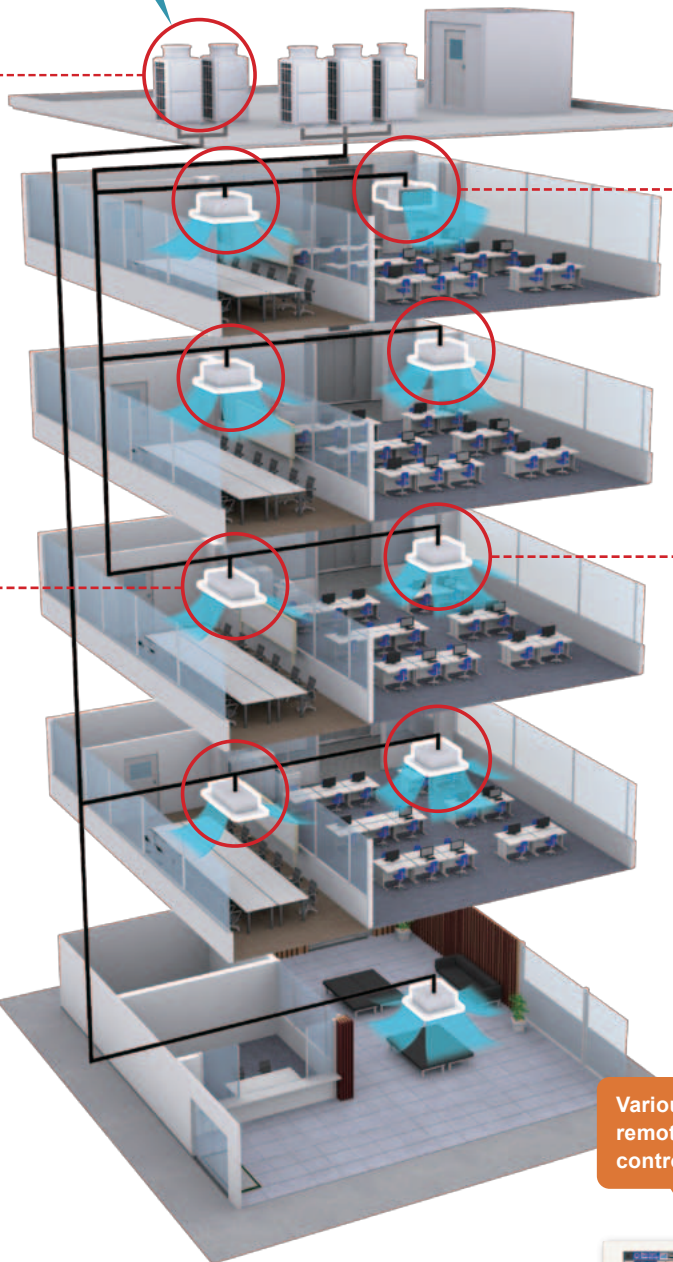

**Ceiling concealed**



**PEFY-P VMA(L)-E4**

- Thin design with a body height of 250 mm [9-7/8 in.]
- The rear or bottom air inlet can be selected depending on the installation situation

**2-way air flow**



**PLFY-P VLMD-E**

- Stylish design with well blended air inlet
- The unit is 290 mm [11-7/16 in.] in height and usable in corridor or a narrow room

**4-way air flow**



**PLFY-P VEM-PA**

- 3D i-see Sensor and versatile airflow variation provide comfort to all corners of the room.

Various control from local remote controllers to centralized controllers is possible



AE-200E



PAR-41MAA

### Various lineups

CITY MULTI includes various types of outdoor units, indoor units and controllers. The customers can easily select the models according to their situation. The units can be individually controlled, and it is possible to start or stop the air conditioner and set the conditions, such as temperature, in each room.

# YKD-series

The YKD series not only realize high energy savings and quality performance from Mitsubishi Electric, they also feature further improved reliability. This is especially important in the Asian climate which requires enhanced cooling capacity at high outside air temperatures.



**S** module



**L** module



**XL** module

\* Product images are PUCY models

## Further enhanced energy savings

- Higher rated EER in all models (compared to conventional model)
- Improved energy efficiency under partial-load conditions
- Evaporating temperature control provides further energy savings

## Cooling capacity at high outdoor air temperatures

- Operation guaranteed up to an outside air temperature (intake temperature) of 52°C
- The assist function for enhanced cooling power at high outside air temperatures
- Rapid mode reduces startup time

## High reliability

- Structure features a low-pressure shell compressor, polyurethane coated circuit boards and other high-reliability parts
- Emergency operation mode and rotation function, etc. contribute to enhanced operation reliability

## High installation flexibility

- Two-pipe system and M-NET wiring facilitate installation
- Selectable external static pressure setting to match site conditions



# Further enhanced energy savings

## 1. Higher EER ratings

Compared to conventional products (YKA series), the YKD series achieves improved EER in all cooling-only models and heat pump models from 8 to 60HP. The 8HP model (PUCY-P200YKD) boasts 20% improvement.

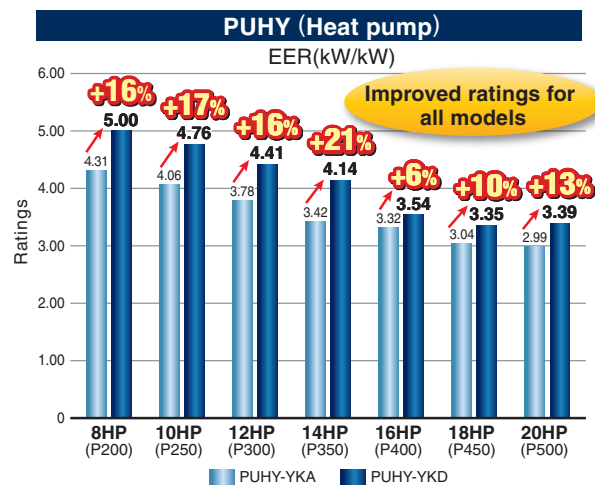
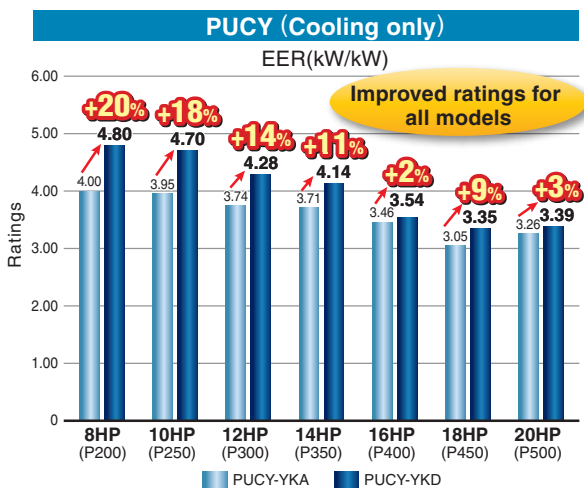

## 2. High partial-load performance

At times when the temperature difference between daytime and morning/evening is large, efficient operation also under low-load conditions is important. The multi-port design of the compressor helps to improve partial-load efficiency compared to conventional models, enabling highly efficient operation throughout the year, including season changeover periods.

Temperature in Tokyo in 2021 (by month)

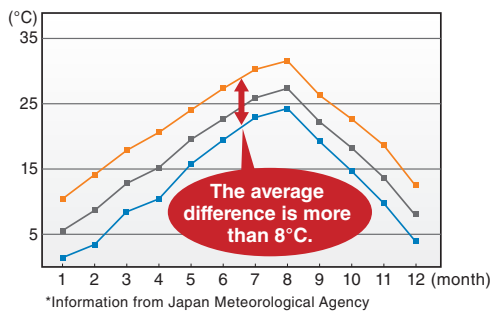

Temperature in Singapore in 2021 (by month)

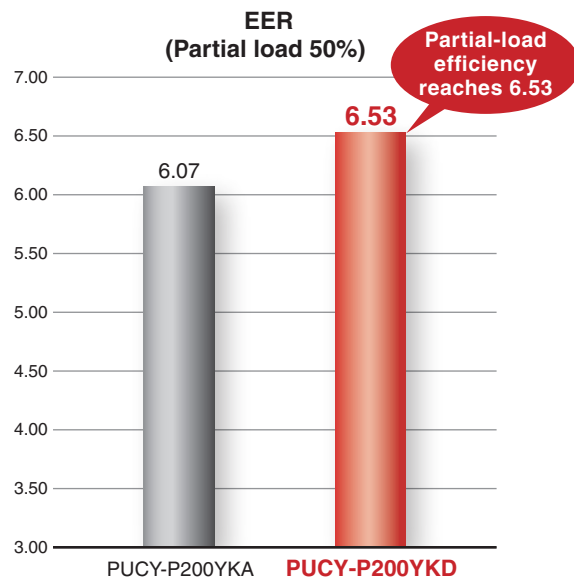
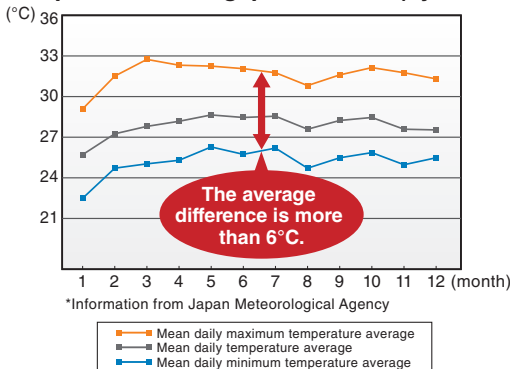

# Further enhanced energy savings

## 3. Energy saving assist function

In addition to the basic energy saving design, energy saving assist functions can be activated easily via DIP switch settings. This allows matching the equipment to various installation patterns.

### Evaporating temperature control

During cooling operation, the temperature of the refrigerant can be controlled according to the air conditioning load. This helps energy efficient operation.

#### ■ Normal mode

The evaporating temperature is kept constant regardless of the load. Even at low loads, the normal evaporating temperature does not change, which leads to energy waste during partial load operation.

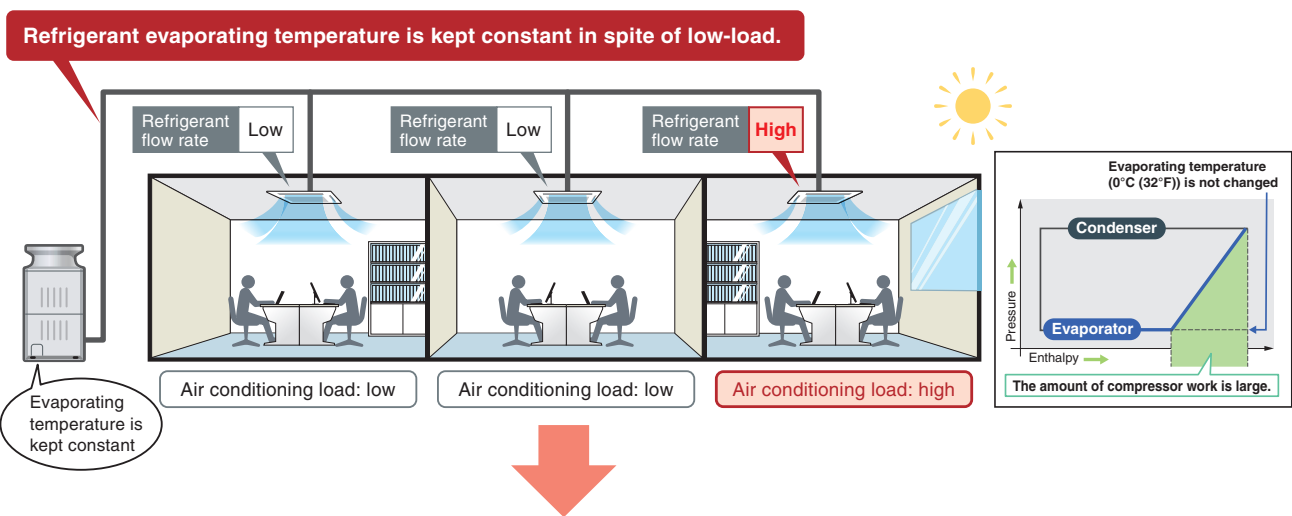

#### ■ Smart evaporation temperature control mode

The YKD series supports evaporating temperature control which adjusts the refrigerant evaporating temperature. Two control methods are available: fixed control and automatic shift control.

\* Changing the evaporating temperature is achieved by changing DIP switch settings on the outdoor unit. Refer to "Evaporating temperature setting method" and the Service Handbook for details.

\* Raising the evaporating temperature will lower the latent heat processing capability. Select the appropriate mode for the installation location, taking factors such as ambient temperature into consideration.

### 1. Fixed control

The target evaporating temperature is changed and controlled to be constant. Selecting an evaporating temperature that is higher than for normal cooling will reduce the load of the compressor and improve operation efficiency.

#### • Concept of evaporating temperature control (fixed control)

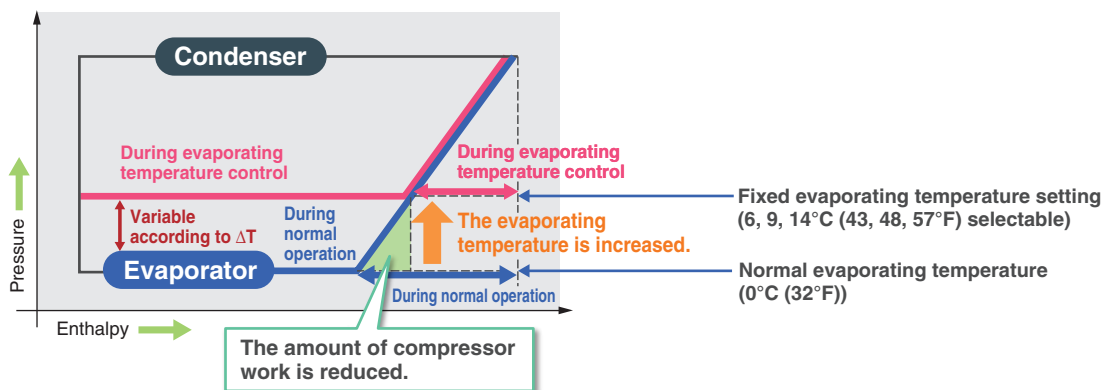

\* Because evaporating temperature will constantly be higher, cooling capacity is reduced, which may result in the room not reaching the set temperature.

\* To change the evaporating temperature setting, it is necessary to change the setting of the DIP switch on the outdoor unit.

## 2. Automatic shift control

Evaporating temperature is shifted according to the air conditioning load ( $\Delta T$ ). When approaching the set temperature, evaporating temperature is raised to reduce compressor workload and save energy. Four control patterns can be selected.

### • Concept of evaporating temperature control (automatic shift control)

#### 4 patterns for setting target evaporating temperature

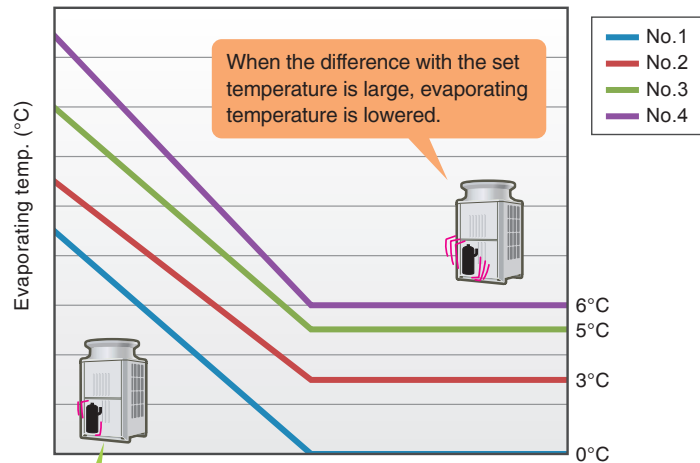

Evaporating temperature is raised when approaching the set temperature.

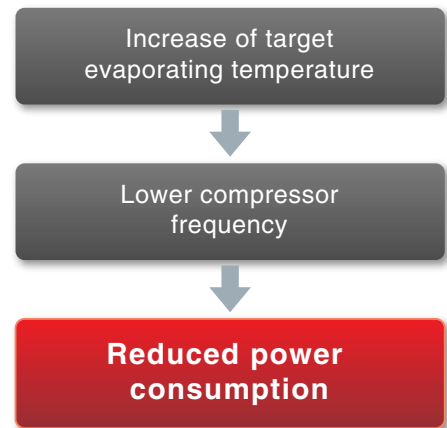

\*1 To activate evaporating temperature control, use terminal external input.  
\*2 To change the evaporating temperature setting, it is necessary to change the setting of the DIP switch on the outdoor unit.

**High load** At start of operation / With many people inside the room

**Low load** As room temperature approaches set temperature

Evaporating temperature is changed according to the difference between room temperature and set temperature.

### Suitable situations

- (1) Locations with mainly sensible heat load by OA equipment (offices and similar)
- (2) Relatively low-load conditions during air conditioning season (mornings or nights)
- (3) When higher temperature of discharge air is desired in windy conditions

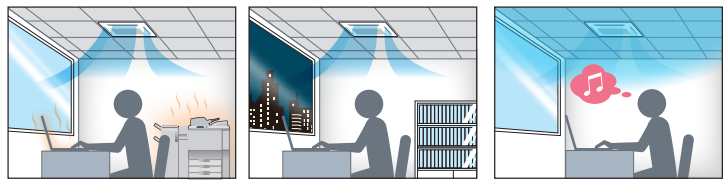



# Cooling capacity at high outdoor air temperatures

## 1. Cooling operation possible up to intake temperature of 52°C



In built-up areas with a high density of buildings, winds may be blocked, causing an accumulation of warm air in the vicinity of the outdoor unit. Because the operation range of the YKD series has been guaranteed up to 52°C (125°F), operation will remain stable even in such situations.

### Example of flow analysis

■ Conditions : Outdoor air temperature = 35°C (DB), Room temperature = 27°C (DB)

Built-up area with buildings and outdoor units

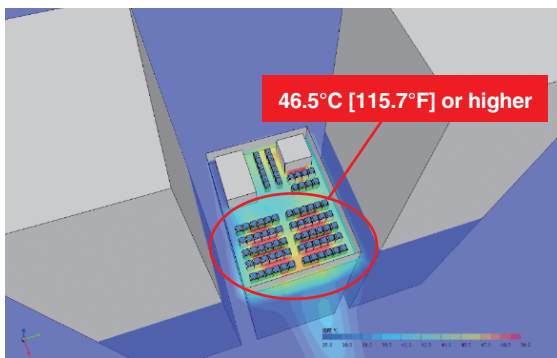

If the passage of air is blocked in a built-up area, the high-temperature air discharged from the outdoor units may be kept around the units.

Installation on each floor a high-rise building

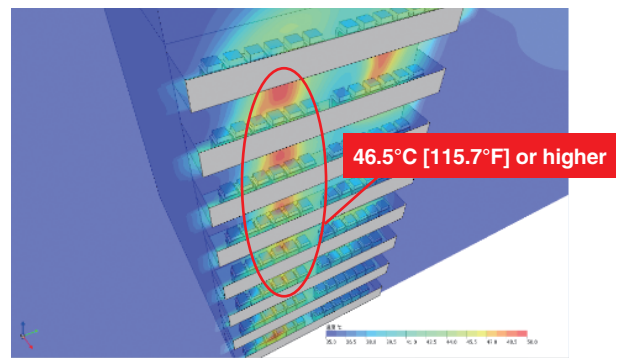

When the outdoor units are installed on balconies, the high-temperature air discharged from the units may be kept in by upper balconies.

### Temperature range for cooling

#### PUHY-P YKD

-5°C [23°F]

to

52°C [125°F]

\* Cooling performance will drop at temperatures exceeding 35°C.

### Suitable situations

Installation in locations such as on balconies or between buildings, where high-temperature air may tend to accumulate.

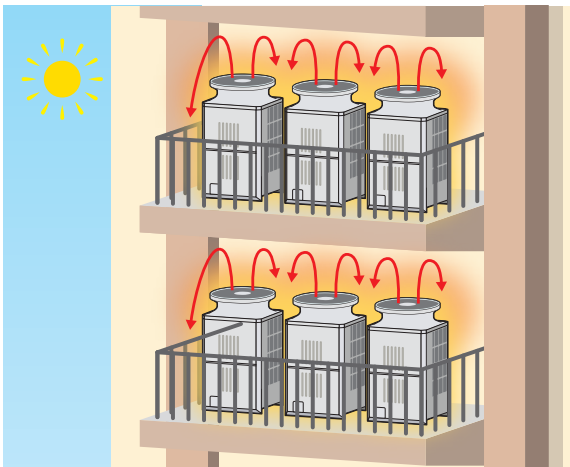

## 2. Cooling operation assist function

### Capacity assist mode

During cooling operation at high outside temperatures, cooling capacity tends to be decreased. The YKD series provides capacity assist mode where the fan speed is automatically raised when the outside temperature reaches or exceeds around 38°C. This prevents a drop in cooling capacity during operation at high outside air temperatures. Comfort is improved, thanks to continued high performance of the unit.

- \* Requires a DIP switch setting
- \* This function will be disabled when the unit is set to the outdoor high static pressure setting or to the night mode setting. The outdoor unit will make more noise due to an increased airflow. Choose the mode according to installation requirements.

Cooling capacity, with indoor units running at 100%

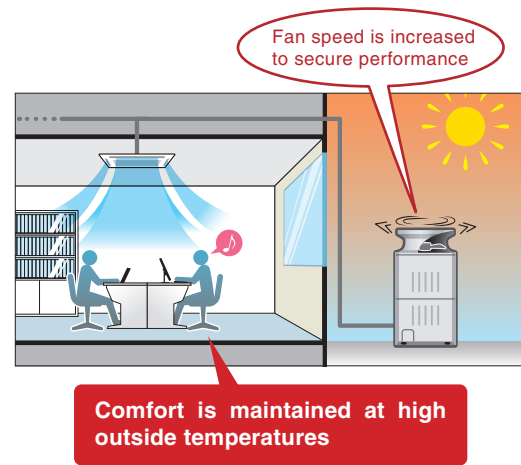
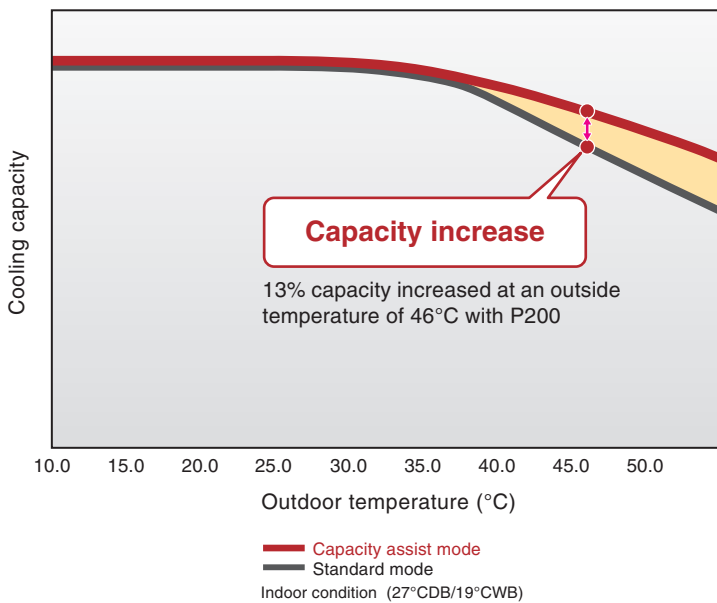

### Rapid mode during startup (Quick-start up)

The rotation speed of the compressor can be raised during the first 30 minutes after cooling startup, to quickly establish comfortable conditions when returning home or at the start of a workday. Restarting after a power outage will also be faster, to quickly cool down the room.

- \* Requires a DIP switch setting
- \* Selecting this mode may increase operation noise. Choose the mode according to installation requirements.

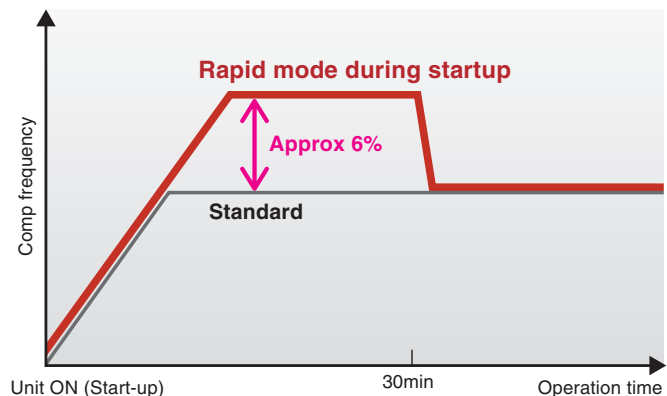
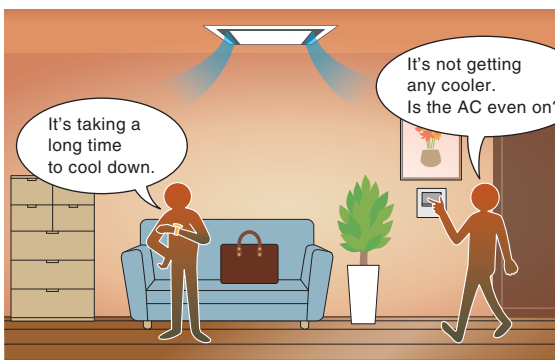

The room does not cool off very quickly, and it takes a while before the room becomes comfortable.

# Key Technologies

All major parts of YKD series products reflect technological excellence of Mitsubishi Electric. This results in high energy efficiency, enhanced cooling capacity at high outside air temperatures, and further improved reliability.

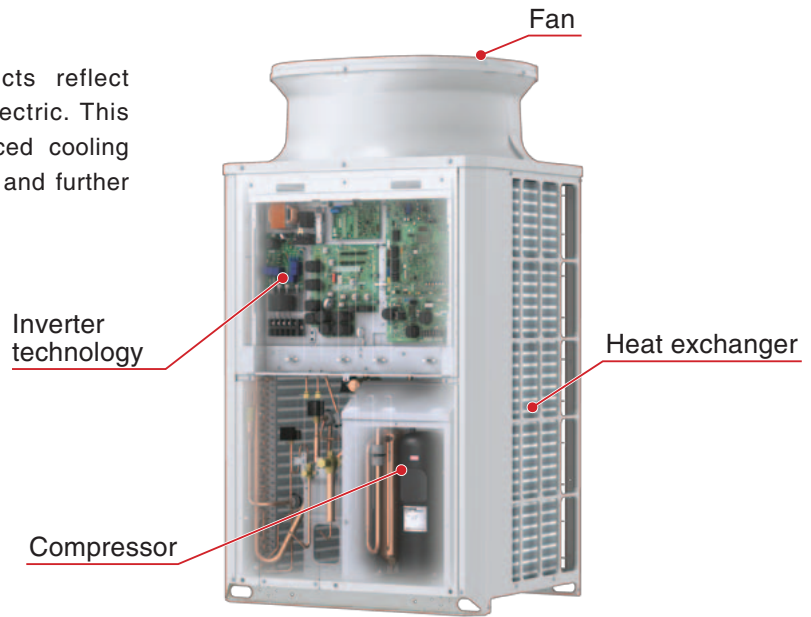

## Inverter technology

As a manufacturer of general electric equipment, our inverter-related components are developed and manufactured using Mitsubishi Electric technology.

**All compressors are inverter-driven type and developed and manufactured by Mitsubishi Electric**



**The compressor varies its speed to match the indoor cooling or heating demand, thus it only consumes the energy amount of energy required.**

When an inverter driven system is operating at partial load, the energy efficiency of the system is significantly higher than that of a standard fixed speed, non inverter system. The fixed speed system can only operate at 100%, although full load condition is not prevailed all time. Therefore, fixed speed systems cannot match the annual efficiency of inverter driven systems.

**Developed by Mitsubishi Electric**

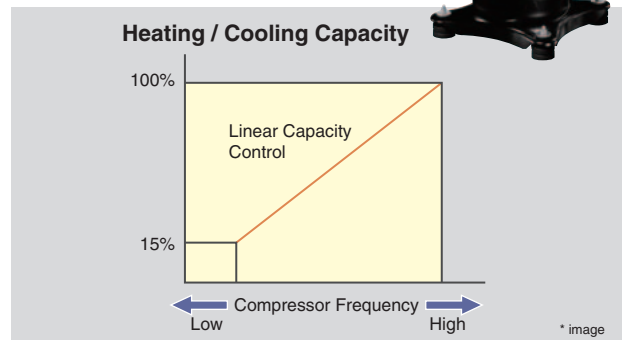

\* Values vary depending on actual conditions, such as ambient temperature.

**Intelligent Power Module (IPM) manufactured by Mitsubishi Electric**



Power modules manufactured by Mitsubishi Electric\* are installed in the inverter circuit boards that drive compressors and fans. Furthermore, a specialized drive circuit that ensures excellent performance make a high-quality, high-performance inverter possible.

**IPM technology ensures effective operation even at lower partial load and realizes automatic control to operate the air conditioners appropriately according to the situation, resulting in energy savings.**

\*Except models using PUHY-P200/250YKD module.

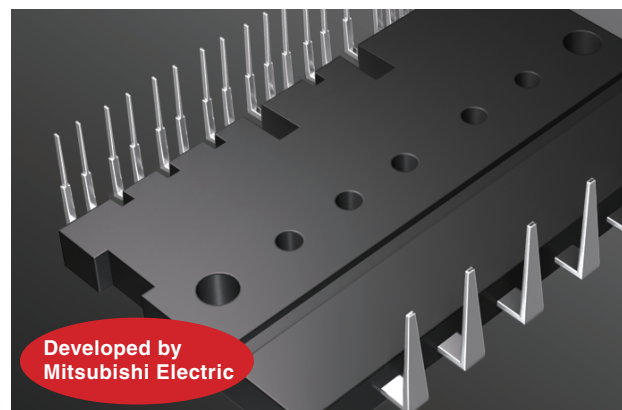

**Developed by Mitsubishi Electric**

# Compressor

## Multi-port mechanism



In addition to the conventional discharge port, the new series features two sub-ports, which performs according to the air conditioning load. This prevents excessive compression and improves operation efficiency.

### Conventional structure

		Operation pattern	
		Partial load	Rating, high pressure difference
Main port	Valve 1	Open	Open

### New structure with multi-port design

		Operation pattern	
		Partial load	Rating, high pressure difference
Main port	Valve 1	Open	Open
Sub-port	Valve 2/3	Open	Closed

The sub-port is opened during partial load operation to discharge the over-compressed gas.

### In case of partial load operation

#### Conventional structure

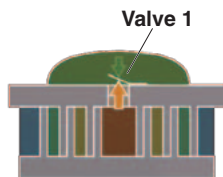
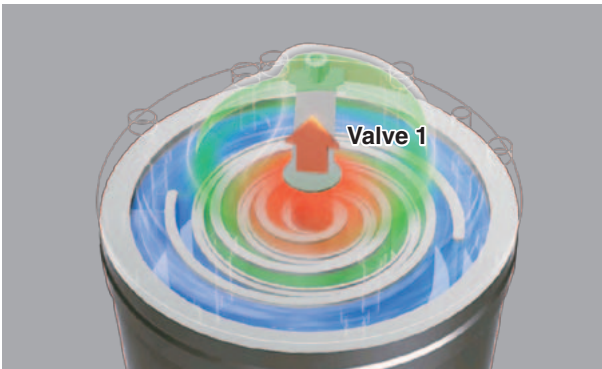

#### New structure with multi-port design

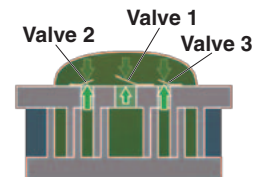
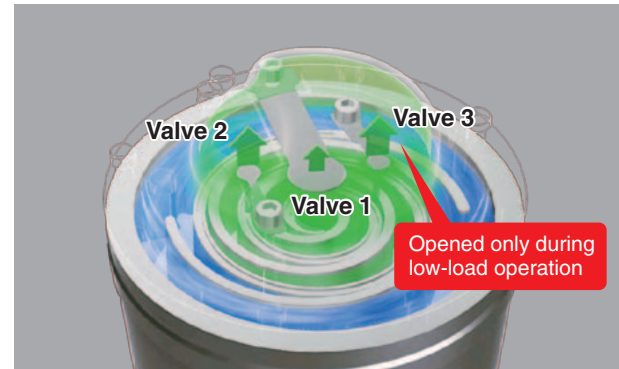

Opened only during low-load operation

#### ■ Concept of refrigerant pressure (during partial-load operation, etc.)

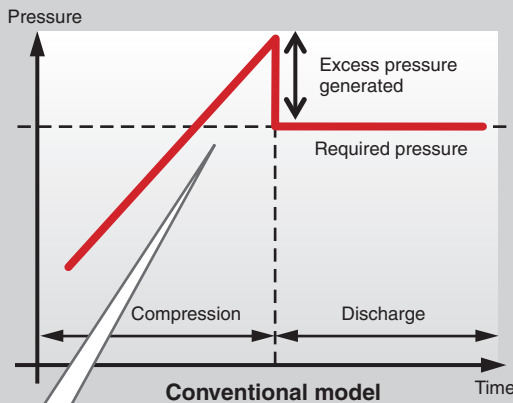

#### Conventional model

Because there is only one discharge port, compression capacity is first raised regardless of load, and then lowered to the target discharge pressure. This results in operation loss due to over-compression.

#### ■ Concept of refrigerant pressure

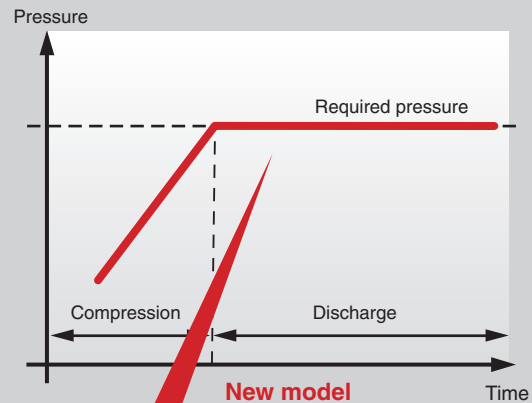

#### Multi-port

When the target discharge pressure is reached, the multi-ports are opened to release refrigerant gas. This reduces operation loss due to over-compression.



# Compressor

## Snap-in core

Mitsubishi Electric has incorporated a new and original production process that wraps a conductor directly around the split core to create a compact and highly efficient motor.

**Feature 1: Coils wound around each core**



Complete alignment winding

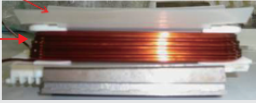

Assembly without welding

**Feature 2: Snap-in core**

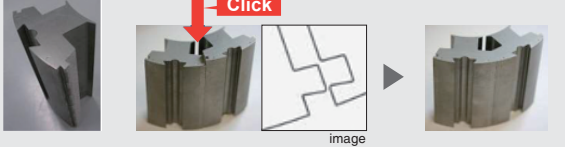

Click

image

**Compressor motor**

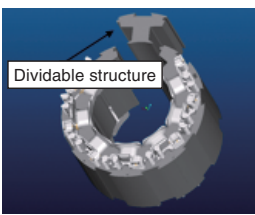

Dividable structure

Snap-in core

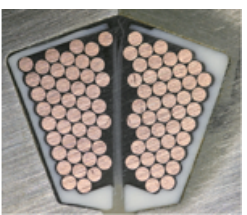

Cross section **Density: high**

Motor efficiency is high at low speeds when coil occupancy is high, thus improving compression efficiency for low-load operation.

## Improved high-efficiency motor \*Except for models using PUCY/PUHY-P200-350 YKD module.

Whereas the motor core of the conventional model had dead space between the insulator and insulation film, the YKD model has a smaller insulator with film on the inside. Consequently, the area for copper wire winding has increased by 9%. The wire diameter also was increased by two sizes, resulting in lower resistance and reduced insulation distance. This boosts motor efficiency, thus also improving compressor efficiency.

**YKA-Series**

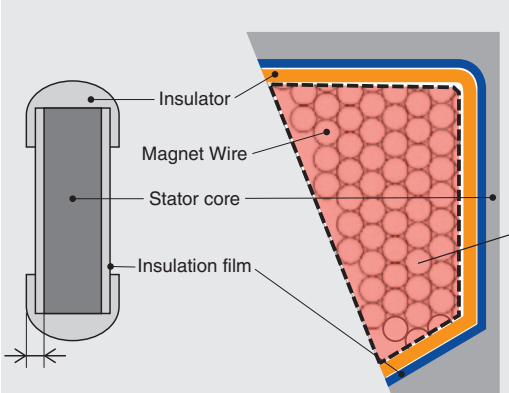

Insulator  
Magnet Wire  
Stator core  
Insulation film

The insulator section is large, and the area where the copper wire can be wound is small.

Increase in area available for winding

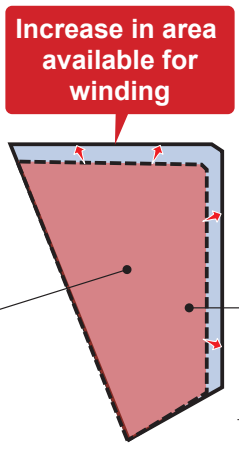

**YKD-Series**

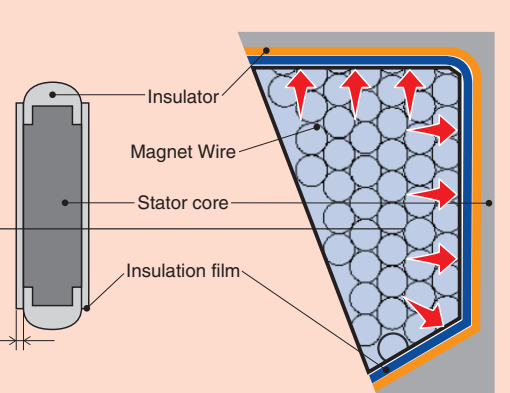

Insulator  
Magnet Wire  
Stator core  
Insulation film

Former insulator section now enables the use of larger gauge copper wire.

## IH (induction heating) warmer



In order to prevent refrigerant and oil from mixing while the air conditioner is stopped, it is necessary to always warm the compressor. Mitsubishi Electric provides the required heating by energizing the windings of the compressor (using a voltage that does not drive the compressor motor) instead of a belt type heater that applies heat from the outside, resulting in reduced loss and lower power consumption. In addition, remains on for 30 minutes after operation is stopped, and subsequently is switched on and off every 30 minutes. Standby power consumption therefore is lower than with a belt heater that is constantly powered.

\* Normally, the compressor is heated while the outdoor unit is stopped to prevent liquid refrigerant from remaining in the compressor and to evaporate the liquid refrigerant in the compressor.

IH warmer (without crankcase heater)

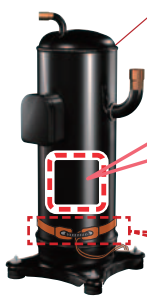

### Operation during air conditioner stop

On/off is repeated every 30 minutes



Crankcase heater not required

Standby power consumption can be reduced when the air conditioner is stopped overnight in offices or other locations.

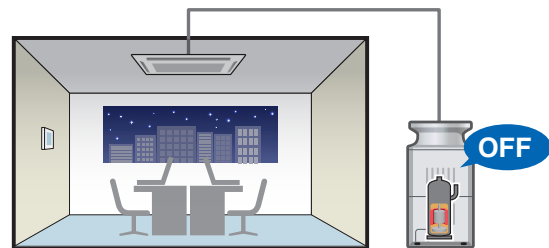

Internal heating reduces power consumption during standby. This provides an advantage over designs that are constantly powered.

## Fan

### Bell-mouth shape design realizes higher air discharge efficiency



This design reduces the fan input value and contributes to energy savings. In addition, more efficient air discharge improves stability during operation at high outside air temperatures.

Conventional model(YHA)

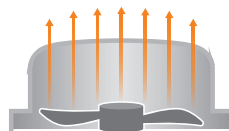

YKD

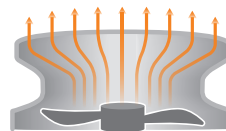

Air is expelled with higher efficiency by temporarily accumulating at the bottom of the bell-mouth shape.

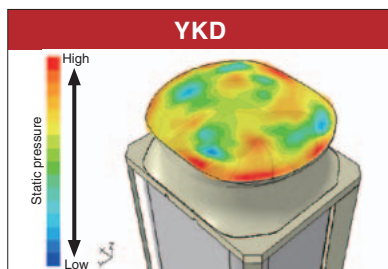
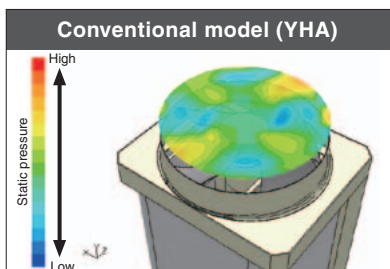

The change of the bell-mouth shape has realized energy saving operation by improving the static pressure while discharging air.

## Heat exchanger

### Grooves are formed in the copper pipe to improve the heat exchange performance.

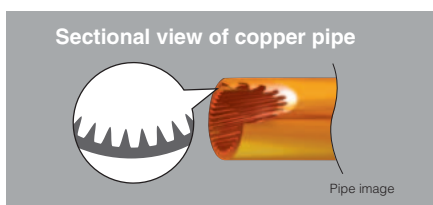

The grooved structure in the copper pipe of the heat exchanger increases the heat exchange area to contact with refrigerant.

# High reliability

## 1. Compressor

Liquid and gas refrigerants are separated beforehand by the accumulator to prevent liquid refrigerant from flowing into the compressor. Moreover, compressor structure is filled with low-pressure gas refrigerant. If liquid backflow occurs, the liquid will not enter the scroll of the compressed part directly.

### Low-pressure shells

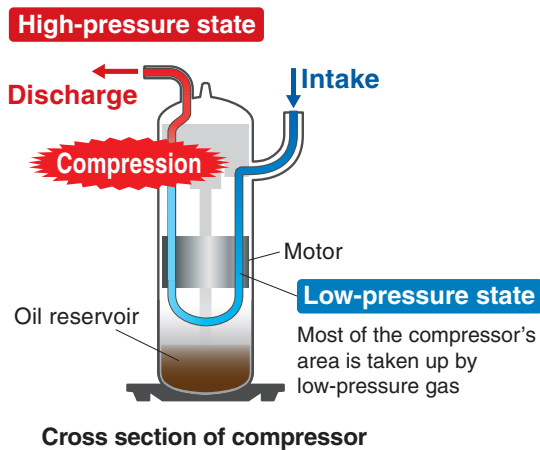

Most of the area in the compressor is taken up by the low-pressure gas. This prevents the motor and bearings from being heated up by the compressed high-pressure gas. The refrigerant is collected at the bottom of the shell to reduce the rate of compressor damage caused by liquid refrigerant compression.

### When liquid backflow has occurred

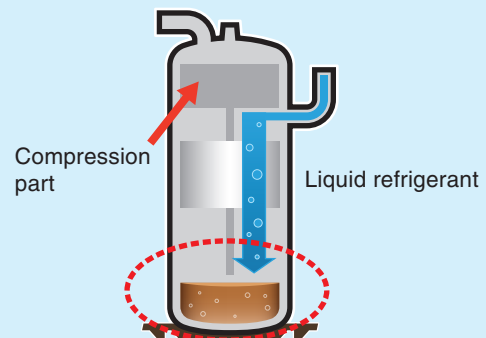

**Liquid refrigerant goes to bottom part firstly**

Liquid refrigerant doesn't go to compression part directly so that compressor itself is protected from malfunction due to liquid back.

### Accumulator for preventing liquid backflow



When the refrigerant is not completely evaporated by the evaporator, it may remain as a liquid, flowing back into the compressor and causing liquid compression, which poses the risk of serious damage to the compressor. To counter this problem, Mitsubishi Electric uses an accumulator placed between the evaporator and the compressor to separate the liquid refrigerant.

\* Adding too much refrigerant will cause excess refrigerant to accumulate in the accumulator, resulting in liquid back flow. Be sure to add only the proper amount of refrigerant.

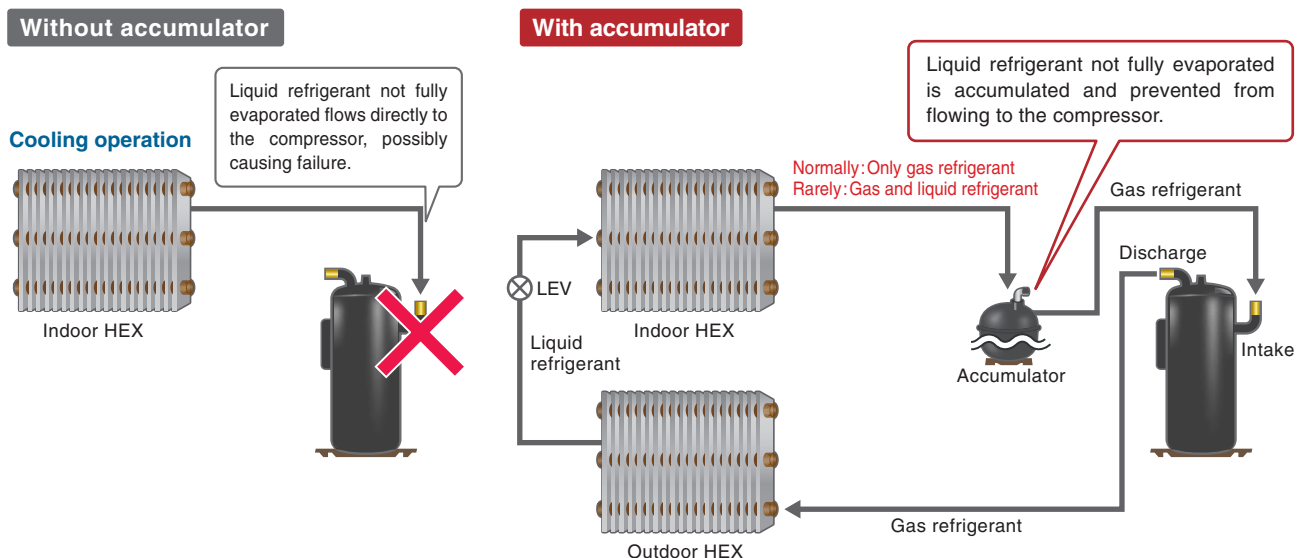

### Operation with one compressor up to 20HP.



Outdoor units can be operated by one compressor, which contributes to improve service with less refrigerant piping work and components.

#### 1 compressor model

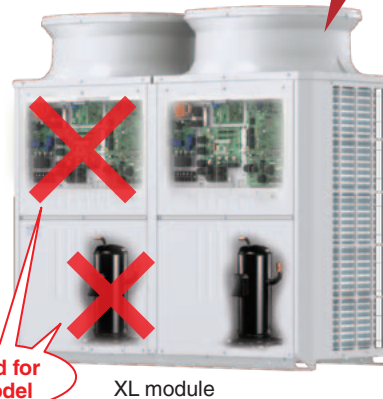

Lower number of required key parts reduces maintenance requirements

No need for our model

### Rotation control



With the combination model, the outdoor units operate alternately. This reduces the operating load and leads to a longer service life.

After operation for 2 hours or more, the next operation will be started from the outdoor unit "2." The unit to be started first is changed to equalize the operating time of the units.

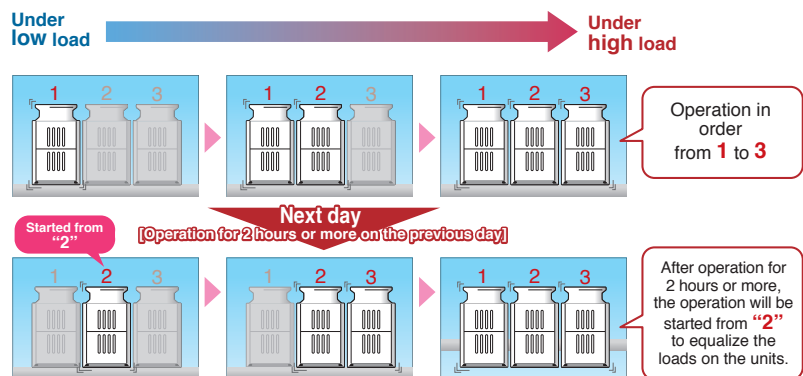

### Emergency operation mode



Emergency operation is possible with the indoor unit's remote control. With the combination model, if there is at least one module that can operate normally, the other outdoor unit temporarily performs emergency operation.

#### With emergency operation function

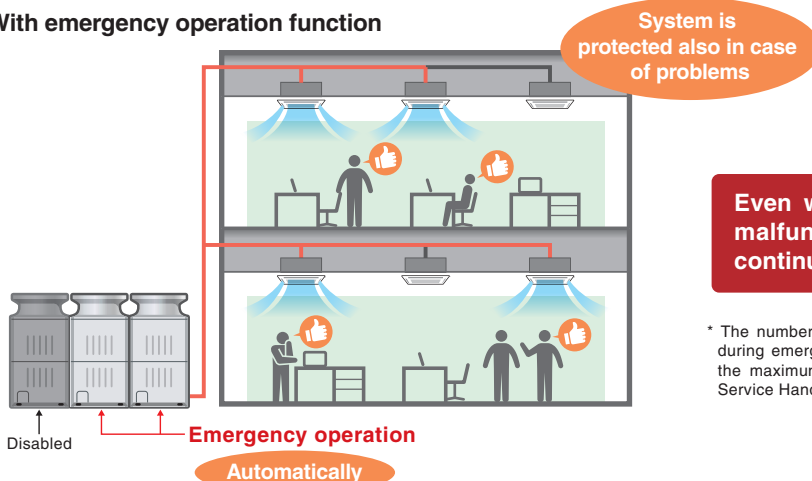

Even when one unit has fallen in a malfunction, other outdoor units continue to operate.

\* The number of indoor units that can continue to operate during emergency operation is limited. For information on the maximum total capacity of indoor units, refer to the Service Handbook for the outdoor unit.



# High reliability

## 2. Electric parts

### Allowable operating up to $\pm 10\%$ voltage range



Operation of this model is guaranteed even for voltages up to 10% more or less than the indicated allowable voltage.

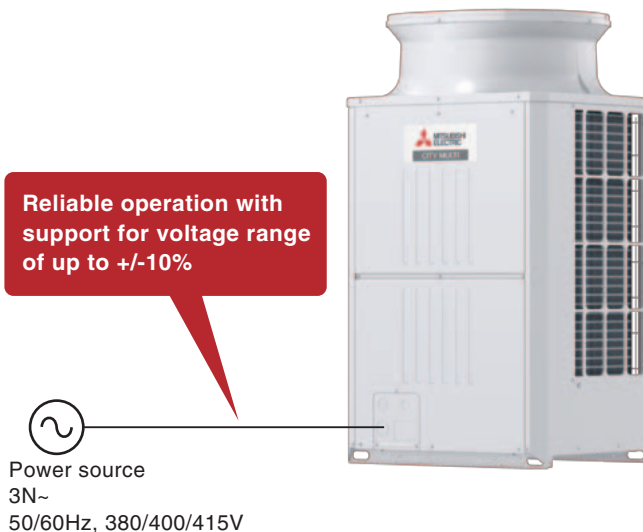

\* When used 380V, operation is guaranteed even for voltages of up to maximum +20%

### Naturally cooled PCB (Print circuit board)



PCBs (printed circuit boards) carry a large number of electronic components. When operation load increases, suitable cooling measures are required.

Mitsubishi Electric places PCBs in the natural air flow path which enables air cooling to maintain efficiency and improve reliability of each electronic component.

PCB is naturally cooled by air

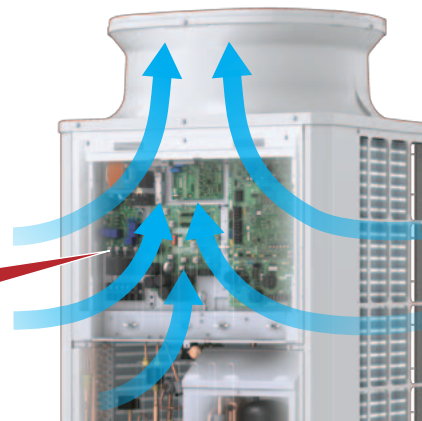

### Access from front panel



Electrical parts are concentrated in the upper part of the panel which can be opened for easy replacement of PCBs if required.

Because the compressor is located in the lower right when the panel is opened, the service technician can easily perform maintenance from the front.

Easy to access



\* Arrange a qualified technician for maintenance or service.

### 3. Corrosion resistance

Even in installation environments near coastal areas, Mitsubishi Electric products reduce the effects of corrosion due to salt damage by using a special coating designed for outdoor units.

\* Effectiveness varies depending on the installation location.

#### Film coating on PCB (Print circuit board) PUCY P PUCY EP PUHY P PUHY EP

The printed circuit boards are protected by a film coating of polyurethane that covers the entire board to ensure resistance against salt corrosion.

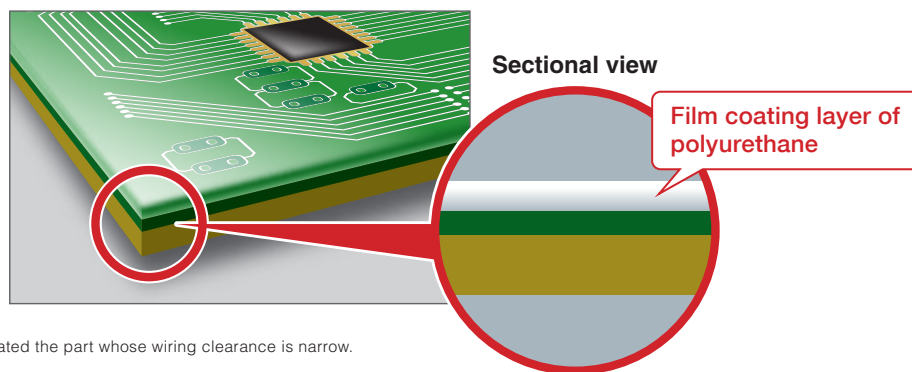

\* Standard model is only coated the part whose wiring clearance is narrow.

#### Polyester coated sheet PUCY P PUCY EP PUHY P PUHY EP

To prevent corrosion of the unit even in locations subject to the influence of sea breezes, the outdoor units are made with polyester coated steel sheets compliant with the JRA 9002 standard. The panel coating is used both on standard models and BS models, while BS models also include a thicker coating.

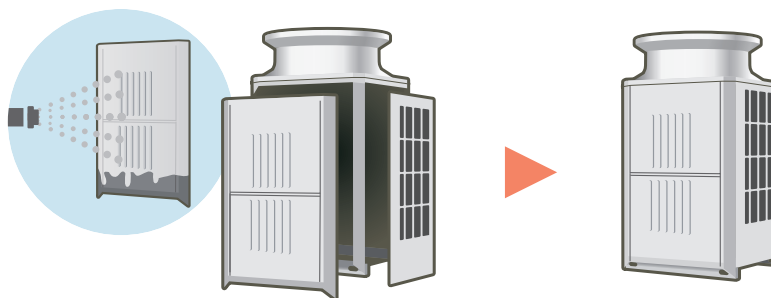

#### Fin treatment on heat exchanger PUCY P PUCY EP PUHY P PUHY EP

The anti-corrosion fin treatment on the heat exchanger is especially effective in urban environments where traffic pollutions can damage the aluminum fins, reducing the capacity and life expectancy of the unit. All YKD series feature this Fin treatment.

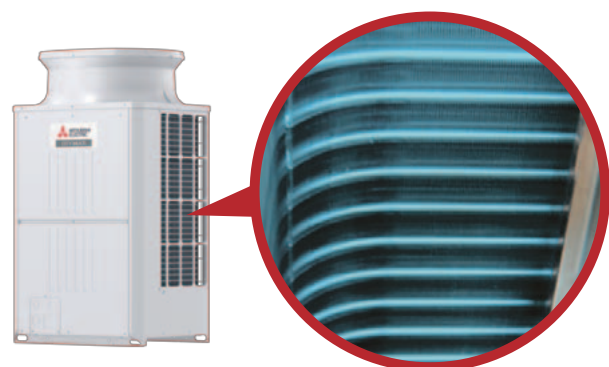

# High reliability

## 1. Operation support function

Without requiring any special settings or control steps, Mitsubishi Electric's original M-NET system enables other indoor units to continue operation even when one unit has stopped due to malfunction.

\* Support for PUMY and PQHY models available.

### With M-NET indoor/outdoor unit communication function (CITY MULTI)

Because Mitsubishi Electric's M-NET transmission line can also supply power, it is possible to close the LEV of indoor units that has caused problem through control command from outdoor unit. This eliminates the risk of condensation and enables the other units to keep working.

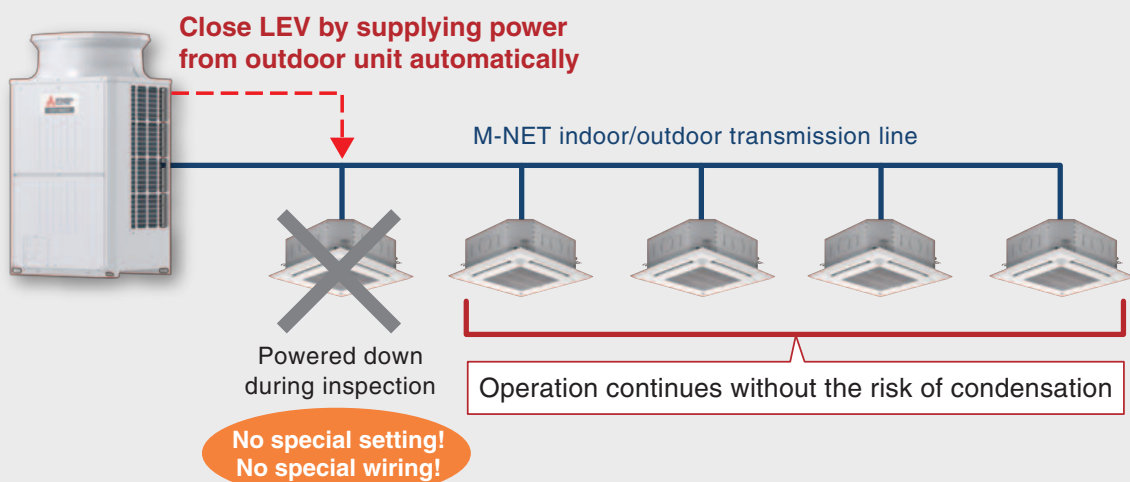

### For hotel application

Even if the system in one guest room cannot be used, air conditioning in other rooms does not need to be shut down, allowing business to continue.

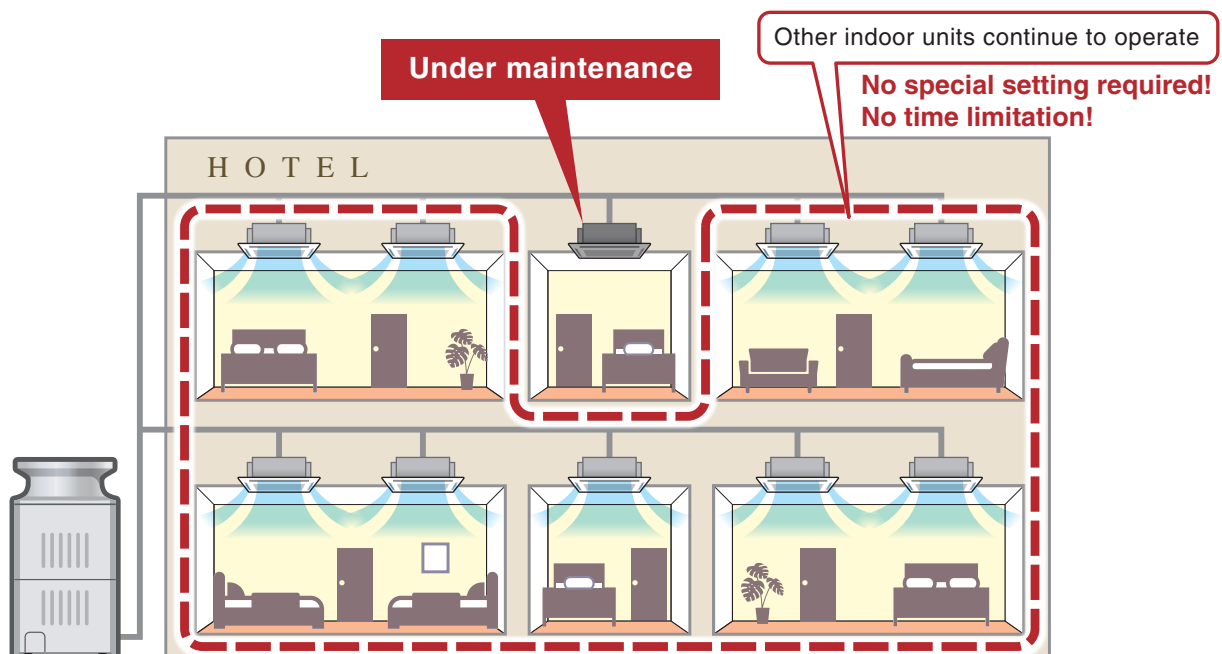

# High installation flexibility

## 1. Flexible wiring design

### Flexible M-NET design



The total wiring length of the original M-NET system connecting the CITY MULTI units of Mitsubishi Electric is unlimited. The system also supports multiple branching levels which greatly increases design flexibility for various buildings.

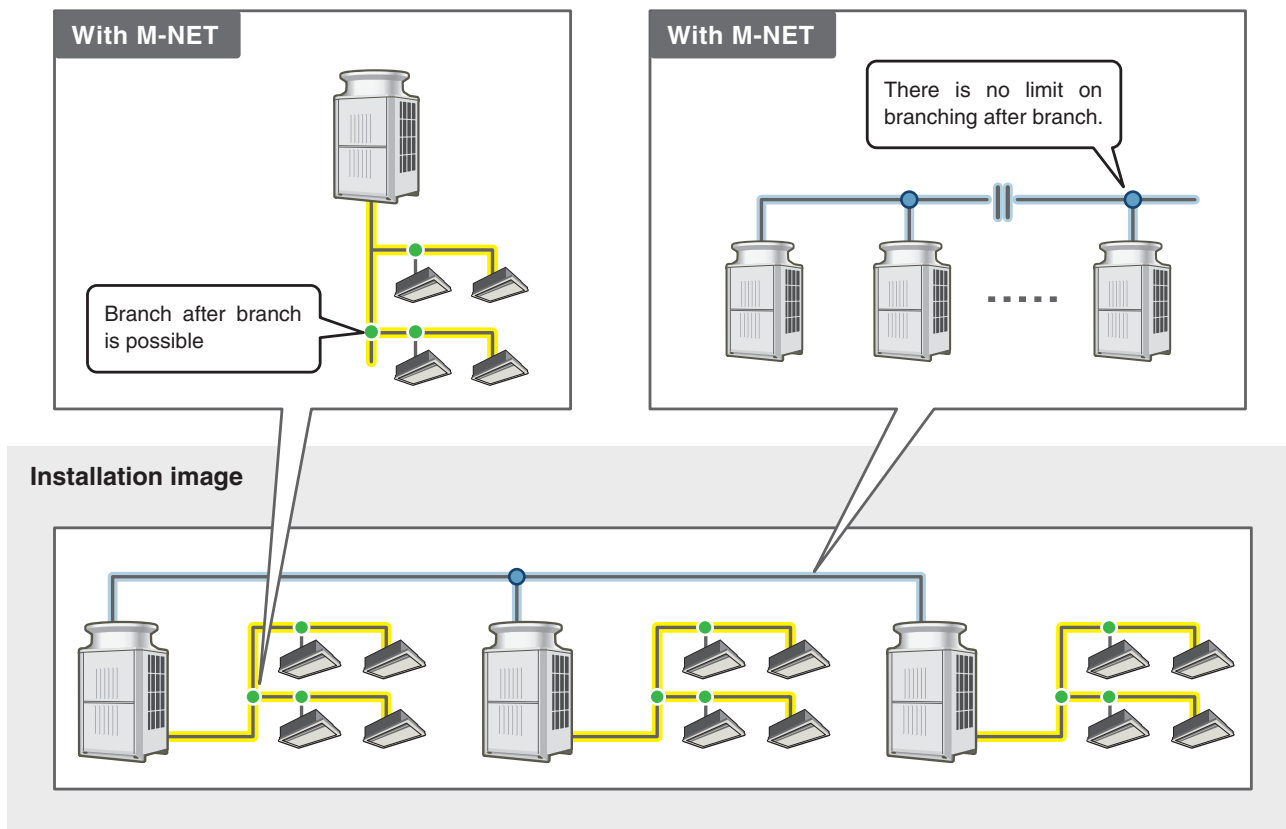

\* The maximum power-supply distance of M-NET communication is 200 meters, a booster unit is required over 200 meters. Regarding maximum distance to the farthest device, please refer to "Explanatory material for M-NET 1000 m."

## 2. Flexible external static pressure setting

### Selectable external static pressure of the outdoor unit



The static pressure specification of the outdoor unit can be selected (0, 30, 60 Pa). This facilitates installation of the unit on each floor of a high-rise building or on balconies.

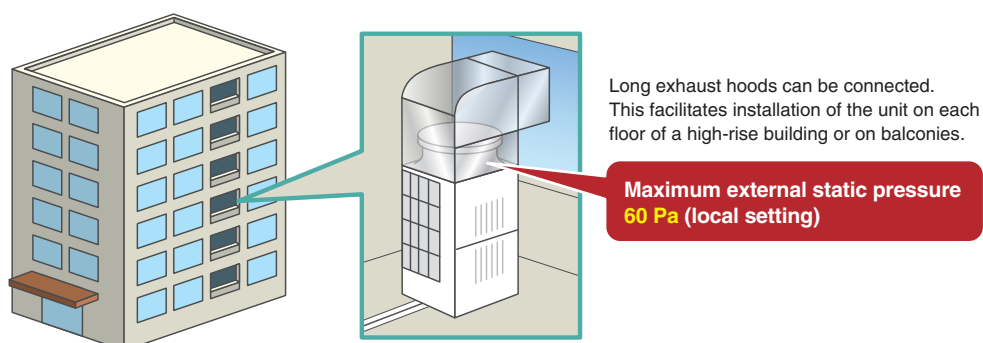



# High installation flexibility

## 3. Long piping length

Piping design also provides the flexibility to match the requirements of various buildings. With CITY MULTI, even large-scale building installations are no problem.

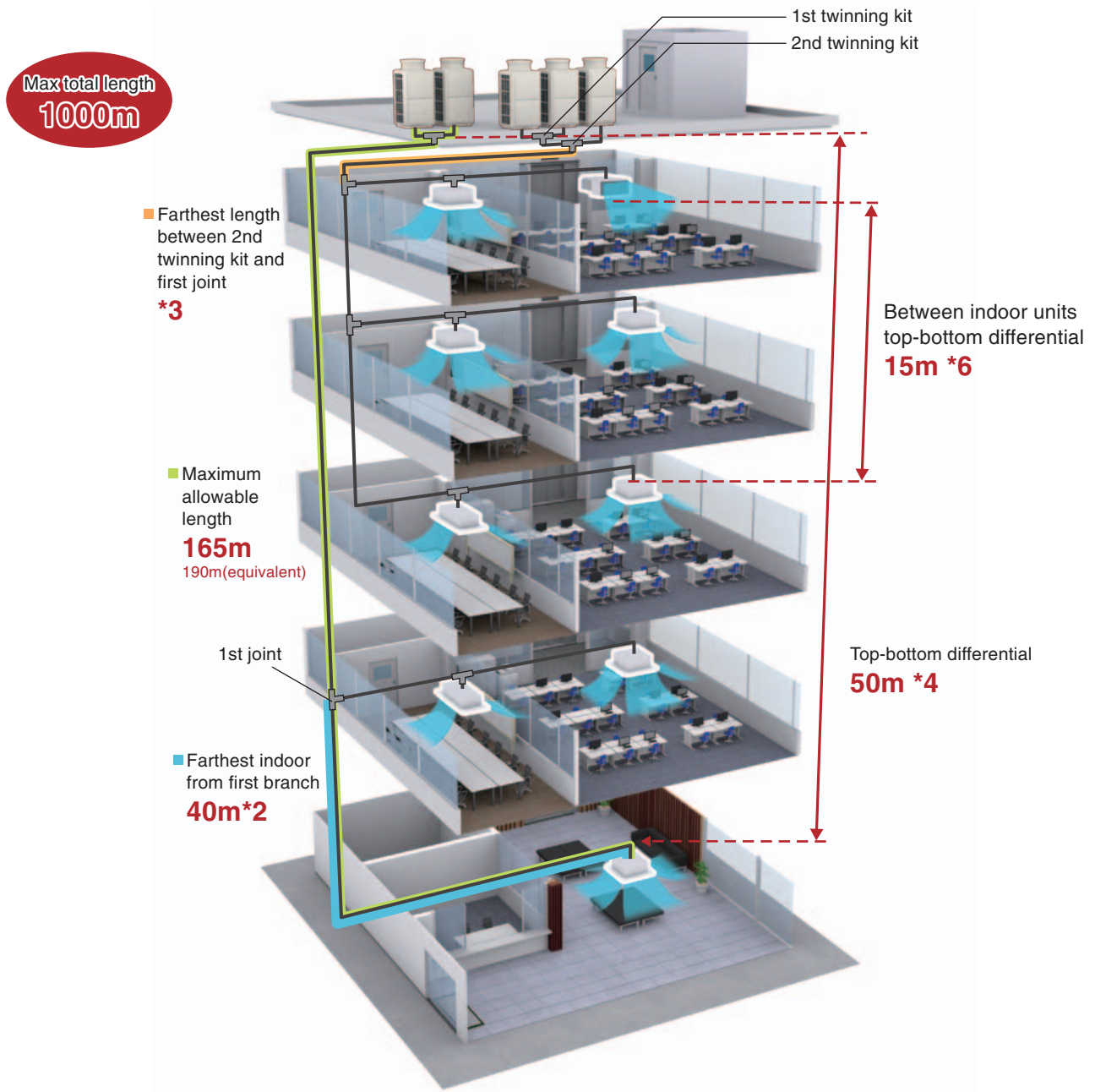

Refrigerant Piping Lengths	Maximum meters [feet]
Total length	1,000 [3,280]*1
Maximum allowable length	165 (190 equivalent) [541 (623)]
Farthest indoor from first branch	40 [131]*2
Farthest length between 2nd twinning kit and first joint	*3
Vertical differentials between units	Maximum meters [feet]
Indoor/outdoor (outdoor higher)	50 [164]*4
Indoor/outdoor (outdoor lower)	40 [131]*5
Indoor/indoor	15 [49]*6

\*1 The maximum total piping length in systems with model units P1400 through P1500 800 m [2625 ft.].  
 \*2 90m is available. When the piping length exceeds 40m, use one size larger liquid pipe starting with the section of piping where 40m is exceeded and all piping after that point.  
 [for PUCY-P-YKD(-BS) / PUCY-EP-YKD(-BS)]  
 \*3 In systems with model units P1400 through P1500, pipe length restrictions apply to the main pipes as follows:  
 P1400: 110 m [360 ft.] max.  
 P1450: 90 m [295 ft.] max.  
 P1500: 60 m [197 ft.] max.  
 \*4 Depending on the model and installation conditions, top-bottom differential 90m [295ft]. For more detailed information, please contact your nearest sales office or distributor.  
 \*5 4 m [13 ft.] or less in cooling at outdoor temperature 10°C [50°F] or lower for heat pump series.  
 \*6 30m is available. If the height difference between indoor units exceeds 15 m [49 ft.] (but does not exceed 30 m [98 ft.]), use pipes that are one size larger for indoor unit liquid pipes.  
 [for PUCY-P-YKD(-BS) / PUCY-EP-YKD(-BS) / PUHY-(E)P-YKD(-BS)]

# Other useful information

## Low noise mode (night mode) PUCY P PUCY EP PUHY P PUHY EP

This mode reduces noise by limiting the compressor frequency and the number of rotations made by the outdoor fan.

The user can select their preferred level.

- \* Cooling/heating capacity drops significantly during low-noise mode operation. During cooling operation, please use this mode under a situation which there is a substantial capacity such as at night.
- \* This function can be set by change of dip switch.



### PUHY-P200YKD

standard 57dB  
↓ 13 dB down  
 Low noise mode 44dB\*

\* Operation noise may increase due to the installation environment or the operation status.

- Increased adaptability and model selection range for buildings where low noise is essential
- Low noise mode can also be selected after delivery using DIP switches

**Changing low noise mode to suit the installation location allows adaptation to the surrounding environment.**

Outdoor unit installed on roof operates in standard mode



Outdoor unit installed on balconies operate in low noise mode



AE-200E

Low noise mode can be scheduled from the Web browser of AE-200E by connecting the PC.

## System changeover (for heat pump) PUHY P PUHY EP

### Normal switching between cooling and heating

With CITY MULTI's switchable cooling/heating models, in order to switch from cooling to heating, the operation mode of all indoor units performing cooling operation needs to be manually switched.

### Using system-changeover to switch between cooling and heating

Depending on the dip switch settings, all indoor units can automatically switch their operation mode according to the operation mode of a specific indoor unit (the unit with the smallest M-NET address). Operation can be automatically switched between cooling and heating according to the temperature difference between the preset temperature on a specific indoor unit and the room temperature.

\* Please avoid the indoor unit with the smallest number address to group with other indoor units.

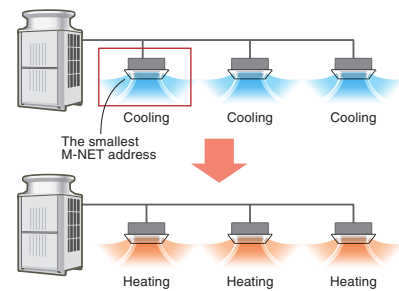

### Suitable situations

When both cooling and heating operations are required in a single day due to an extreme differences between the hottest and coldest parts of the day.

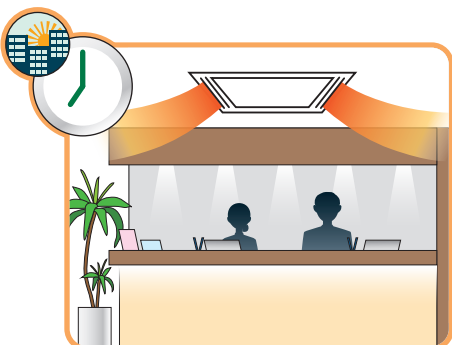

When the temperature sensor detects a certain amount of differential between the room temperature and the set temperature, the operation of all indoor units in the system is switched from heating to cooling.

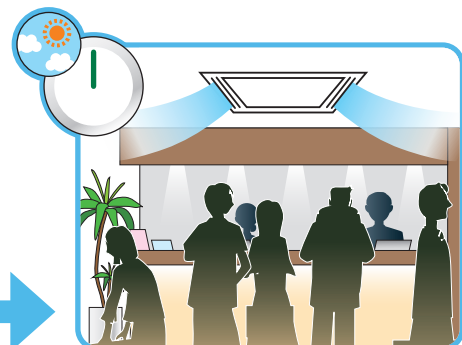

\* The operation of all indoor units connected to the same outdoor unit is switched.

OUTDOOR UNIT

**YKD-series - Cooling-only**

**PUCY-P YKD (-BS)**



**Specifications**

Model		PUCY-P200YKD (-BS)	PUCY-P250YKD (-BS)	PUCY-P300YKD (-BS)	PUCY-P350YKD (-BS)	
Power source		3-phase 4-wire 380-400-415 V 50/60 Hz	3-phase 4-wire 380-400-415 V 50/60 Hz	3-phase 4-wire 380-400-415 V 50/60 Hz	3-phase 4-wire 380-400-415 V 50/60 Hz	
Cooling capacity (Nominal)	*1 kW	22.4	28.0	33.5	40.0	
	BTU/h	76,400	95,500	114,300	136,500	
	Power input kW	4.66	5.95	7.82	9.66	
	Current input A	7.8-7.4-7.2	10.0-9.5-9.1	13.2-12.5-12.0	16.3-15.4-14.9	
	EER kW/kW	4.80	4.70	4.28	4.14	
Temp. range of cooling	Indoor W.B.	15.0~24.0 °C (59~75 °F)	15.0~24.0 °C (59~75 °F)	15.0~24.0 °C (59~75 °F)	15.0~24.0 °C (59~75 °F)	
	Outdoor D.B.	10.0~52.0 °C (50~126 °F)	10.0~52.0 °C (50~126 °F)	10.0~52.0 °C (50~126 °F)	10.0~52.0 °C (50~126 °F)	
Indoor unit connectable	Total capacity	50~130% of outdoor unit capacity	50~130% of outdoor unit capacity	50~130% of outdoor unit capacity	50~130% of outdoor unit capacity	
	Model/Quantity	P15~P250/1~17	P15~P250/1~21	P15~P300/1~26	P15~P300/1~30	
Sound pressure level (measured in anechoic room)	dB <A>	57	58	61	61	
Refrigerant piping diameter	Liquid pipe mm (in.)	9.52 (3/8) Brazed	9.52 (3/8) Brazed (12.7 (1/2) Brazed, farthest length >= 90 m)	9.52 (3/8) Brazed (12.7 (1/2) Brazed, farthest length >= 40 m)	12.7 (1/2) Brazed	
	Gas pipe mm (in.)	22.2 (7/8) Brazed	22.2 (7/8) Brazed	22.2 (7/8) Brazed	28.58 (1-1/8) Brazed	
Fan	Type x Quantity	Propeller fan x 1				
	Air flow rate	m <sup>3</sup> /min	175	175	175	210
		L/s	2,917	2,917	2,917	3,500
		cfm	6,179	6,179	6,179	7,415
	Control, Driving mechanism	Inverter-control, Direct-driven by motor				
	Motor output kW	0.92 x 1				
*2 External static press.	0 Pa (0 mmH <sub>2</sub> O)					
Compressor	Type	Inverter scroll hermetic compressor				
	Starting method	Inverter				
	Motor output kW	5.5	6.9	8.1	10.4	
	Case heater kW	-				
External finish	Pre-coated galvanized steel sheets (+powder coating for -BS type) <MUNSELL 3Y 7.8/1.1 or similar>					
External dimension H x W x D	mm	1,650 x 920 x 740	1,650 x 920 x 740	1,650 x 920 x 740	1,650 x 1,220 x 740	
	in.	65 x 36-1/4 x 29-3/16	65 x 36-1/4 x 29-3/16	65 x 36-1/4 x 29-3/16	65 x 48-1/16 x 29-3/16	
Protection devices	High pressure protection	High pressure sensor, High pressure switch at 4.15 MPa (601 psi)				
	Inverter circuit (COMP./FAN)	Over-heat protection, Over-current protection				
Refrigerant	Type x original charge	R410A x 5.5 kg (13 lbs)				
Net weight	kg (lbs)	174 (384)	183 (404)	200 (441)	236 (521)	
Heat exchanger		Salt-resistant cross fin & copper tube				
Optional parts		Joint: CMY-Y102SS/LS-G2 Header: CMY-Y104/108/1010-G	Joint: CMY-Y102SS/LS-G2 Header: CMY-Y104/108/1010-G	Joint: CMY-Y102SS/LS-G2 Header: CMY-Y104/108/1010-G	Joint: CMY-Y102SS/LS-G2 Header: CMY-Y104/108/1010-G	

**Notes:**

\*1 Nominal cooling conditions (subject to JIS B8615-2)

	Indoor	Outdoor	Pipe length	Level difference
Cooling	27 °CD.B./19 °CW.B. (81 °FD.B./66 °FW.B.)	35 °CD.B. (95 °FD.B.)	7.5 m (24-9/16 ft.)	0 m (0 ft.)

\*2 External static pressure option is available (30Pa, 60Pa / 3.1mmH<sub>2</sub>O, 6.1mmH<sub>2</sub>O).

\*Due to continuing improvement, above specifications may be subject to change without notice.

OUTDOOR UNIT

YKD-series - Cooling-only

PUCY-P YKD (-BS)



Advantages of CITY MULTI

Outdoor/Heat source unit

Indoor unit

Remote Controller

Lossnay

Installation information

## Specifications

Model		PUCY-P400YKD (-BS)	PUCY-P450YKD (-BS)	PUCY-P500YKD (-BS)
Power source		3-phase 4-wire 380-400-415 V 50/60 Hz		
Cooling capacity (Nominal)		44.0	48.0	56.0
		BTU/h	150,100	163,800
Power input		12.42	14.32	16.51
Current input		20.9-19.9-19.1	24.1-22.9-22.1	27.8-26.4-25.5
EER		3.54	3.35	3.39
Temp. range of cooling		Indoor W.B. 15.0~24.0 °C (59~75 °F)	15.0~24.0 °C (59~75 °F)	15.0~24.0 °C (59~75 °F)
		Outdoor D.B. 10.0~52.0 °C (50~126 °F)	10.0~52.0 °C (50~126 °F)	10.0~52.0 °C (50~126 °F)
Indoor unit connectable		Total capacity 50~130% of outdoor unit capacity	50~130% of outdoor unit capacity	50~130% of outdoor unit capacity
		Model/Quantity P15~P400/1~34	P15~P400/1~39	P15~P500/1~43
Sound pressure level (measured in anechoic room)		dB <A>		
		63	63	65
Refrigerant piping diameter		Liquid pipe mm (in.) 12.7 (1/2) Brazed	15.88 (5/8) Brazed	15.88 (5/8) Brazed
		Gas pipe mm (in.) 28.58 (1-1/8) Brazed	28.58 (1-1/8) Brazed	28.58 (1-1/8) Brazed
Fan		Type x Quantity Propeller fan x 1	Propeller fan x 1	Propeller fan x 2
Air flow rate		m <sup>3</sup> /min 210	210	320
		L/s 3,500	3,500	5,333
		cfm 7,415	7,415	11,299
Control, Driving mechanism		Inverter-control, Direct-driven by motor		
Motor output		0.92 x 1	0.92 x 1	0.92 x 2
*2 External static press.		0 Pa (0 mmH <sub>2</sub> O)		
Compressor		Type Inverter scroll hermetic compressor	Inverter scroll hermetic compressor	Inverter scroll hermetic compressor
		Starting method Inverter	Inverter	Inverter
Motor output		10.8	12.4	13.3
Case heater		kW -		
External finish		Pre-coated galvanized steel sheets (+powder coating for -BS type) <MUNSELL 3Y 7.8/1.1 or similar>		
External dimension H x W x D		mm 1,650 x 1,220 x 740	1,650 x 1,220 x 740	1,650 x 1,750 x 740
		in. 65 x 48-1/16 x 29-3/16	65 x 48-1/16 x 29-3/16	65 x 68-15/16 x 29-3/16
Protection devices		High pressure protection High pressure sensor, High pressure switch at 4.15 MPa (601 psi)	High pressure sensor, High pressure switch at 4.15 MPa (601 psi)	High pressure sensor, High pressure switch at 4.15 MPa (601 psi)
		Inverter circuit (COMP./FAN) Over-heat protection, Over-current protection	Over-heat protection, Over-current protection	Over-heat protection, Over-current protection
Refrigerant		Type x original charge R410A x 11.5 kg (26 lbs)	R410A x 11.5 kg (26 lbs)	R410A x 11.8 kg (27 lbs)
Net weight		236 (521)	236 (521)	304 (671)
Heat exchanger		Salt-resistant cross fin & copper tube		
Optional parts		Joint: CMY-Y102SS/LS-G2, CMY-Y202S-G2 Header: CMY-Y104/108/1010-G	Joint: CMY-Y102SS/LS-G2, CMY-Y202S-G2 Header: CMY-Y104/108/1010-G	Joint: CMY-Y102SS/LS-G2, CMY-Y202S-G2 Header: CMY-Y104/108/1010-G

## Notes:

\*1 Nominal cooling conditions (subject to JIS B8615-2)

	Indoor	Outdoor	Pipe length	Level difference
Cooling	27 °CD.B./19 °CW.B. (81 °FD.B./66 °FW.B.)	35 °CD.B. (95 °FD.B.)	7.5 m (24-9/16 ft.)	0 m (0 ft.)

\*2 External static pressure option is available (30Pa, 60Pa / 3.1mmH<sub>2</sub>O, 6.1mmH<sub>2</sub>O).

\*Due to continuing improvement, above specifications may be subject to change without notice.



OUTDOOR UNIT

**YKD-series - Cooling-only**

**PUCY-P YSKD (-BS)**



**Specifications**

Model		PUCY-P550YSKD (-BS)	PUCY-P600YSKD (-BS)	PUCY-P650YSKD (-BS)
Power source		3-phase 4-wire 380-400-415 V 50/60 Hz	3-phase 4-wire 380-400-415 V 50/60 Hz	3-phase 4-wire 380-400-415 V 50/60 Hz
Cooling capacity (Nominal)	*1 kW	61.5	68.0	72.0
	BTU/h	209,800	232,000	245,700
	Power input kW	14.04	15.34	17.73
	Current input A	23.7-22.5-21.7	25.8-24.6-23.7	29.9-28.4-27.4
	EER kW/kW	4.38	4.43	4.06
Temp. range of cooling	Indoor W.B.	15.0~24.0 °C (59~75 °F)	15.0~24.0 °C (59~75 °F)	15.0~24.0 °C (59~75 °F)
	Outdoor D.B.	10.0~52.0 °C (50~126 °F)	10.0~52.0 °C (50~126 °F)	10.0~52.0 °C (50~126 °F)
Indoor unit connectable	Total capacity	50~130% of outdoor unit capacity	50~130% of outdoor unit capacity	50~130% of outdoor unit capacity
	Model/Quantity	P15~P500/1~47	P15~P600/1~50	P15~P600/1~50
Sound pressure level (measured in anechoic room)	dB <A>	63	63	64.5
Refrigerant piping diameter	Liquid pipe mm (in.)	15.88 (5/8) Brazed	15.88 (5/8) Brazed	15.88 (5/8) Brazed
	Gas pipe mm (in.)	28.58 (1-1/8) Brazed	28.58 (1-1/8) Brazed	28.58 (1-1/8) Brazed

**Set Model**

Model		PUCY-P250YKD (-BS)	PUCY-P300YKD (-BS)	PUCY-P250YKD (-BS)	PUCY-P350YKD (-BS)	PUCY-P250YKD (-BS)	PUCY-P400YKD (-BS)	
Fan	Type x Quantity	Propeller fan x 1	Propeller fan x 1	Propeller fan x 1	Propeller fan x 1	Propeller fan x 1	Propeller fan x 1	
	Air flow rate	m <sup>3</sup> /min	175	175	175	210	175	210
		L/s	2,917	2,917	2,917	3,500	2,917	3,500
		cfm	6,179	6,179	6,179	7,415	6,179	7,415
	Control, Driving mechanism	Inverter-control, Direct-driven by motor		Inverter-control, Direct-driven by motor		Inverter-control, Direct-driven by motor		
*2 Motor output	kW	0.92 x 1	0.92 x 1	0.92 x 1	0.92 x 1	0.92 x 1	0.92 x 1	
Compressor	External static press.	0 Pa (0 mmH <sub>2</sub> O)	0 Pa (0 mmH <sub>2</sub> O)	0 Pa (0 mmH <sub>2</sub> O)	0 Pa (0 mmH <sub>2</sub> O)	0 Pa (0 mmH <sub>2</sub> O)	0 Pa (0 mmH <sub>2</sub> O)	
	Type	Inverter scroll hermetic compressor		Inverter scroll hermetic compressor		Inverter scroll hermetic compressor		
	Starting method	Inverter	Inverter	Inverter	Inverter	Inverter	Inverter	
	Motor output	kW	6.9	8.1	6.9	10.4	6.9	10.8
External finish	Case heater	kW	-	-	-	-	-	
		Pre-coated galvanized steel sheets (+powder coating for -BS type) <MUNSELL 3Y 7.8/1.1 or similar>		Pre-coated galvanized steel sheets (+powder coating for -BS type) <MUNSELL 3Y 7.8/1.1 or similar>		Pre-coated galvanized steel sheets (+powder coating for -BS type) <MUNSELL 3Y 7.8/1.1 or similar>		
External dimension H x W x D	mm	1,650 x 920 x 740	1,650 x 920 x 740	1,650 x 920 x 740	1,650 x 1,220 x 740	1,650 x 920 x 740	1,650 x 1,220 x 740	
	in.	65 x 36-1/4 x 29-3/16	65 x 36-1/4 x 29-3/16	65 x 36-1/4 x 29-3/16	65 x 48-1/16 x 29-3/16	65 x 36-1/4 x 29-3/16	65 x 48-1/16 x 29-3/16	
Protection devices	High pressure protection	High pressure sensor, High pressure switch at 4.15 MPa (601 psi)		High pressure sensor, High pressure switch at 4.15 MPa (601 psi)		High pressure sensor, High pressure switch at 4.15 MPa (601 psi)		
	Inverter circuit (COMP./FAN)	Over-heat protection, Over-current protection		Over-heat protection, Over-current protection		Over-heat protection, Over-current protection		
Refrigerant	Type x original charge	R410A x 6.5 kg (15 lbs)	R410A x 6.5 kg (15 lbs)	R410A x 6.5 kg (15 lbs)	R410A x 11.5 kg (26 lbs)	R410A x 6.5 kg (15 lbs)	R410A x 11.5 kg (26 lbs)	
Net weight	kg (lbs)	183 (404)	200 (441)	183 (404)	236 (521)	183 (404)	236 (521)	
Heat exchanger		Salt-resistant cross fin & copper tube		Salt-resistant cross fin & copper tube		Salt-resistant cross fin & copper tube		
Pipe between unit and distributor	Liquid pipe	mm (in.)	9.52 (3/8) Brazed	12.7 (1/2) Brazed	9.52 (3/8) Brazed	12.7 (1/2) Brazed	9.52 (3/8) Brazed	15.88 (5/8) Brazed
	Gas pipe	mm (in.)	22.2 (7/8) Brazed	22.2 (7/8) Brazed	22.2 (7/8) Brazed	28.58 (1-1/8) Brazed	22.2 (7/8) Brazed	28.58 (1-1/8) Brazed
Optional parts		Outdoor Twinning kit: CMY-Y100VBK3 Joint: CMY-Y102SS/LS-G2, CMY-Y202/302S-G2 Header: CMY-Y104/108/1010-G		Outdoor Twinning kit: CMY-Y100VBK3 Joint: CMY-Y102SS/LS-G2, CMY-Y202/302S-G2 Header: CMY-Y104/108/1010-G		Outdoor Twinning kit: CMY-Y100VBK3 Joint: CMY-Y102SS/LS-G2, CMY-Y202/302S-G2 Header: CMY-Y104/108/1010-G		

**Notes:**

\*1 Nominal cooling conditions (subject to JIS B8615-2)

	Indoor	Outdoor	Pipe length	Level difference
Cooling	27 °CD.B./19 °CW.B. (81 °FD.B./66 °FW.B.)	35 °CD.B. (95 °FD.B.)	7.5 m (24-9/16 ft.)	0 m (0 ft.)

\*2 External static pressure option is available (30Pa, 60Pa / 3.1mmH<sub>2</sub>O, 6.1mmH<sub>2</sub>O).

\*Due to continuing improvement, above specifications may be subject to change without notice.

## OUTDOOR UNIT

## YKD-series - Cooling-only

## PUCY-P YSKD (-BS)



## Specifications

Model	PUCY-P700YSKD (-BS)		PUCY-P750YSKD (-BS)		PUCY-P800YSKD (-BS)			
Power source	3-phase 4-wire 380-400-415 V 50/60 Hz		3-phase 4-wire 380-400-415 V 50/60 Hz		3-phase 4-wire 380-400-415 V 50/60 Hz			
Cooling capacity (Nominal)	*1	kW	76.0		81.5			
		BTU/h	259,300		278,100			
		Power input kW	19.24		21.79			
		Current input A	32.4-30.8-29.7		36.7-34.9-33.6			
		EER	3.95		3.74			
Temp. range of cooling	Indoor	W.B.	15.0~24.0 °C (59~75 °F)		15.0~24.0 °C (59~75 °F)			
	Outdoor	D.B.	10.0~52.0 °C (50~126 °F)		10.0~52.0 °C (50~126 °F)			
Indoor unit connectable	Total capacity	50~130% of outdoor unit capacity		50~130% of outdoor unit capacity		50~130% of outdoor unit capacity		
	Model/Quantity	P15~P600/1~50		P15~P600/1~50		P15~P600/1~50		
Sound pressure level (measured in anechoic room)	dB <A>	64.5		65.5		66		
Refrigerant piping diameter	Liquid pipe	mm (in.)	19.05 (3/4) Brazed		19.05 (3/4) Brazed		19.05 (3/4) Brazed	
	Gas pipe	mm (in.)	34.93 (1-3/8) Brazed		34.93 (1-3/8) Brazed		34.93 (1-3/8) Brazed	

## Set Model

Model	PUCY-P250YKD (-BS)		PUCY-P450YKD (-BS)		PUCY-P300YKD (-BS)		PUCY-P450YKD (-BS)		PUCY-P400YKD (-BS)		PUCY-P400YKD (-BS)			
Fan	Type x Quantity	Propeller fan x 1		Propeller fan x 1		Propeller fan x 1		Propeller fan x 1		Propeller fan x 1		Propeller fan x 1		
	Air flow rate	m <sup>3</sup> /min	175		210		175		210		210		210	
		L/s	2,917		3,500		2,917		3,500		3,500		3,500	
		cfm	6,179		7,415		6,179		7,415		7,415		7,415	
	Control, Driving mechanism	Inverter-control, Direct-driven by motor				Inverter-control, Direct-driven by motor				Inverter-control, Direct-driven by motor				
Compressor	*2	Motor output kW	0.92 x 1		0.92 x 1		0.92 x 1		0.92 x 1		0.92 x 1		0.92 x 1	
		External static press.	0 Pa (0 mmH <sub>2</sub> O)		0 Pa (0 mmH <sub>2</sub> O)		0 Pa (0 mmH <sub>2</sub> O)		0 Pa (0 mmH <sub>2</sub> O)		0 Pa (0 mmH <sub>2</sub> O)		0 Pa (0 mmH <sub>2</sub> O)	
		Type	Inverter scroll hermetic compressor				Inverter scroll hermetic compressor				Inverter scroll hermetic compressor			
External finish	Starting method	Inverter		Inverter		Inverter		Inverter		Inverter		Inverter		
	Motor output kW	6.9		12.4		8.1		12.4		10.8		10.8		
	Case heater	-		-		-		-		-		-		
External dimension H x W x D	mm	1,650 x 920 x 740		1,650 x 1,220 x 740		1,650 x 920 x 740		1,650 x 1,220 x 740		1,650 x 1,220 x 740		1,650 x 1,220 x 740		
Protection devices	High pressure protection	High pressure sensor, High pressure switch at 4.15 MPa (601 psi)		High pressure sensor, High pressure switch at 4.15 MPa (601 psi)		High pressure sensor, High pressure switch at 4.15 MPa (601 psi)		High pressure sensor, High pressure switch at 4.15 MPa (601 psi)		High pressure sensor, High pressure switch at 4.15 MPa (601 psi)		High pressure sensor, High pressure switch at 4.15 MPa (601 psi)		
		Inverter circuit (COMP./FAN)		Over-heat protection, Over-current protection		Over-heat protection, Over-current protection		Over-heat protection, Over-current protection		Over-heat protection, Over-current protection		Over-heat protection, Over-current protection		
	Refrigerant	Type x original charge	R410A x 6.5 kg (15 lbs)	R410A x 11.5 kg (26 lbs)	R410A x 6.5 kg (15 lbs)	R410A x 11.5 kg (26 lbs)	R410A x 6.5 kg (15 lbs)	R410A x 11.5 kg (26 lbs)	R410A x 11.5 kg (26 lbs)	R410A x 11.5 kg (26 lbs)	R410A x 11.5 kg (26 lbs)	R410A x 11.5 kg (26 lbs)		
Net weight	kg (lbs)	183 (404)		236 (521)		200 (441)		236 (521)		236 (521)		236 (521)		
Heat exchanger	Salt-resistant cross fin & copper tube				Salt-resistant cross fin & copper tube				Salt-resistant cross fin & copper tube					
Pipe between unit and distributor	Liquid pipe	mm (in.)	9.52 (3/8) Brazed		15.88 (5/8) Brazed		12.7 (1/2) Brazed		15.88 (5/8) Brazed		15.88 (5/8) Brazed		15.88 (5/8) Brazed	
	Gas pipe	mm (in.)	22.2 (7/8) Brazed		28.58 (1-1/8) Brazed		22.2 (7/8) Brazed		28.58 (1-1/8) Brazed		28.58 (1-1/8) Brazed		28.58 (1-1/8) Brazed	
Optional parts	Outdoor Twinning kit: CMY-Y200VBK2 Joint: CMY-Y102SS/LS-G2, CMY-Y202/302S-G2 Header: CMY-Y104/108/1010-G				Outdoor Twinning kit: CMY-Y200VBK2 Joint: CMY-Y102SS/LS-G2, CMY-Y202/302S-G2 Header: CMY-Y104/108/1010-G				Outdoor Twinning kit: CMY-Y200VBK2 Joint: CMY-Y102SS/LS-G2, CMY-Y202/302S-G2 Header: CMY-Y104/108/1010-G					

## Notes:

\*1 Nominal cooling conditions (subject to JIS B8615-2)

	Indoor	Outdoor	Pipe length	Level difference
Cooling	27 °CD.B./19 °CW.B. (81 °FD.B./66 °FW.B.)	35 °CD.B. (95 °FD.B.)	7.5 m (24-9/16 ft.)	0 m (0 ft.)

\*2 External static pressure option is available (30Pa, 60Pa / 3.1mmH<sub>2</sub>O, 6.1mmH<sub>2</sub>O).

\*Due to continuing improvement, above specifications may be subject to change without notice.

OUTDOOR UNIT

**YKD-series - Cooling-only**

**PUCY-P YSKD (-BS)**



**Specifications**

Model		PUCY-P850YSKD (-BS)	PUCY-P900YSKD (-BS)	PUCY-P950YSKD (-BS)
Power source		3-phase 4-wire 380-400-415 V 50/60 Hz	3-phase 4-wire 380-400-415 V 50/60 Hz	3-phase 4-wire 380-400-415 V 50/60 Hz
Cooling capacity (Nominal)	*1 kW	92.0	96.0	104.0
	BTU/h	313,900	327,600	354,800
	Power input kW	26.97	29.00	31.51
	Current input A	45.5-43.2-41.6	48.9-46.5-44.8	53.1-50.5-48.7
	EER	3.41	3.31	3.30
Temp. range of cooling	Indoor W.B.	15.0~24.0 °C (59~75 °F)	15.0~24.0 °C (59~75 °F)	15.0~24.0 °C (59~75 °F)
	Outdoor D.B.	10.0~52.0 °C (50~126 °F)	10.0~52.0 °C (50~126 °F)	10.0~52.0 °C (50~126 °F)
Indoor unit connectable	Total capacity	50~130% of outdoor unit capacity	50~130% of outdoor unit capacity	50~130% of outdoor unit capacity
	Model/Quantity	P15~P600/1~50	P15~P600/1~50	P15~P600/1~50
Sound pressure level (measured in anechoic room)	dB <A>	66	66	67.5
Refrigerant piping diameter	Liquid pipe mm (in.)	19.05 (3/4) Brazed	19.05 (3/4) Brazed	19.05 (3/4) Brazed
	Gas pipe mm (in.)	41.28 (1-5/8) Brazed	41.28 (1-5/8) Brazed	41.28 (1-5/8) Brazed

**Set Model**

Model		PUCY-P400YKD (-BS)	PUCY-P450YKD (-BS)	PUCY-P450YKD (-BS)	PUCY-P450YKD (-BS)	PUCY-P450YKD (-BS)	PUCY-P500YKD (-BS)	
Fan	Type x Quantity	Propeller fan x 1	Propeller fan x 1	Propeller fan x 1	Propeller fan x 1	Propeller fan x 1	Propeller fan x 2	
	Air flow rate	m <sup>3</sup> /min	210	210	210	210	210	320
		L/s	3,500	3,500	3,500	3,500	3,500	5,333
		cfm	7,415	7,415	7,415	7,415	7,415	11,299
	Control, Driving mechanism	Inverter-control, Direct-driven by motor		Inverter-control, Direct-driven by motor		Inverter-control, Direct-driven by motor		
*2 Motor output	kW	0.92 x 1	0.92 x 1	0.92 x 1	0.92 x 1	0.92 x 1	0.92 x 2	
External static press.		0 Pa (0 mmH <sub>2</sub> O)	0 Pa (0 mmH <sub>2</sub> O)	0 Pa (0 mmH <sub>2</sub> O)	0 Pa (0 mmH <sub>2</sub> O)	0 Pa (0 mmH <sub>2</sub> O)	0 Pa (0 mmH <sub>2</sub> O)	
Compressor	Type	Inverter scroll hermetic compressor		Inverter scroll hermetic compressor		Inverter scroll hermetic compressor		
	Starting method	Inverter	Inverter	Inverter	Inverter	Inverter	Inverter	
	Motor output	kW	10.8	12.4	12.4	12.4	12.4	13.3
	Case heater	kW	-	-	-	-	-	-
External finish		Pre-coated galvanized steel sheets (+powder coating for -BS type) <MUNSELL 3Y 7.8/1.1 or similar>		Pre-coated galvanized steel sheets (+powder coating for -BS type) <MUNSELL 3Y 7.8/1.1 or similar>		Pre-coated galvanized steel sheets (+powder coating for -BS type) <MUNSELL 3Y 7.8/1.1 or similar>		
External dimension H x W x D	mm	1,650 x 1,220 x 740	1,650 x 1,220 x 740	1,650 x 1,220 x 740	1,650 x 1,220 x 740	1,650 x 1,220 x 740	1,650 x 1,750 x 740	
	in.	65 x 48-1/16 x 29-3/16	65 x 48-1/16 x 29-3/16	65 x 48-1/16 x 29-3/16	65 x 48-1/16 x 29-3/16	65 x 48-1/16 x 29-3/16	65 x 68-15/16 x 29-3/16	
Protection devices	High pressure protection	High pressure sensor, High pressure switch at 4.15 MPa (601 psi)		High pressure sensor, High pressure switch at 4.15 MPa (601 psi)		High pressure sensor, High pressure switch at 4.15 MPa (601 psi)		
	Inverter circuit (COMP./FAN)	Over-heat protection, Over-current protection		Over-heat protection, Over-current protection		Over-heat protection, Over-current protection		
Refrigerant	Type x original charge	R410A x 11.5 kg (26 lbs)	R410A x 11.5 kg (26 lbs)	R410A x 11.5 kg (26 lbs)	R410A x 11.5 kg (26 lbs)	R410A x 11.5 kg (26 lbs)	R410A x 11.8 kg (27 lbs)	
Net weight	kg (lbs)	236 (521)	236 (521)	236 (521)	236 (521)	236 (521)	304 (671)	
Heat exchanger		Salt-resistant cross fin & copper tube		Salt-resistant cross fin & copper tube		Salt-resistant cross fin & copper tube		
Pipe between unit and distributor	Liquid pipe mm (in.)	15.88 (5/8) Brazed	15.88 (5/8) Brazed	15.88 (5/8) Brazed	15.88 (5/8) Brazed	15.88 (5/8) Brazed	15.88 (5/8) Brazed	
	Gas pipe mm (in.)	28.58 (1-1/8) Brazed	28.58 (1-1/8) Brazed	28.58 (1-1/8) Brazed	28.58 (1-1/8) Brazed	28.58 (1-1/8) Brazed	28.58 (1-1/8) Brazed	
Optional parts		Outdoor Twinning kit: CMY-Y200VBK2 Joint: CMY-Y102SS/LS-G2, CMY-Y202/302S-G2 Header: CMY-Y104/108/1010-G		Outdoor Twinning kit: CMY-Y200VBK2 Joint: CMY-Y102SS/LS-G2, CMY-Y202/302S-G2 Header: CMY-Y104/108/1010-G		Outdoor Twinning kit: CMY-Y200VBK2 Joint: CMY-Y102SS/LS-G2, CMY-Y202/302S-G2 Header: CMY-Y104/108/1010-G		

**Notes:**

\*1 Nominal cooling conditions (subject to JIS B8615-2)

	Indoor	Outdoor	Pipe length	Level difference
Cooling	27 °CD.B./19 °CW.B. (81 °FD.B./66 °FW.B.)	35 °CD.B. (95 °FD.B.)	7.5 m (24-9/16 ft.)	0 m (0 ft.)

\*2 External static pressure option is available (30Pa, 60Pa / 3.1mmH<sub>2</sub>O, 6.1mmH<sub>2</sub>O).

\*Due to continuing improvement, above specifications may be subject to change without notice.

OUTDOOR UNIT

**YKD-series - Cooling-only**

**PUCY-P YSKD (-BS)**



**Specifications**

Model	PUCY-P1000YSKD (-BS)		PUCY-P1050YSKD (-BS)		PUCY-P1100YSKD (-BS)		
Power source	3-phase 4-wire 380-400-415 V 50/60 Hz		3-phase 4-wire 380-400-415 V 50/60 Hz		3-phase 4-wire 380-400-415 V 50/60 Hz		
Cooling capacity (Nominal)	*1	kW	112.0	115.0	121.5	121.5	
		BTU/h	382,100	392,400	414,600	414,600	
		Power input kW	34.04	29.63	30.99	30.99	
		Current input A	57.4-54.5-52.6	50.0-47.5-45.8	52.3-49.7-47.9	52.3-49.7-47.9	
Temp. range of cooling	Indoor	W.B.	15.0~24.0 °C (59~75 °F)	15.0~24.0 °C (59~75 °F)	15.0~24.0 °C (59~75 °F)	15.0~24.0 °C (59~75 °F)	
	Outdoor	D.B.	10.0~52.0 °C (50~126 °F)	10.0~52.0 °C (50~126 °F)	10.0~52.0 °C (50~126 °F)	10.0~52.0 °C (50~126 °F)	
Indoor unit connectable	Total capacity	50~130% of outdoor unit capacity		50~130% of outdoor unit capacity		50~130% of outdoor unit capacity	
	Model/Quantity	P15~P600/1~50		P15~P600/1~50		P15~P600/1~50	
Sound pressure level (measured in anechoic room)	dB <A>	68		66.5		66.5	
Refrigerant piping diameter	Liquid pipe	mm (in.)	19.05 (3/4) Brazed	19.05 (3/4) Brazed	19.05 (3/4) Brazed	19.05 (3/4) Brazed	19.05 (3/4) Brazed
	Gas pipe	mm (in.)	41.28 (1-5/8) Brazed	41.28 (1-5/8) Brazed	41.28 (1-5/8) Brazed	41.28 (1-5/8) Brazed	41.28 (1-5/8) Brazed

**Set Model**

Model	PUCY-P500YKD (-BS)		PUCY-P500YKD (-BS)		PUCY-P300YKD (-BS)		PUCY-P300YKD (-BS)		PUCY-P450YKD (-BS)		PUCY-P300YKD (-BS)		PUCY-P350YKD (-BS)		PUCY-P450YKD (-BS)			
Fan	Type x Quantity	Propeller fan x 2		Propeller fan x 2		Propeller fan x 1		Propeller fan x 1		Propeller fan x 1		Propeller fan x 1		Propeller fan x 1		Propeller fan x 1		
	Air flow rate	m <sup>3</sup> /min	320		320		175		175		210		175		210		210	
		L/s	5,333		5,333		2,917		2,917		3,500		2,917		3,500		3,500	
		cfm	11,299		11,299		6,179		6,179		7,415		6,179		7,415		7,415	
Control, Driving mechanism	Inverter-control, Direct-driven by motor				Inverter-control, Direct-driven by motor				Inverter-control, Direct-driven by motor									
Motor output	0.92 x 2		0.92 x 2		0.92 x 1		0.92 x 1		0.92 x 1		0.92 x 1		0.92 x 1		0.92 x 1			
*2 External static press.	0 Pa (0 mmH <sub>2</sub> O)		0 Pa (0 mmH <sub>2</sub> O)		0 Pa (0 mmH <sub>2</sub> O)		0 Pa (0 mmH <sub>2</sub> O)		0 Pa (0 mmH <sub>2</sub> O)		0 Pa (0 mmH <sub>2</sub> O)		0 Pa (0 mmH <sub>2</sub> O)		0 Pa (0 mmH <sub>2</sub> O)			
Compressor	Type	Inverter scroll hermetic compressor				Inverter scroll hermetic compressor				Inverter scroll hermetic compressor								
	Starting method	Inverter		Inverter		Inverter		Inverter		Inverter		Inverter		Inverter		Inverter		
	Motor output	13.3		13.3		8.1		8.1		12.4		8.1		10.4		12.4		
Case heater	-		-		-		-		-		-		-		-			
External finish	Pre-coated galvanized steel sheets (+powder coating for -BS type) <MUNSELL 3Y 7.8/1.1 or similar>				Pre-coated galvanized steel sheets (+powder coating for -BS type) <MUNSELL 3Y 7.8/1.1 or similar>				Pre-coated galvanized steel sheets (+powder coating for -BS type) <MUNSELL 3Y 7.8/1.1 or similar>									
External dimension H x W x D	mm	1,650 x 1,750 x 740		1,650 x 1,750 x 740		1,650 x 920 x 740		1,650 x 920 x 740		1,650 x 1,220 x 740		1,650 x 920 x 740		1,650 x 1,220 x 740		1,650 x 1,220 x 740		
	in.	65 x 68-15/16 x 29-3/16		65 x 68-15/16 x 29-3/16		65 x 36-1/4 x 29-3/16		65 x 36-1/4 x 29-3/16		65 x 48-1/16 x 29-3/16		65 x 36-1/4 x 29-3/16		65 x 48-1/16 x 29-3/16		65 x 48-1/16 x 29-3/16		
Protection devices	High pressure protection	High pressure sensor, High pressure switch at 4.15 MPa (601 psi)				High pressure sensor, High pressure switch at 4.15 MPa (601 psi)				High pressure sensor, High pressure switch at 4.15 MPa (601 psi)								
	Inverter circuit (COMP./FAN)	Over-heat protection, Over-current protection				Over-heat protection, Over-current protection				Over-heat protection, Over-current protection								
Refrigerant	Type x original charge	R410A x 11.8 kg (27 lbs)		R410A x 11.8 kg (27 lbs)		R410A x 6.5 kg (15 lbs)		R410A x 6.5 kg (15 lbs)		R410A x 11.5 kg (26 lbs)		R410A x 6.5 kg (15 lbs)		R410A x 11.5 kg (26 lbs)		R410A x 11.5 kg (26 lbs)		
Net weight	kg (lbs)	304 (671)		304 (671)		200 (441)		200 (441)		236 (521)		200 (441)		236 (521)		236 (521)		
Heat exchanger	Salt-resistant cross fin & copper tube																	
Pipe between unit and distributor	Liquid pipe	mm (in.)	15.88 (5/8) Brazed		15.88 (5/8) Brazed		12.7 (1/2) Brazed		12.7 (1/2) Brazed		15.88 (5/8) Brazed		12.7 (1/2) Brazed		12.7 (1/2) Brazed		15.88 (5/8) Brazed	
	Gas pipe	mm (in.)	28.58 (1-1/8) Brazed		28.58 (1-1/8) Brazed		22.2 (7/8) Brazed		22.2 (7/8) Brazed		28.58 (1-1/8) Brazed		22.2 (7/8) Brazed		28.58 (1-1/8) Brazed		28.58 (1-1/8) Brazed	
Optional parts	Outdoor Twinning kit: CMY-Y200VBK2 Joint: CMY-Y102SS/LS-G2, CMY-Y202/302S-G2 Header: CMY-Y104/108/1010-G				Outdoor Twinning kit: CMY-Y300VBK3 Joint: CMY-Y102SS/LS-G2, CMY-Y202/302S-G2 Header: CMY-Y104/108/1010-G				Outdoor Twinning kit: CMY-Y300VBK3 Joint: CMY-Y102SS/LS-G2, CMY-Y202/302S-G2 Header: CMY-Y104/108/1010-G									

**Notes:**

\*1 Nominal cooling conditions (subject to JIS B8615-2)

	Indoor	Outdoor	Pipe length	Level difference
Cooling	27 °CD.B./19 °CW.B. (81 °FD.B./66 °FW.B.)	35 °CD.B. (95 °FD.B.)	7.5 m (24-9/16 ft.)	0 m (0 ft.)

\*2 External static pressure option is available (30Pa, 60Pa / 3.1mmH<sub>2</sub>O, 6.1mmH<sub>2</sub>O).

\*Due to continuing improvement, above specifications may be subject to change without notice.

Advantages of CITY MULTI

Outdoor/Heat source unit

Indoor unit

Remote Controller

Lossnay

Installation information



OUTDOOR UNIT

**YKD-series - Cooling-only**

**PUCY-P YSKD (-BS)**



**Specifications**

Model			PUCY-P1150YSKD (-BS)	PUCY-P1200YSKD (-BS)
Power source			3-phase 4-wire 380-400-415 V 50/60 Hz	
Cooling capacity (Nominal)	*1	kW	128.0	132.0
		BTU/h	436,700	450,400
	Power input	kW	33.95	37.50
	Current input	A	57.3-54.4-52.4	63.3-60.1-57.9
	EER	kW/kW	3.77	3.52
Temp. range of cooling	Indoor	W.B.	15.0~24.0 °C (59~75 °F)	
	Outdoor	D.B.	10.0~52.0 °C (50~126 °F)	
Indoor unit connectable	Total capacity		50~130% of outdoor unit capacity	
	Model/Quantity		P15~P600/1~50	
Sound pressure level (measured in anechoic room)		dB <A>	67.5	68
Refrigerant piping diameter	Liquid pipe		19.05 (3/4) Brazed	
	Gas pipe		41.28 (1-5/8) Brazed	

**Set Model**

Model			PUCY-P350YKD (-BS)	PUCY-P400YKD (-BS)	PUCY-P400YKD (-BS)	PUCY-P400YKD (-BS)	PUCY-P400YKD (-BS)	PUCY-P400YKD (-BS)		
Fan	Type x Quantity		Propeller fan x 1		Propeller fan x 1		Propeller fan x 1			
	Air flow rate	m <sup>3</sup> /min	210	210	210	210	210	210		
		L/s	3,500	3,500	3,500	3,500	3,500	3,500		
		cfm	7,415	7,415	7,415	7,415	7,415	7,415		
	Control, Driving mechanism		Inverter-control, Direct-driven by motor				Inverter-control, Direct-driven by motor			
*2	Motor output	kW	0.92 x 1	0.92 x 1	0.92 x 1	0.92 x 1	0.92 x 1	0.92 x 1		
	External static press.		0 Pa (0 mmH <sub>2</sub> O)	0 Pa (0 mmH <sub>2</sub> O)	0 Pa (0 mmH <sub>2</sub> O)	0 Pa (0 mmH <sub>2</sub> O)	0 Pa (0 mmH <sub>2</sub> O)	0 Pa (0 mmH <sub>2</sub> O)		
Compressor	Type		Inverter scroll hermetic compressor				Inverter scroll hermetic compressor			
	Starting method		Inverter		Inverter		Inverter		Inverter	
	Motor output	kW	10.4	10.8	10.8	10.8	10.8	10.8		
	Case heater	kW	-	-	-	-	-	-		
External finish		Pre-coated galvanized steel sheets (+powder coating for -BS type) <MUNSELL 3Y 7.8/1.1 or similar>				Pre-coated galvanized steel sheets (+powder coating for -BS type) <MUNSELL 3Y 7.8/1.1 or similar>				
External dimension H x W x D		mm	1,650 x 1,220 x 740	1,650 x 1,220 x 740	1,650 x 1,220 x 740	1,650 x 1,220 x 740	1,650 x 1,220 x 740	1,650 x 1,220 x 740		
Protection devices	High pressure protection		High pressure sensor, High pressure switch at 4.15 MPa (601 psi)				High pressure sensor, High pressure switch at 4.15 MPa (601 psi)			
	Inverter circuit (COMP./FAN)		Over-heat protection, Over-current protection				Over-heat protection, Over-current protection			
	Refrigerant		Type x original charge	R410A x 11.5 kg (26 lbs)	R410A x 11.5 kg (26 lbs)	R410A x 11.5 kg (26 lbs)	R410A x 11.5 kg (26 lbs)	R410A x 11.5 kg (26 lbs)	R410A x 11.5 kg (26 lbs)	
Net weight		kg (lbs)	236 (521)	236 (521)	236 (521)	236 (521)	236 (521)	236 (521)		
Heat exchanger		Salt-resistant cross fin & copper tube				Salt-resistant cross fin & copper tube				
Pipe between unit and distributor	Liquid pipe	mm (in.)	12.7 (1/2) Brazed	15.88 (5/8) Brazed	15.88 (5/8) Brazed	15.88 (5/8) Brazed	15.88 (5/8) Brazed	15.88 (5/8) Brazed		
	Gas pipe	mm (in.)	28.58 (1-1/8) Brazed	28.58 (1-1/8) Brazed	28.58 (1-1/8) Brazed	28.58 (1-1/8) Brazed	28.58 (1-1/8) Brazed	28.58 (1-1/8) Brazed		
Optional parts		Outdoor Twinning kit: CMY-Y300VBK3 Joint: CMY-Y102SS/LS-G2, CMY-Y202/302S-G2 Header: CMY-Y104/108/1010-G				Outdoor Twinning kit: CMY-Y300VBK3 Joint: CMY-Y102SS/LS-G2, CMY-Y202/302S-G2 Header: CMY-Y104/108/1010-G				

**Notes:**

\*1 Nominal cooling conditions (subject to JIS B8615-2)

	Indoor	Outdoor	Pipe length	Level difference
Cooling	27 °CD.B./19 °CW.B. (81 °FD.B./66 °FW.B.)	35 °CD.B. (95 °FD.B.)	7.5 m (24-9/16 ft.)	0 m (0 ft.)

\*2 External static pressure option is available (30Pa, 60Pa / 3.1mmH<sub>2</sub>O, 6.1mmH<sub>2</sub>O).

\*Due to continuing improvement, above specifications may be subject to change without notice.

OUTDOOR UNIT

YKD-series - Cooling-only

PUCY-P YSKD (-BS)



Advantages of CITY MULTI

Outdoor/Heat source unit

Indoor unit

Remote Controller

Lossnay

Installation information

## Specifications

Model			PUCY-P1250YSKD (-BS)		PUCY-P1300YSKD (-BS)	
Power source			3-phase 4-wire 380-400-415 V 50/60 Hz		3-phase 4-wire 380-400-415 V 50/60 Hz	
Cooling capacity (Nominal)			*1 kW	136.0	140.0	
			BTU/h	464,000	477,700	
			Power input kW	39.42	41.54	
			Current input A	66.5-63.2-60.9	70.1-66.6-64.2	
EER			kW/kW	3.45	3.37	
Temp. range of cooling			Indoor W.B.	15.0~24.0 °C (59~75 °F)	15.0~24.0 °C (59~75 °F)	
			Outdoor D.B.	10.0~52.0 °C (50~126 °F)	10.0~52.0 °C (50~126 °F)	
Indoor unit connectable			Total capacity		50~130% of outdoor unit capacity	
Model/Quantity			P15~P600/2~50		P15~P600/2~50	
Sound pressure level (measured in anechoic room)			dB <A>		68	
Refrigerant piping diameter			Liquid pipe mm (in.)		19.05 (3/4) Brazed	
			Gas pipe mm (in.)		41.28 (1-5/8) Brazed	

## Set Model

Model			PUCY-P400YKD (-BS)		PUCY-P450YKD (-BS)		PUCY-P450YKD (-BS)	
Fan			Propeller fan x 1		Propeller fan x 1		Propeller fan x 1	
Type x Quantity			210		210		210	
Air flow rate			m <sup>3</sup> /min		3,500		3,500	
			L/s		7,415		7,415	
			cfm		124		124	
Control, Driving mechanism			Inverter-control, Direct-driven by motor		Inverter-control, Direct-driven by motor		Inverter-control, Direct-driven by motor	
Motor output			kW		0.92 x 1		0.92 x 1	
External static press.			0 Pa (0 mmH <sub>2</sub> O)		0 Pa (0 mmH <sub>2</sub> O)		0 Pa (0 mmH <sub>2</sub> O)	
Compressor			Type		Inverter scroll hermetic compressor		Inverter scroll hermetic compressor	
Starting method			Inverter		Inverter		Inverter	
Motor output			kW		10.8		12.4	
Case heater			kW		-		-	
External finish			Pre-coated galvanized steel sheets (+powder coating for -BS type) <MUNSELL 3Y 7.8/1.1 or similar>		Pre-coated galvanized steel sheets (+powder coating for -BS type) <MUNSELL 3Y 7.8/1.1 or similar>		Pre-coated galvanized steel sheets (+powder coating for -BS type) <MUNSELL 3Y 7.8/1.1 or similar>	
External dimension H x W x D			mm		1,650 x 1,220 x 740		1,650 x 1,220 x 740	
			in.		65 x 48-1/16 x 29-3/16		65 x 48-1/16 x 29-3/16	
Protection devices			High pressure protection		High pressure sensor, High pressure switch at 4.15 MPa (601 psi)		High pressure sensor, High pressure switch at 4.15 MPa (601 psi)	
			Inverter circuit (COMP./FAN)		Over-heat protection, Over-current protection		Over-heat protection, Over-current protection	
Refrigerant			Type x original charge		R410A x 11.5 kg (26 lbs)		R410A x 11.5 kg (26 lbs)	
Net weight			kg (lbs)		236 (521)		236 (521)	
Heat exchanger			Salt-resistant cross fin & copper tube		Salt-resistant cross fin & copper tube		Salt-resistant cross fin & copper tube	
Pipe between unit and distributor			Liquid pipe mm (in.)		15.88 (5/8) Brazed		15.88 (5/8) Brazed	
			Gas pipe mm (in.)		28.58 (1-1/8) Brazed		28.58 (1-1/8) Brazed	
Optional parts			Outdoor Twinning kit: CMY-Y300VBK3 Joint: CMY-Y102SS/LS-G2, CMY-Y202/302S-G2 Header: CMY-Y104/108/1010-G		Outdoor Twinning kit: CMY-Y300VBK3 Joint: CMY-Y102SS/LS-G2, CMY-Y202/302S-G2 Header: CMY-Y104/108/1010-G		Outdoor Twinning kit: CMY-Y300VBK3 Joint: CMY-Y102SS/LS-G2, CMY-Y202/302S-G2 Header: CMY-Y104/108/1010-G	

## Notes:

\*1 Nominal cooling conditions (subject to JIS B8615-2)

	Indoor	Outdoor	Pipe length	Level difference
Cooling	27 °CD.B./19 °CW.B. (81 °FD.B./66 °FW.B.)	35 °CD.B. (95 °FD.B.)	7.5 m (24-9/16 ft.)	0 m (0 ft.)

\*2 External static pressure option is available (30Pa, 60Pa / 3.1mmH<sub>2</sub>O, 6.1mmH<sub>2</sub>O).

\*Due to continuing improvement, above specifications may be subject to change without notice.

OUTDOOR UNIT

**YKD-series - Cooling-only**

**PUCY-P YSKD (-BS)**



**Specifications**

Model			PUCY-P1350YSKD (-BS)	PUCY-P1400YSKD (-BS)
Power source			3-phase 4-wire 380-400-415 V 50/60 Hz	
Cooling capacity (Nominal)	*1	kW	144.0	152.0
		BTU/h	491,300	518,600
	Power input	kW	43.63	46.06
	Current input	A	73.6-69.9-67.4	77.7-73.8-71.1
	EER	kW/kW	3.30	3.30
Temp. range of cooling	Indoor	W.B.	15.0~24.0 °C (59~75 °F)	15.0~24.0 °C (59~75 °F)
	Outdoor	D.B.	10.0~52.0 °C (50~126 °F)	10.0~52.0 °C (50~126 °F)
Indoor unit connectable	Total capacity		50~130% of outdoor unit capacity	50~130% of outdoor unit capacity
	Model/Quantity		P15~P600/2~50	P15~P600/2~50
Sound pressure level (measured in anechoic room)		dB <A>	68	68.5
Refrigerant piping diameter	Liquid pipe		19.05 (3/4) Brazed	19.05 (3/4) Brazed
	Gas pipe		41.28 (1-5/8) Brazed	41.28 (1-5/8) Brazed

**Set Model**

Model			PUCY-P450YKD (-BS)	PUCY-P450YKD (-BS)	PUCY-P450YKD (-BS)	PUCY-P450YKD (-BS)	PUCY-P450YKD (-BS)	PUCY-P500YKD (-BS)
Fan	Type x Quantity		Propeller fan x 1	Propeller fan x 1	Propeller fan x 1	Propeller fan x 1	Propeller fan x 1	Propeller fan x 2
	Air flow rate	m <sup>3</sup> /min	210	210	210	210	210	320
		L/s	3,500	3,500	3,500	3,500	3,500	5,333
		cfm	7,415	7,415	7,415	7,415	7,415	11,299
	Control, Driving mechanism		Inverter-control, Direct-driven by motor			Inverter-control, Direct-driven by motor		
*2	Motor output	kW	0.92 x 1	0.92 x 1	0.92 x 1	0.92 x 1	0.92 x 2	
	External static press.		0 Pa (0 mmH <sub>2</sub> O)	0 Pa (0 mmH <sub>2</sub> O)	0 Pa (0 mmH <sub>2</sub> O)	0 Pa (0 mmH <sub>2</sub> O)	0 Pa (0 mmH <sub>2</sub> O)	0 Pa (0 mmH <sub>2</sub> O)
Compressor	Type		Inverter scroll hermetic compressor			Inverter scroll hermetic compressor		
	Starting method		Inverter	Inverter	Inverter	Inverter	Inverter	Inverter
	Motor output	kW	12.4	12.4	12.4	12.4	12.4	13.3
	Case heater		kW	-	-	-	-	-
External finish		Pre-coated galvanized steel sheets (+powder coating for -BS type) <MUNSELL 3Y 7.8/1.1 or similar>			Pre-coated galvanized steel sheets (+powder coating for -BS type) <MUNSELL 3Y 7.8/1.1 or similar>			
External dimension H x W x D		mm	1,650 x 1,220 x 740	1,650 x 1,220 x 740	1,650 x 1,220 x 740	1,650 x 1,220 x 740	1,650 x 1,220 x 740	1,650 x 1,750 x 740
		in.	65 x 48-1/16 x 29-3/16	65 x 48-1/16 x 29-3/16	65 x 48-1/16 x 29-3/16	65 x 48-1/16 x 29-3/16	65 x 48-1/16 x 29-3/16	65 x 68-15/16 x 29-3/16
Protection devices	High pressure protection		High pressure sensor, High pressure switch at 4.15 MPa (601 psi)			High pressure sensor, High pressure switch at 4.15 MPa (601 psi)		
	Inverter circuit (COMP./FAN)		Over-heat protection, Over-current protection			Over-heat protection, Over-current protection		
Refrigerant	Type x original charge		R410A x 11.5 kg (26 lbs)	R410A x 11.5 kg (26 lbs)	R410A x 11.5 kg (26 lbs)	R410A x 11.5 kg (26 lbs)	R410A x 11.5 kg (26 lbs)	R410A x 11.8 kg (27 lbs)
Net weight		kg (lbs)	236 (521)	236 (521)	236 (521)	236 (521)	236 (521)	304 (671)
Heat exchanger		Salt-resistant cross fin & copper tube			Salt-resistant cross fin & copper tube			
Pipe between unit and distributor	Liquid pipe	mm (in.)	15.88 (5/8) Brazed	15.88 (5/8) Brazed	15.88 (5/8) Brazed	15.88 (5/8) Brazed	15.88 (5/8) Brazed	15.88 (5/8) Brazed
	Gas pipe	mm (in.)	28.58 (1-1/8) Brazed	28.58 (1-1/8) Brazed	28.58 (1-1/8) Brazed	28.58 (1-1/8) Brazed	28.58 (1-1/8) Brazed	28.58 (1-1/8) Brazed
Optional parts		Outdoor Twinning kit: CMY-Y300VBK3 Joint: CMY-Y102SS/LS-G2, CMY-Y202/302S-G2 Header: CMY-Y104/108/1010-G			Outdoor Twinning kit: CMY-Y300VBK3 Joint: CMY-Y102SS/LS-G2, CMY-Y202/302S-G2 Header: CMY-Y104/108/1010-G			

**Notes:**

\*1 Nominal cooling conditions (subject to JIS B8615-2)

	Indoor	Outdoor	Pipe length	Level difference
Cooling	27 °CD.B./19 °CW.B. (81 °FD.B./66 °FW.B.)	35 °CD.B. (95 °FD.B.)	7.5 m (24-9/16 ft.)	0 m (0 ft.)

\*2 External static pressure option is available (30Pa, 60Pa / 3.1mmH<sub>2</sub>O, 6.1mmH<sub>2</sub>O).

\*Due to continuing improvement, above specifications may be subject to change without notice.

OUTDOOR UNIT

YKD-series - Cooling-only

PUCY-P YSKD (-BS)



## Specifications

Model			PUCY-P1450YSKD (-BS)	PUCY-P1500YSKD (-BS)
Power source			3-phase 4-wire 380-400-415 V 50/60 Hz	
Cooling capacity (Nominal)			160.0	168.0
			545,900	573,200
Power input			48.63	51.06
Current input			82.0-77.9-75.1	86.1-81.8-78.9
EER			3.29	3.29
Temp. range of cooling			15.0~24.0 °C (59~75 °F)	15.0~24.0 °C (59~75 °F)
Indoor			W.B.	D.B.
Outdoor			10.0~52.0 °C (50~126 °F)	10.0~52.0 °C (50~126 °F)
Indoor unit connectable			50~130% of outdoor unit capacity	50~130% of outdoor unit capacity
Total capacity			P15~P600/2~50	P15~P600/2~50
Model/Quantity				
Sound pressure level (measured in anechoic room)			69.5	70
Refrigerant piping diameter			19.05 (3/4) Brazed	19.05 (3/4) Brazed
Liquid pipe			mm (in.)	mm (in.)
Gas pipe			41.28 (1-5/8) Brazed	41.28 (1-5/8) Brazed

## Set Model

Model			PUCY-P450YKD (-BS)	PUCY-P500YKD (-BS)	PUCY-P500YKD (-BS)	PUCY-P500YKD (-BS)	PUCY-P500YKD (-BS)	PUCY-P500YKD (-BS)
Fan			Propeller fan x 1	Propeller fan x 2	Propeller fan x 2	Propeller fan x 2	Propeller fan x 2	Propeller fan x 2
Type x Quantity			210	320	320	320	320	320
Air flow rate			m <sup>3</sup> /min	3,500	5,333	5,333	5,333	5,333
			L/s	7,415	11,299	11,299	11,299	11,299
			cfm					
Control, Driving mechanism			Inverter-control, Direct-driven by motor			Inverter-control, Direct-driven by motor		
Motor output			0.92 x 1	0.92 x 2	0.92 x 2	0.92 x 2	0.92 x 2	0.92 x 2
External static press.			0 Pa (0 mmH <sub>2</sub> O)	0 Pa (0 mmH <sub>2</sub> O)	0 Pa (0 mmH <sub>2</sub> O)	0 Pa (0 mmH <sub>2</sub> O)	0 Pa (0 mmH <sub>2</sub> O)	0 Pa (0 mmH <sub>2</sub> O)
Compressor			Inverter scroll hermetic compressor			Inverter scroll hermetic compressor		
Type			Inverter	Inverter	Inverter	Inverter	Inverter	Inverter
Starting method			12.4	13.3	13.3	13.3	13.3	13.3
Motor output			kW	-	-	-	-	-
Case heater			kW					
External finish			Pre-coated galvanized steel sheets (+powder coating for -BS type) <MUNSELL 3Y 7.8/1.1 or similar>			Pre-coated galvanized steel sheets (+powder coating for -BS type) <MUNSELL 3Y 7.8/1.1 or similar>		
External dimension H x W x D			mm	1,650 x 1,220 x 740	1,650 x 1,750 x 740	1,650 x 1,750 x 740	1,650 x 1,750 x 740	1,650 x 1,750 x 740
			in.	65 x 48-1/16 x 29-3/16	65 x 68-15/16 x 29-3/16	65 x 68-15/16 x 29-3/16	65 x 68-15/16 x 29-3/16	65 x 68-15/16 x 29-3/16
Protection devices			High pressure protection			High pressure protection		
			High pressure sensor, High pressure switch at 4.15 MPa (601 psi)			High pressure sensor, High pressure switch at 4.15 MPa (601 psi)		
			Inverter circuit (COMP./FAN)			Over-heat protection, Over-current protection		
Refrigerant			Type x original charge	R410A x 11.5 kg (26 lbs)	R410A x 11.8 kg (27 lbs)	R410A x 11.8 kg (27 lbs)	R410A x 11.8 kg (27 lbs)	R410A x 11.8 kg (27 lbs)
Net weight			kg (lbs)	236 (521)	304 (671)	304 (671)	304 (671)	304 (671)
Heat exchanger			Salt-resistant cross fin & copper tube			Salt-resistant cross fin & copper tube		
Pipe between unit and distributor			Liquid pipe	mm (in.)	15.88 (5/8) Brazed	15.88 (5/8) Brazed	15.88 (5/8) Brazed	15.88 (5/8) Brazed
			Gas pipe	mm (in.)	28.58 (1-1/8) Brazed	28.58 (1-1/8) Brazed	28.58 (1-1/8) Brazed	28.58 (1-1/8) Brazed
Optional parts			Outdoor Twinning kit: CMY-Y300VBK3 Joint: CMY-Y102SS/LS-G2, CMY-Y202/302S-G2 Header: CMY-Y104/108/1010-G			Outdoor Twinning kit: CMY-Y300VBK3 Joint: CMY-Y102SS/LS-G2, CMY-Y202/302S-G2 Header: CMY-Y104/108/1010-G		

## Notes:

\*1 Nominal cooling conditions (subject to JIS B8615-2)

	Indoor	Outdoor	Pipe length	Level difference
Cooling	27 °CD.B./19 °CW.B. (81 °FD.B./66 °FW.B.)	35 °CD.B. (95 °FD.B.)	7.5 m (24-9/16 ft.)	0 m (0 ft.)

\*2 External static pressure option is available (30Pa, 60Pa / 3.1mmH<sub>2</sub>O, 6.1mmH<sub>2</sub>O).

\*Due to continuing improvement, above specifications may be subject to change without notice.



OUTDOOR UNIT

**YKD-series - Cooling-only High Efficiency**

**PUCY-EP YSKD (-BS)**



**Specifications**

Model		PUCY-EP400YSKD (-BS)	PUCY-EP450YSKD (-BS)	PUCY-EP500YSKD (-BS)
Power source		3-phase 4-wire 380-400-415 V 50/60 Hz	3-phase 4-wire 380-400-415 V 50/60 Hz	3-phase 4-wire 380-400-415 V 50/60 Hz
Cooling capacity (Nominal)	*1 kW	44.8	50.4	56.0
	BTU/h	152,900	172,000	191,100
	Power input kW	9.93	11.37	12.84
	Current input A	16.7-15.9-15.3	19.1-18.2-17.5	21.6-20.5-19.8
	EER kW/kW	4.51	4.43	4.36
Temp. range of cooling	Indoor W.B.	15.0~24.0 °C (59~75 °F)	15.0~24.0 °C (59~75 °F)	15.0~24.0 °C (59~75 °F)
	Outdoor D.B.	10.0~52.0 °C (50~126 °F)	10.0~52.0 °C (50~126 °F)	10.0~52.0 °C (50~126 °F)
Indoor unit connectable	Total capacity	50~130% of outdoor unit capacity	50~130% of outdoor unit capacity	50~130% of outdoor unit capacity
	Model/Quantity	P15~P400/1~34	P15~P400/1~39	P15~P500/1~43
Sound pressure level (measured in anechoic room)	dB <A>	60	60.5	61
Refrigerant piping diameter	Liquid pipe mm (in.)	12.7 (1/2) Brazed	15.88 (5/8) Brazed	15.88 (5/8) Brazed
	Gas pipe mm (in.)	28.58 (1-1/8) Brazed	28.58 (1-1/8) Brazed	28.58 (1-1/8) Brazed

**Set Model**

Model		PUCY-P200YKD (-BS)	PUCY-P200YKD (-BS)	PUCY-P200YKD (-BS)	PUCY-P250YKD (-BS)	PUCY-P250YKD (-BS)	PUCY-P250YKD (-BS)	
Fan	Type x Quantity	Propeller fan x 1	Propeller fan x 1	Propeller fan x 1	Propeller fan x 1	Propeller fan x 1	Propeller fan x 1	
	Air flow rate	m <sup>3</sup> /min	175	175	175	175	175	175
		L/s	2,917	2,917	2,917	2,917	2,917	2,917
		cfm	6,179	6,179	6,179	6,179	6,179	6,179
	Control, Driving mechanism	Inverter-control, Direct-driven by motor		Inverter-control, Direct-driven by motor		Inverter-control, Direct-driven by motor		
*2 Motor output	kW	0.92 x 1	0.92 x 1	0.92 x 1	0.92 x 1	0.92 x 1	0.92 x 1	
Compressor	External static press.	0 Pa (0 mmH <sub>2</sub> O)	0 Pa (0 mmH <sub>2</sub> O)	0 Pa (0 mmH <sub>2</sub> O)	0 Pa (0 mmH <sub>2</sub> O)	0 Pa (0 mmH <sub>2</sub> O)	0 Pa (0 mmH <sub>2</sub> O)	
	Type	Inverter scroll hermetic compressor		Inverter scroll hermetic compressor		Inverter scroll hermetic compressor		
	Starting method	Inverter	Inverter	Inverter	Inverter	Inverter	Inverter	
	Motor output	kW	5.5	5.5	5.5	6.9	6.9	6.9
	Case heater	kW	-	-	-	-	-	-
External finish	Pre-coated galvanized steel sheets (+powder coating for -BS type) <MUNSELL 3Y 7.8/1.1 or similar>		Pre-coated galvanized steel sheets (+powder coating for -BS type) <MUNSELL 3Y 7.8/1.1 or similar>		Pre-coated galvanized steel sheets (+powder coating for -BS type) <MUNSELL 3Y 7.8/1.1 or similar>			
	External dimension H x W x D	mm	1,650 x 920 x 740	1,650 x 920 x 740	1,650 x 920 x 740	1,650 x 920 x 740	1,650 x 920 x 740	
Protection devices	High pressure protection	High pressure sensor, High pressure switch at 4.15 MPa (601 psi)		High pressure sensor, High pressure switch at 4.15 MPa (601 psi)		High pressure sensor, High pressure switch at 4.15 MPa (601 psi)		
	Inverter circuit (COMP./FAN)	Over-heat protection, Over-current protection		Over-heat protection, Over-current protection		Over-heat protection, Over-current protection		
	Refrigerant	Type x original charge	R410A x 5.5 kg (13 lbs)	R410A x 5.5 kg (13 lbs)	R410A x 5.5 kg (13 lbs)	R410A x 6.5 kg (15 lbs)	R410A x 6.5 kg (15 lbs)	
Net weight	kg (lbs)	174 (384)	174 (384)	174 (384)	183 (404)	183 (404)		
Heat exchanger	Salt-resistant cross fin & copper tube		Salt-resistant cross fin & copper tube		Salt-resistant cross fin & copper tube			
Pipe between unit and distributor	Liquid pipe	mm (in.)	9.52 (3/8) Brazed	9.52 (3/8) Brazed	9.52 (3/8) Brazed	9.52 (3/8) Brazed	9.52 (3/8) Brazed	
	Gas pipe	mm (in.)	22.2 (7/8) Brazed	22.2 (7/8) Brazed	22.2 (7/8) Brazed	22.2 (7/8) Brazed	22.2 (7/8) Brazed	
Optional parts	Outdoor Twinning kit: CMY-Y100VBK3 Joint: CMY-Y102SS/LS-G2, CMY-Y202S-G2 Header: CMY-Y104/108/1010-G		Outdoor Twinning kit: CMY-Y100VBK3 Joint: CMY-Y102SS/LS-G2, CMY-Y202S-G2 Header: CMY-Y104/108/1010-G		Outdoor Twinning kit: CMY-Y100VBK3 Joint: CMY-Y102SS/LS-G2, CMY-Y202S-G2 Header: CMY-Y104/108/1010-G			

**Notes:**

\*1 Nominal cooling conditions (subject to JIS B8615-2)

	Indoor	Outdoor	Pipe length	Level difference
Cooling	27 °CD.B./19 °CW.B. (81 °FD.B./66 °FW.B.)	35 °CD.B. (95 °FD.B.)	7.5 m (24-9/16 ft.)	0 m (0 ft.)

\*2 External static pressure option is available (30Pa, 60Pa / 3.1mmH<sub>2</sub>O, 6.1mmH<sub>2</sub>O).

\*Due to continuing improvement, above specifications may be subject to change without notice.

OUTDOOR UNIT

## YKD-series - Cooling-only High Efficiency

## PUCY-EP YSKD (-BS)



## Specifications

Model		PUCY-EP650YSKD (-BS)		PUCY-EP700YSKD (-BS)	
Power source		3-phase 4-wire 380-400-415 V 50/60 Hz		3-phase 4-wire 380-400-415 V 50/60 Hz	
Cooling capacity (Nominal)		*1 kW	73.5	80.0	
		BTU/h	250,800	273,000	
Power input		kW	18.32	19.75	
Current input		A	30.9-29.3-28.3	33.3-31.6-30.5	
EER		kW/kW	4.01	4.05	
Temp. range of cooling		Indoor W.B.	15.0~24.0 °C (59~75 °F)	15.0~24.0 °C (59~75 °F)	
		Outdoor D.B.	10.0~52.0 °C (50~126 °F)	10.0~52.0 °C (50~126 °F)	
Indoor unit connectable		Total capacity	50~130% of outdoor unit capacity	50~130% of outdoor unit capacity	
		Model/Quantity	P15~P600/1~50	P15~P600/1~50	
Sound pressure level (measured in anechoic room)		dB <A>	64	64	
Refrigerant piping diameter		Liquid pipe mm (in.)	15.88 (5/8) Brazed	19.05 (3/4) Brazed	
		Gas pipe mm (in.)	28.58 (1-1/8) Brazed	34.93 (1-3/8) Brazed	

## Set Model

Model		PUCY-P300YKD (-BS)		PUCY-P350YKD (-BS)		PUCY-P350YKD (-BS)		PUCY-P350YKD (-BS)	
Fan		Type x Quantity		Propeller fan x 1		Propeller fan x 1		Propeller fan x 1	
		Air flow rate		m <sup>3</sup> /min		210		210	
				L/s		3,500		3,500	
				cfm		6,179		7,415	
Control, Driving mechanism		Inverter-control, Direct-driven by motor				Inverter-control, Direct-driven by motor			
Compressor		Motor output		0.92 x 1		0.92 x 1		0.92 x 1	
		External static press.		0 Pa (0 mmH <sub>2</sub> O)		0 Pa (0 mmH <sub>2</sub> O)		0 Pa (0 mmH <sub>2</sub> O)	
Compressor		Type		Inverter scroll hermetic compressor					
		Starting method		Inverter		Inverter		Inverter	
		Motor output		8.1		10.4		10.4	
		Case heater		-		-		-	
External finish		Pre-coated galvanized steel sheets (+powder coating for -BS type) <MUNSELL 3Y 7.8/1.1 or similar>				Pre-coated galvanized steel sheets (+powder coating for -BS type) <MUNSELL 3Y 7.8/1.1 or similar>			
External dimension H x W x D		mm		1,650 x 920 x 740		1,650 x 1,220 x 740		1,650 x 1,220 x 740	
		in.		65 x 36-1/4 x 29-3/16		65 x 48-1/16 x 29-3/16		65 x 48-1/16 x 29-3/16	
Protection devices		High pressure protection		High pressure sensor, High pressure switch at 4.15 MPa (601 psi)					
		Inverter circuit (COMP./FAN)		Over-heat protection, Over-current protection					
Refrigerant		Type x original charge		R410A x 6.5 kg (15 lbs)		R410A x 11.5 kg (26 lbs)		R410A x 11.5 kg (26 lbs)	
Net weight		kg (lbs)		200 (441)		236 (521)		236 (521)	
Heat exchanger		Salt-resistant cross fin & copper tube							
Pipe between unit and distributor		Liquid pipe		12.7 (1/2) Brazed		12.7 (1/2) Brazed		12.7 (1/2) Brazed	
		Gas pipe		22.2 (7/8) Brazed		28.58 (1-1/8) Brazed		28.58 (1-1/8) Brazed	
Optional parts		Outdoor Twinning kit: CMY-Y100VBK3 Joint: CMY-Y102SS/LS-G2, CMY-Y202/302S-G2 Header: CMY-Y104/108/1010-G				Outdoor Twinning kit: CMY-Y200VBK2 Joint: CMY-Y102SS/LS-G2, CMY-Y202/302S-G2 Header: CMY-Y104/108/1010-G			

## Notes:

\*1 Nominal cooling conditions (subject to JIS B8615-2)

	Indoor	Outdoor	Pipe length	Level difference
Cooling	27 °CD.B./19 °CW.B. (81 °FD.B./66 °FW.B.)	35 °CD.B. (95 °FD.B.)	7.5 m (24-9/16 ft.)	0 m (0 ft.)

\*2 External static pressure option is available (30Pa, 60Pa / 3.1mmH<sub>2</sub>O, 6.1mmH<sub>2</sub>O).

\*Due to continuing improvement, above specifications may be subject to change without notice.

Advantages of CITY MULTI

Outdoor/Heat source unit

Indoor unit

Remote Controller

Lossnay

Installation information

OUTDOOR UNIT

**YKD-series - Cooling-only High Efficiency**

**PUCY-EP YSKD (-BS)**



**Specifications**

Model			PUCY-EP750YSKD (-BS)	PUCY-EP800YSKD (-BS)
Power source			3-phase 4-wire 380-400-415 V 50/60 Hz	
Cooling capacity (Nominal)	*1	kW	84.8	90.4
		BTU/h	289,300	308,400
		Power input kW	19.44	20.97
		Current input A	32.8-31.1-30.0	35.4-33.6-32.4
		EER kW/kW	4.36	4.31
Temp. range of cooling	Indoor	W.B.	15.0~24.0 °C (59~75 °F)	
	Outdoor	D.B.	10.0~52.0 °C (50~126 °F)	
Indoor unit connectable	Total capacity	50~130% of outdoor unit capacity		50~130% of outdoor unit capacity
	Model/Quantity	P15~P600/1~50		P15~P600/1~50
Sound pressure level (measured in anechoic room)	dB <A>	64		64
Refrigerant piping diameter	Liquid pipe	mm (in.)	19.05 (3/4) Brazed	
	Gas pipe	mm (in.)	34.93 (1-3/8) Brazed	

**Set Model**

Model			PUCY-P200YKD (-BS)	PUCY-P200YKD (-BS)	PUCY-P350YKD (-BS)	PUCY-P200YKD (-BS)	PUCY-P250YKD (-BS)	PUCY-P350YKD (-BS)
Fan	Type x Quantity	Propeller fan x 1		Propeller fan x 1	Propeller fan x 1	Propeller fan x 1	Propeller fan x 1	Propeller fan x 1
	Air flow rate	m <sup>3</sup> /min	175	175	210	175	175	210
		L/s	2,917	2,917	3,500	2,917	2,917	3,500
		cfm	6,179	6,179	7,415	6,179	6,179	7,415
Control, Driving mechanism	*2	Inverter-control, Direct-driven by motor			Inverter-control, Direct-driven by motor			
	Motor output	kW	0.92 x 1	0.92 x 1	0.92 x 1	0.92 x 1	0.92 x 1	0.92 x 1
	External static press.	0 Pa (0 mmH <sub>2</sub> O)	0 Pa (0 mmH <sub>2</sub> O)	0 Pa (0 mmH <sub>2</sub> O)	0 Pa (0 mmH <sub>2</sub> O)	0 Pa (0 mmH <sub>2</sub> O)	0 Pa (0 mmH <sub>2</sub> O)	
Compressor	Type	Inverter scroll hermetic compressor			Inverter scroll hermetic compressor			
	Starting method	Inverter	Inverter	Inverter	Inverter	Inverter	Inverter	
	Motor output	kW	5.5	5.5	10.4	5.5	6.9	10.4
	Case heater	kW	-	-	-	-	-	-
External finish	Pre-coated galvanized steel sheets (+powder coating for -BS type) <MUNSELL 3Y 7.8/1.1 or similar>			Pre-coated galvanized steel sheets (+powder coating for -BS type) <MUNSELL 3Y 7.8/1.1 or similar>				
External dimension H x W x D	mm	1,650 x 920 x 740	1,650 x 920 x 740	1,650 x 1,220 x 740	1,650 x 920 x 740	1,650 x 920 x 740	1,650 x 1,220 x 740	
	in.	65 x 36-1/4 x 29-3/16	65 x 36-1/4 x 29-3/16	65 x 48-1/16 x 29-3/16	65 x 36-1/4 x 29-3/16	65 x 36-1/4 x 29-3/16	65 x 48-1/16 x 29-3/16	
Protection devices	High pressure protection	High pressure sensor, High pressure switch at 4.15 MPa (601 psi)			High pressure sensor, High pressure switch at 4.15 MPa (601 psi)			
	Inverter circuit (COMP./FAN)	Over-heat protection, Over-current protection			Over-heat protection, Over-current protection			
Refrigerant	Type x original charge	R410A x 5.5 kg (13 lbs)	R410A x 5.5 kg (13 lbs)	R410A x 11.5 kg (26 lbs)	R410A x 5.5 kg (13 lbs)	R410A x 6.5 kg (15 lbs)	R410A x 11.5 kg (26 lbs)	
Net weight	kg (lbs)	174 (384)	174 (384)	236 (521)	174 (384)	183 (404)	236 (521)	
Heat exchanger	Salt-resistant cross fin & copper tube			Salt-resistant cross fin & copper tube				
Pipe between unit and distributor	Liquid pipe	mm (in.)	9.52 (3/8) Brazed	9.52 (3/8) Brazed	12.7 (1/2) Brazed	9.52 (3/8) Brazed	9.52 (3/8) Brazed	12.7 (1/2) Brazed
	Gas pipe	mm (in.)	22.2 (7/8) Brazed	22.2 (7/8) Brazed	28.58 (1-1/8) Brazed	22.2 (7/8) Brazed	22.2 (7/8) Brazed	28.58 (1-1/8) Brazed
Optional parts	Outdoor Twinning kit: CMY-Y300VBK3 Joint: CMY-Y102SS/LS-G2, CMY-Y202/302S-G2 Header: CMY-Y104/108/1010-G			Outdoor Twinning kit: CMY-Y300VBK3 Joint: CMY-Y102SS/LS-G2, CMY-Y202/302S-G2 Header: CMY-Y104/108/1010-G				

**Notes:**

\*1 Nominal cooling conditions (subject to JIS B8615-2)

	Indoor	Outdoor	Pipe length	Level difference
Cooling	27 °CD.B./19 °CW.B. (81 °FD.B./66 °FW.B.)	35 °CD.B. (95 °FD.B.)	7.5 m (24-9/16 ft.)	0 m (0 ft.)

\*2 External static pressure option is available (30Pa, 60Pa / 3.1mmH<sub>2</sub>O, 6.1mmH<sub>2</sub>O).

\*Due to continuing improvement, above specifications may be subject to change without notice.

OUTDOOR UNIT

## YKD-series - Cooling-only High Efficiency

## PUCY-EP YSKD (-BS)



Advantages of CITY MULTI

Outdoor/Heat source unit

Indoor unit

Remote Controller

Lossnay

Installation information

## Specifications

Model			PUCY-EP850YSKD (-BS)	PUCY-EP900YSKD (-BS)
Power source			3-phase 4-wire 380-400-415 V 50/60 Hz	
Cooling capacity (Nominal)			96.0	101.5
			327,600	346,300
Power input			22.53	24.57
Current input			38.0-36.1-34.8	41.4-39.4-37.9
EER			4.26	4.13
Temp. range of cooling	Indoor	W.B.	15.0~24.0 °C (59~75 °F)	15.0~24.0 °C (59~75 °F)
	Outdoor	D.B.	10.0~52.0 °C (50~126 °F)	10.0~52.0 °C (50~126 °F)
Indoor unit connectable	Total capacity		50~130% of outdoor unit capacity	50~130% of outdoor unit capacity
	Model/Quantity		P15~P600/1~50	P15~P600/1~50
Sound pressure level (measured in anechoic room)			64	65
Refrigerant piping diameter			19.05 (3/4) Brazed	19.05 (3/4) Brazed
			41.28 (1-5/8) Brazed	41.28 (1-5/8) Brazed

## Set Model

Model			PUCY-P250YKD (-BS)	PUCY-P250YKD (-BS)	PUCY-P350YKD (-BS)	PUCY-P250YKD (-BS)	PUCY-P300YKD (-BS)	PUCY-P350YKD (-BS)
Fan	Type x Quantity		Propeller fan x 1	Propeller fan x 1	Propeller fan x 1	Propeller fan x 1	Propeller fan x 1	Propeller fan x 1
	Air flow rate	m <sup>3</sup> /min	175	175	210	175	175	210
		L/s	2,917	2,917	3,500	2,917	2,917	3,500
		cfm	6,179	6,179	7,415	6,179	6,179	7,415
	Control, Driving mechanism		Inverter-control, Direct-driven by motor			Inverter-control, Direct-driven by motor		
Compressor	Motor output		0.92 x 1	0.92 x 1	0.92 x 1	0.92 x 1	0.92 x 1	0.92 x 1
	External static press.		0 Pa (0 mmH <sub>2</sub> O)	0 Pa (0 mmH <sub>2</sub> O)	0 Pa (0 mmH <sub>2</sub> O)	0 Pa (0 mmH <sub>2</sub> O)	0 Pa (0 mmH <sub>2</sub> O)	0 Pa (0 mmH <sub>2</sub> O)
	Type		Inverter scroll hermetic compressor			Inverter scroll hermetic compressor		
External finish	Starting method		Inverter	Inverter	Inverter	Inverter	Inverter	Inverter
	Motor output		6.9	6.9	10.4	6.9	8.1	10.4
	Case heater		-	-	-	-	-	-
External dimension H x W x D			Pre-coated galvanized steel sheets (+powder coating for -BS type) <MUNSELL 3Y 7.8/1.1 or similar>			Pre-coated galvanized steel sheets (+powder coating for -BS type) <MUNSELL 3Y 7.8/1.1 or similar>		
Protection devices	High pressure protection		High pressure sensor, High pressure switch at 4.15 MPa (601 psi)			High pressure sensor, High pressure switch at 4.15 MPa (601 psi)		
	Inverter circuit (COMP./FAN)		Over-heat protection, Over-current protection			Over-heat protection, Over-current protection		
Refrigerant	Type x original charge		R410A x 6.5 kg (15 lbs)	R410A x 6.5 kg (15 lbs)	R410A x 11.5 kg (26 lbs)	R410A x 6.5 kg (15 lbs)	R410A x 6.5 kg (15 lbs)	R410A x 11.5 kg (26 lbs)
Net weight	kg (lbs)		183 (404)	183 (404)	236 (521)	183 (404)	200 (441)	236 (521)
Heat exchanger			Salt-resistant cross fin & copper tube			Salt-resistant cross fin & copper tube		
Pipe between unit and distributor	Liquid pipe	mm (in.)	9.52 (3/8) Brazed	9.52 (3/8) Brazed	12.7 (1/2) Brazed	9.52 (3/8) Brazed	12.7 (1/2) Brazed	12.7 (1/2) Brazed
	Gas pipe	mm (in.)	22.2 (7/8) Brazed	22.2 (7/8) Brazed	28.58 (1-1/8) Brazed	22.2 (7/8) Brazed	22.2 (7/8) Brazed	28.58 (1-1/8) Brazed
Optional parts			Outdoor Twinning kit: CMY-Y300VBK3 Joint: CMY-Y102SS/LS-G2, CMY-Y202/302S-G2 Header: CMY-Y104/108/1010-G			Outdoor Twinning kit: CMY-Y300VBK3 Joint: CMY-Y102SS/LS-G2, CMY-Y202/302S-G2 Header: CMY-Y104/108/1010-G		

## Notes:

\*1 Nominal cooling conditions (subject to JIS B8615-2)

	Indoor	Outdoor	Pipe length	Level difference
Cooling	27 °CD.B./19 °CW.B. (81 °FD.B./66 °FW.B.)	35 °CD.B. (95 °FD.B.)	7.5 m (24-9/16 ft.)	0 m (0 ft.)

\*2 External static pressure option is available (30Pa, 60Pa / 3.1mmH<sub>2</sub>O, 6.1mmH<sub>2</sub>O).

\*Due to continuing improvement, above specifications may be subject to change without notice.



OUTDOOR UNIT

# YKD-series - Cooling-only High Efficiency

## PUCY-EP YSKD (-BS)



### Specifications

Model			PUCY-EP950YSKD (-BS)	PUCY-EP1000YSKD (-BS)
Power source			3-phase 4-wire 380-400-415 V 50/60 Hz	
Cooling capacity (Nominal)	*1	kW	107.0	113.5
		BTU/h	365,100	387,300
	Power input	kW	26.81	28.80
	Current input	A	45.2-42.9-41.4	48.6-46.1-44.5
	EER	kW/kW	3.99	3.94
Temp. range of cooling	Indoor	W.B.	15.0~24.0 °C (59~75 °F)	15.0~24.0 °C (59~75 °F)
	Outdoor	D.B.	10.0~52.0 °C (50~126 °F)	10.0~52.0 °C (50~126 °F)
Indoor unit connectable	Total capacity		50~130% of outdoor unit capacity	50~130% of outdoor unit capacity
	Model/Quantity		P15~P600/1~50	P15~P600/1~50
Sound pressure level (measured in anechoic room)		dB <A>	66	66
Refrigerant piping diameter	Liquid pipe		19.05 (3/4) Brazed	19.05 (3/4) Brazed
	Gas pipe		41.28 (1-5/8) Brazed	41.28 (1-5/8) Brazed

### Set Model

Model			PUCY-P300YKD (-BS)	PUCY-P300YKD (-BS)	PUCY-P350YKD (-BS)	PUCY-P300YKD (-BS)	PUCY-P350YKD (-BS)	PUCY-P350YKD (-BS)
Fan	Type x Quantity		Propeller fan x 1	Propeller fan x 1	Propeller fan x 1	Propeller fan x 1	Propeller fan x 1	Propeller fan x 1
	Air flow rate	m <sup>3</sup> /min	175	175	210	175	210	210
		L/s	2,917	2,917	3,500	2,917	3,500	3,500
		cfm	6,179	6,179	7,415	6,179	7,415	7,415
Control, Driving mechanism			Inverter-control, Direct-driven by motor			Inverter-control, Direct-driven by motor		
*2	Motor output	kW	0.92 x 1	0.92 x 1	0.92 x 1	0.92 x 1	0.92 x 1	0.92 x 1
	External static press.		0 Pa (0 mmH <sub>2</sub> O)	0 Pa (0 mmH <sub>2</sub> O)	0 Pa (0 mmH <sub>2</sub> O)	0 Pa (0 mmH <sub>2</sub> O)	0 Pa (0 mmH <sub>2</sub> O)	0 Pa (0 mmH <sub>2</sub> O)
	Compressor		Inverter scroll hermetic compressor			Inverter scroll hermetic compressor		
External finish	Type		Pre-coated galvanized steel sheets (+powder coating for -BS type) <MUNSELL 3Y 7.8/1.1 or similar>			Pre-coated galvanized steel sheets (+powder coating for -BS type) <MUNSELL 3Y 7.8/1.1 or similar>		
	Starting method		Inverter	Inverter	Inverter	Inverter	Inverter	Inverter
	Motor output	kW	8.1	8.1	10.4	8.1	10.4	10.4
Case heater		kW	-	-	-	-	-	-
External dimension H x W x D			mm			mm		
			1,650 x 920 x 740	1,650 x 920 x 740	1,650 x 1,220 x 740	1,650 x 920 x 740	1,650 x 1,220 x 740	1,650 x 1,220 x 740
			in.	65 x 36-1/4 x 29-3/16	65 x 36-1/4 x 29-3/16	65 x 48-1/16 x 29-3/16	65 x 36-1/4 x 29-3/16	65 x 48-1/16 x 29-3/16
Protection devices	High pressure protection		High pressure sensor, High pressure switch at 4.15 MPa (601 psi)			High pressure sensor, High pressure switch at 4.15 MPa (601 psi)		
	Inverter circuit (COMP./FAN)		Over-heat protection, Over-current protection			Over-heat protection, Over-current protection		
Refrigerant	Type x original charge		R410A x 6.5 kg (15 lbs)	R410A x 6.5 kg (15 lbs)	R410A x 11.5 kg (26 lbs)	R410A x 6.5 kg (15 lbs)	R410A x 11.5 kg (26 lbs)	R410A x 11.5 kg (26 lbs)
Net weight		kg (lbs)	200 (441)	200 (441)	236 (521)	200 (441)	236 (521)	236 (521)
Heat exchanger			Salt-resistant cross fin & copper tube			Salt-resistant cross fin & copper tube		
Pipe between unit and distributor	Liquid pipe	mm (in.)	12.7 (1/2) Brazed	12.7 (1/2) Brazed	12.7 (1/2) Brazed	12.7 (1/2) Brazed	12.7 (1/2) Brazed	12.7 (1/2) Brazed
	Gas pipe	mm (in.)	22.2 (7/8) Brazed	22.2 (7/8) Brazed	28.58 (1-1/8) Brazed	22.2 (7/8) Brazed	28.58 (1-1/8) Brazed	28.58 (1-1/8) Brazed
Optional parts			Outdoor Twinning kit: CMY-Y300VBK3 Joint: CMY-Y102SS/LS-G2, CMY-Y202/302S-G2 Header: CMY-Y104/108/1010-G			Outdoor Twinning kit: CMY-Y300VBK3 Joint: CMY-Y102SS/LS-G2, CMY-Y202/302S-G2 Header: CMY-Y104/108/1010-G		

### Notes:

\*1 Nominal cooling conditions (subject to JIS B8615-2)

	Indoor	Outdoor	Pipe length	Level difference
Cooling	27 °CD.B./19 °CW.B. (81 °FD.B./66 °FW.B.)	35 °CD.B. (95 °FD.B.)	7.5 m (24-9/16 ft.)	0 m (0 ft.)

\*2 External static pressure option is available (30Pa, 60Pa / 3.1mmH<sub>2</sub>O, 6.1mmH<sub>2</sub>O).

\*Due to continuing improvement, above specifications may be subject to change without notice.

OUTDOOR UNIT

## YKD-series - Cooling-only High Efficiency

## PUCY-EP YSKD (-BS)



Advantages of CITY MULTI

Outdoor/Heat source unit

Indoor unit

Remote Controller

Lossnay

Installation information

## Specifications

Model			PUCY-EP1050YSKD (-BS)	PUCY-EP1100YSKD (-BS)
Power source			3-phase 4-wire 380-400-415 V 50/60 Hz	
Cooling capacity (Nominal)	*1	kW	120.0	124.0
		BTU/h	409,400	423,100
	Power input	kW	29.62	32.37
	Current input	A	50.0-47.5-45.7	54.6-51.9-50.0
	EER	kW/kW	4.05	3.83
Temp. range of cooling	Indoor	W.B.	15.0~24.0 °C (59~75 °F)	15.0~24.0 °C (59~75 °F)
	Outdoor	D.B.	10.0~52.0 °C (50~126 °F)	10.0~52.0 °C (50~126 °F)
Indoor unit connectable	Total capacity		50~130% of outdoor unit capacity	50~130% of outdoor unit capacity
	Model/Quantity		P15~P600/1~50	P15~P600/1~50
Sound pressure level (measured in anechoic room)		dB <A>	66	67
Refrigerant piping diameter		Liquid pipe	19.05 (3/4) Brazed	19.05 (3/4) Brazed
		Gas pipe	41.28 (1-5/8) Brazed	41.28 (1-5/8) Brazed

## Set Model

Model			PUCY-P350YKD (-BS)	PUCY-P350YKD (-BS)	PUCY-P350YKD (-BS)	PUCY-P350YKD (-BS)	PUCY-P350YKD (-BS)	PUCY-P400YKD (-BS)
Fan	Type x Quantity		Propeller fan x 1			Propeller fan x 1		
	Air flow rate	m <sup>3</sup> /min	210	210	210	210	210	210
		L/s	3,500	3,500	3,500	3,500	3,500	3,500
		cfm	7,415	7,415	7,415	7,415	7,415	7,415
	Control, Driving mechanism		Inverter-control, Direct-driven by motor			Inverter-control, Direct-driven by motor		
*2	Motor output	kW	0.92 x 1	0.92 x 1	0.92 x 1	0.92 x 1	0.92 x 1	
	External static press.		0 Pa (0 mmH <sub>2</sub> O)	0 Pa (0 mmH <sub>2</sub> O)	0 Pa (0 mmH <sub>2</sub> O)	0 Pa (0 mmH <sub>2</sub> O)	0 Pa (0 mmH <sub>2</sub> O)	
Compressor	Type		Inverter scroll hermetic compressor			Inverter scroll hermetic compressor		
	Starting method		Inverter	Inverter	Inverter	Inverter	Inverter	
	Motor output	kW	10.4	10.4	10.4	10.4	10.4	
	Case heater	kW	-	-	-	-	-	
External finish		Pre-coated galvanized steel sheets (+powder coating for -BS type) <MUNSELL 3Y 7.8/1.1 or similar>			Pre-coated galvanized steel sheets (+powder coating for -BS type) <MUNSELL 3Y 7.8/1.1 or similar>			
External dimension H x W x D		mm	1,650 x 1,220 x 740	1,650 x 1,220 x 740	1,650 x 1,220 x 740	1,650 x 1,220 x 740	1,650 x 1,220 x 740	
		in.	65 x 48-1/16 x 29-3/16	65 x 48-1/16 x 29-3/16	65 x 48-1/16 x 29-3/16	65 x 48-1/16 x 29-3/16	65 x 48-1/16 x 29-3/16	
Protection devices	High pressure protection		High pressure sensor, High pressure switch at 4.15 MPa (601 psi)			High pressure sensor, High pressure switch at 4.15 MPa (601 psi)		
	Inverter circuit (COMP./FAN)		Over-heat protection, Over-current protection			Over-heat protection, Over-current protection		
Refrigerant	Type x original charge	R410A x 11.5 kg (26 lbs)	R410A x 11.5 kg (26 lbs)	R410A x 11.5 kg (26 lbs)	R410A x 11.5 kg (26 lbs)	R410A x 11.5 kg (26 lbs)	R410A x 11.5 kg (26 lbs)	
Net weight	kg (lbs)	236 (521)	236 (521)	236 (521)	236 (521)	236 (521)	236 (521)	
Heat exchanger		Salt-resistant cross fin & copper tube			Salt-resistant cross fin & copper tube			
Pipe between unit and distributor	Liquid pipe	mm (in.)	12.7 (1/2) Brazed	12.7 (1/2) Brazed	12.7 (1/2) Brazed	12.7 (1/2) Brazed	15.88 (5/8) Brazed	
	Gas pipe	mm (in.)	28.58 (1-1/8) Brazed	28.58 (1-1/8) Brazed	28.58 (1-1/8) Brazed	28.58 (1-1/8) Brazed	28.58 (1-1/8) Brazed	
Optional parts		Outdoor Twinning kit: CMY-Y300VBK3 Joint: CMY-Y102SS/LS-G2, CMY-Y202/302S-G2 Header: CMY-Y104/108/1010-G			Outdoor Twinning kit: CMY-Y300VBK3 Joint: CMY-Y102SS/LS-G2, CMY-Y202/302S-G2 Header: CMY-Y104/108/1010-G			

## Notes:

\*1 Nominal cooling conditions (subject to JIS B8615-2)

	Indoor	Outdoor	Pipe length	Level difference
Cooling	27 °CD.B./19 °CW.B. (81 °FD.B./66 °FW.B.)	35 °CD.B. (95 °FD.B.)	7.5 m (24-9/16 ft.)	0 m (0 ft.)

\*2 External static pressure option is available (30Pa, 60Pa / 3.1mmH<sub>2</sub>O, 6.1mmH<sub>2</sub>O).

\*Due to continuing improvement, above specifications may be subject to change without notice.

OUTDOOR UNIT  
**YKD-series**

# PUHY-P YKD (-BS)



## Specifications

Model		PUHY-P200YKD (-BS)	PUHY-P250YKD (-BS)	PUHY-P300YKD (-BS)	PUHY-P350YKD (-BS)	
Power source		3-phase 4-wire 380-400-415 V 50/60 Hz	3-phase 4-wire 380-400-415 V 50/60 Hz	3-phase 4-wire 380-400-415 V 50/60 Hz	3-phase 4-wire 380-400-415 V 50/60 Hz	
Cooling capacity (Nominal)	*1 kW	22.4	28.0	33.5	40.0	
	BTU/h	76,400	95,500	114,300	136,500	
	Power input kW	4.48	5.88	7.59	9.66	
	Current input A	7.5-7.1-6.9	9.9-9.4-9.0	12.8-12.1-11.7	16.3-15.4-14.9	
EER		5.00	4.76	4.41	4.14	
Temp. range of cooling	Indoor	W.B. 15.0~24.0 °C (59~75 °F)	15.0~24.0 °C (59~75 °F)	15.0~24.0 °C (59~75 °F)	15.0~24.0 °C (59~75 °F)	
	Outdoor	D.B. -5.0~52.0 °C (23~126 °F)	-5.0~52.0 °C (23~126 °F)	-5.0~52.0 °C (23~126 °F)	-5.0~52.0 °C (23~126 °F)	
Heating capacity (Nominal)	*2 kW	22.4	28.0	33.5	40.0	
	BTU/h	76,400	95,500	114,300	136,500	
	Power input kW	5.05	6.33	8.11	9.61	
	Current input A	8.5-8.0-7.8	10.6-10.1-9.7	13.6-13.0-12.5	16.2-15.4-14.8	
COP		4.43	4.42	4.13	4.16	
Temp. range of heating	Indoor	D.B. 15.0~27.0 °C (59~81 °F)	15.0~27.0 °C (59~81 °F)	15.0~27.0 °C (59~81 °F)	15.0~27.0 °C (59~81 °F)	
	Outdoor	W.B. -20.0~15.5 °C (-4~60 °F)	-20.0~15.5 °C (-4~60 °F)	-20.0~15.5 °C (-4~60 °F)	-20.0~15.5 °C (-4~60 °F)	
Indoor unit connectable	Total capacity	50~130% of outdoor unit capacity	50~130% of outdoor unit capacity	50~130% of outdoor unit capacity	50~130% of outdoor unit capacity	
	Model/Quantity	P15~P250/1~17	P15~P250/1~21	P15~P300/1~26	P15~P300/1~30	
Sound pressure level (measured in anechoic room)	dB <A>	57	58	61	61	
Refrigerant piping diameter	Liquid pipe	mm (in.) 9.52 (3/8) Brazed	9.52 (3/8) Brazed (12.7 (1/2) Brazed, farthest length >= 90 m)	9.52 (3/8) Brazed (12.7 (1/2) Brazed, farthest length >= 40 m)	12.7 (1/2) Brazed	
	Gas pipe	mm (in.) 22.2 (7/8) Brazed	22.2 (7/8) Brazed	22.2 (7/8) Brazed	28.58 (1-1/8) Brazed	
Fan	Type x Quantity	Propeller fan x 1	Propeller fan x 1	Propeller fan x 1	Propeller fan x 1	
	Air flow rate	m <sup>3</sup> /min	175	175	185	210
		L/s	2,917	2,917	3,083	3,500
		cfm	6,179	6,179	6,532	7,415
	Control, Driving mechanism	Inverter-control, Direct-driven by motor	Inverter-control, Direct-driven by motor	Inverter-control, Direct-driven by motor	Inverter-control, Direct-driven by motor	
	Motor output	0.92 x 1	0.92 x 1	0.92 x 1	0.92 x 1	
*3 External static press.	0 Pa (0 mmH <sub>2</sub> O)	0 Pa (0 mmH <sub>2</sub> O)	0 Pa (0 mmH <sub>2</sub> O)	0 Pa (0 mmH <sub>2</sub> O)		
Compressor	Type	Inverter scroll hermetic compressor	Inverter scroll hermetic compressor	Inverter scroll hermetic compressor	Inverter scroll hermetic compressor	
	Starting method	Inverter	Inverter	Inverter	Inverter	
	Motor output	5.5	6.9	8.1	10.4	
Case heater	kW	-	-	-	-	
External finish		Pre-coated galvanized steel sheets (+powder coating for -BS type) <MUNSELL 3Y 7.8/1.1 or similar>	Pre-coated galvanized steel sheets (+powder coating for -BS type) <MUNSELL 3Y 7.8/1.1 or similar>	Pre-coated galvanized steel sheets (+powder coating for -BS type) <MUNSELL 3Y 7.8/1.1 or similar>	Pre-coated galvanized steel sheets (+powder coating for -BS type) <MUNSELL 3Y 7.8/1.1 or similar>	
External dimension H x W x D	mm	1,650 x 920 x 740	1,650 x 920 x 740	1,650 x 920 x 740	1,650 x 1,220 x 740	
	in.	65 x 36-1/4 x 29-3/16	65 x 36-1/4 x 29-3/16	65 x 36-1/4 x 29-3/16	65 x 48-1/16 x 29-3/16	
Protection devices	High pressure protection	High pressure sensor, High pressure switch at 4.15 MPa (601 psi)	High pressure sensor, High pressure switch at 4.15 MPa (601 psi)	High pressure sensor, High pressure switch at 4.15 MPa (601 psi)	High pressure sensor, High pressure switch at 4.15 MPa (601 psi)	
	Inverter circuit (COMP./FAN)	Over-heat protection, Over-current protection	Over-heat protection, Over-current protection	Over-heat protection, Over-current protection	Over-heat protection, Over-current protection	
Refrigerant	Type x original charge	R410A x 8.0 kg (18 lbs)	R410A x 8.0 kg (18 lbs)	R410A x 8.0 kg (18 lbs)	R410A x 11.5 kg (26 lbs)	
Net weight	kg (lbs)	191 (422)	191 (422)	204 (450)	243 (536)	
Heat exchanger		Salt-resistant cross fin & copper tube	Salt-resistant cross fin & copper tube	Salt-resistant cross fin & aluminium tube	Salt-resistant cross fin & copper tube	
Optional parts		Joint: CMY-Y102SS/LS-G2 Header: CMY-Y104/108/1010-G	Joint: CMY-Y102SS/LS-G2 Header: CMY-Y104/108/1010-G	Joint: CMY-Y102SS/LS-G2 Header: CMY-Y104/108/1010-G	Joint: CMY-Y102SS/LS-G2, CMY-Y202S-G2 Header: CMY-Y104/108/1010-G	

### Notes:

\*1,\*2 Nominal conditions

	Indoor	Outdoor	Pipe length	Level difference
Cooling	27 °CD.B./19 °CW.B. (81 °FD.B./66 °FW.B.)	35 °CD.B. (95 °FD.B.)	7.5 m (24-9/16 ft.)	0 m (0 ft.)
Heating	20 °CD.B. (68 °FD.B.)	7 °CD.B./6 °CW.B. (45 °FD.B./43 °FW.B.)	7.5 m (24-9/16 ft.)	0 m (0 ft.)

\*3 External static pressure option is available (30Pa, 60Pa / 3.1mmH<sub>2</sub>O, 6.1mmH<sub>2</sub>O).

\*Nominal condition \*1,\*2 are subject to JIS B8615-2.

\*Due to continuing improvement, above specifications may be subject to change without notice.

OUTDOOR UNIT  
**YKD-series**

# PUHY-P YKD (-BS)



Advantages of CITY MULTI

Outdoor/Heat source unit

Indoor unit

Remote Controller

Lossnay

Installation information

## Specifications

Model	PUHY-P400YKD (-BS)		PUHY-P450YKD (-BS)		PUHY-P500YKD (-BS)		
Power source	3-phase 4-wire 380-400-415 V 50/60 Hz		3-phase 4-wire 380-400-415 V 50/60 Hz		3-phase 4-wire 380-400-415 V 50/60 Hz		
Cooling capacity (Nominal)	*1	kW	45.0	48.0	55.0		
		BTU/h	153,500	163,800	187,700		
	Power input	kW	12.71	14.32	16.22		
		Current input	A	21.4-20.3-19.6	24.1-22.9-22.1	27.3-26.0-25.0	
		EER	kW/kW	3.54	3.35	3.39	
Temp. range of cooling	Indoor	W.B.	15.0~24.0 °C (59~75 °F)	15.0~24.0 °C (59~75 °F)	15.0~24.0 °C (59~75 °F)		
	Outdoor	D.B.	-5.0~52.0 °C (23~126 °F)	-5.0~52.0 °C (23~126 °F)	-5.0~52.0 °C (23~126 °F)		
Heating capacity (Nominal)	*2	kW	45.0	48.0	55.0		
		BTU/h	153,500	163,800	187,700		
	Power input	kW	10.92	13.33	15.71		
		Current input	A	18.4-17.5-16.8	22.5-21.3-20.6	26.5-25.1-24.2	
		COP	kW/kW	4.12	3.60	3.50	
Temp. range of heating	Indoor	D.B.	15.0~27.0 °C (59~81 °F)	15.0~27.0 °C (59~81 °F)	15.0~27.0 °C (59~81 °F)		
	Outdoor	W.B.	-20.0~15.5 °C (-4~60 °F)	-20.0~15.5 °C (-4~60 °F)	-20.0~15.5 °C (-4~60 °F)		
Indoor unit connectable	Total capacity	50~130% of outdoor unit capacity		50~130% of outdoor unit capacity			
	Model/Quantity	P15~P400/1~34		P15~P400/1~39			
Sound pressure level (measured in anechoic room)	dB <A>	63	63	65			
Refrigerant piping diameter	Liquid pipe	mm (in.)	12.7 (1/2) Brazed	15.88 (5/8) Brazed	15.88 (5/8) Brazed		
	Gas pipe	mm (in.)	28.58 (1-1/8) Brazed	28.58 (1-1/8) Brazed	28.58 (1-1/8) Brazed		
Fan	Type x Quantity	Propeller fan x 1		Propeller fan x 1			
	Air flow rate	m <sup>3</sup> /min	210	210	360		
		L/s	3,500	3,500	6,000		
		cfm	7,415	7,415	12,712		
	Control, Driving mechanism	Inverter-control, Direct-driven by motor		Inverter-control, Direct-driven by motor		Inverter-control, Direct-driven by motor	
	Motor output	kW	0.92 x 1	0.92 x 1	0.92 x 2		
	*3 External static press.	0 Pa (0 mmH <sub>2</sub> O)		0 Pa (0 mmH <sub>2</sub> O)		0 Pa (0 mmH <sub>2</sub> O)	
Compressor	Type	Inverter scroll hermetic compressor		Inverter scroll hermetic compressor		Inverter scroll hermetic compressor	
	Starting method	Inverter		Inverter		Inverter	
	Motor output	kW	10.8	12.4	13.3		
	Case heater	kW	-	-	-		
External finish	Pre-coated galvanized steel sheets (+powder coating for -BS type) <MUNSELL 3Y 7.8/1.1 or similar>		Pre-coated galvanized steel sheets (+powder coating for -BS type) <MUNSELL 3Y 7.8/1.1 or similar>		Pre-coated galvanized steel sheets (+powder coating for -BS type) <MUNSELL 3Y 7.8/1.1 or similar>		
External dimension H x W x D	mm	1,650 x 1,220 x 740	1,650 x 1,220 x 740	1,650 x 1,750 x 740			
	in.	65 x 48-1/16 x 29-3/16	65 x 48-1/16 x 29-3/16	65 x 68-15/16 x 29-3/16			
Protection devices	High pressure protection	High pressure sensor, High pressure switch at 4.15 MPa (601 psi)	High pressure sensor, High pressure switch at 4.15 MPa (601 psi)	High pressure sensor, High pressure switch at 4.15 MPa (601 psi)			
	Inverter circuit (COMP./FAN)	Over-heat protection, Over-current protection	Over-heat protection, Over-current protection	Over-heat protection, Over-current protection			
Refrigerant	Type x original charge	R410A x 11.5 kg (26 lbs)		R410A x 11.5 kg (26 lbs)		R410A x 11.8 kg (27 lbs)	
Net weight	kg (lbs)	241 (532)		241 (532)		285 (629)	
Heat exchanger	Salt-resistant cross fin & copper tube		Salt-resistant cross fin & copper tube		Salt-resistant cross fin & copper tube		
Optional parts	Joint: CMY-Y102SS/LS-G2, CMY-Y202S-G2 Header: CMY-Y104/108/1010-G		Joint: CMY-Y102SS/LS-G2, CMY-Y202S-G2 Header: CMY-Y104/108/1010-G		Joint: CMY-Y102SS/LS-G2, CMY-Y202S-G2 Header: CMY-Y104/108/1010-G		

### Notes:

\*1,\*2 Nominal conditions

	Indoor	Outdoor	Pipe length	Level difference
Cooling	27 °CD.B./19 °CW.B. (81 °FD.B./66 °FW.B.)	35 °CD.B. (95 °FD.B.)	7.5 m (24-9/16 ft.)	0 m (0 ft.)
Heating	20 °CD.B. (68 °FD.B.)	7 °CD.B./6 °CW.B. (45 °FD.B./43 °FW.B.)	7.5 m (24-9/16 ft.)	0 m (0 ft.)

\*3 External static pressure option is available (30Pa, 60Pa / 3.1mmH<sub>2</sub>O, 6.1mmH<sub>2</sub>O).

\*Nominal condition \*1,\*2 are subject to JIS B8615-2.

\*Due to continuing improvement, above specifications may be subject to change without notice.



OUTDOOR UNIT  
**YKD-series**

# PUHY-P YSKD (-BS)



## Specifications

Model	PUHY-P550YSKD (-BS)		PUHY-P600YSKD (-BS)		PUHY-P650YSKD (-BS)			
Power source	3-phase 4-wire 380-400-415 V 50/60 Hz		3-phase 4-wire 380-400-415 V 50/60 Hz		3-phase 4-wire 380-400-415 V 50/60 Hz			
Cooling capacity (Nominal)	*1	kW	63.0	68.0	73.0			
		BTU/h	215,000	232,000	249,100			
	Power input	kW	14.25	15.34	17.80			
	Current input	A	24.0-22.8-22.0	25.8-24.6-23.7	30.0-28.5-27.5			
	EER	kW/kW	4.42	4.43	4.10			
Temp. range of cooling	Indoor	W.B.	15.0~24.0 °C (59~75 °F)	15.0~24.0 °C (59~75 °F)	15.0~24.0 °C (59~75 °F)			
	Outdoor	D.B.	-5.0~52.0 °C (23~126 °F)	-5.0~52.0 °C (23~126 °F)	-5.0~52.0 °C (23~126 °F)			
Heating capacity (Nominal)	*2	kW	63.0	68.0	73.0			
		BTU/h	215,000	232,000	249,100			
	Power input	kW	15.51	16.70	18.02			
	Current input	A	26.1-24.8-23.9	28.1-26.7-25.8	30.4-28.8-27.8			
	COP	kW/kW	4.06	4.07	4.05			
Temp. range of heating	Indoor	D.B.	15.0~27.0 °C (59~81 °F)	15.0~27.0 °C (59~81 °F)	15.0~27.0 °C (59~81 °F)			
	Outdoor	W.B.	-20.0~15.5 °C (-4~60 °F)	-20.0~15.5 °C (-4~60 °F)	-20.0~15.5 °C (-4~60 °F)			
Indoor unit connectable	Total capacity	50~130% of outdoor unit capacity		50~130% of outdoor unit capacity		50~130% of outdoor unit capacity		
	Model/Quantity	P15-P500/1~47		P15-P600/1~50		P15-P600/1~50		
Sound pressure level (measured in anechoic room)	dB <A>	63		63		64.5		
Refrigerant piping diameter	Liquid pipe	mm (in.)	15.88 (5/8) Brazed		15.88 (5/8) Brazed		15.88 (5/8) Brazed	
	Gas pipe	mm (in.)	28.58 (1-1/8) Brazed		28.58 (1-1/8) Brazed		28.58 (1-1/8) Brazed	

### Set Model

Model	PUHY-P250YKD (-BS)		PUHY-P300YKD (-BS)		PUHY-P250YKD (-BS)		PUHY-P350YKD (-BS)		PUHY-P250YKD (-BS)		PUHY-P400YKD (-BS)			
Fan	Type x Quantity	Propeller fan x 1		Propeller fan x 1		Propeller fan x 1		Propeller fan x 1		Propeller fan x 1		Propeller fan x 1		
	Air flow rate	m <sup>3</sup> /min	175	185	175	210	175	210	175	210	175	210	175	210
		L/s	2,917	3,083	2,917	3,500	2,917	3,500	2,917	3,500	2,917	3,500	2,917	3,500
		cfm	6,179	6,532	6,179	7,415	6,179	7,415	6,179	7,415	6,179	7,415	6,179	7,415
	Control, Driving mechanism	Inverter-control, Direct-driven by motor				Inverter-control, Direct-driven by motor				Inverter-control, Direct-driven by motor				
Motor output	kW	0.92 x 1		0.92 x 1		0.92 x 1		0.92 x 1		0.92 x 1		0.92 x 1		
*3 External static press.	0 Pa (0 mmH <sub>2</sub> O)		0 Pa (0 mmH <sub>2</sub> O)		0 Pa (0 mmH <sub>2</sub> O)		0 Pa (0 mmH <sub>2</sub> O)		0 Pa (0 mmH <sub>2</sub> O)		0 Pa (0 mmH <sub>2</sub> O)			
Compressor	Type	Inverter scroll hermetic compressor		Inverter scroll hermetic compressor		Inverter scroll hermetic compressor		Inverter scroll hermetic compressor		Inverter scroll hermetic compressor		Inverter scroll hermetic compressor		
	Starting method	Inverter		Inverter		Inverter		Inverter		Inverter		Inverter		
	Motor output	kW	6.9	8.1	6.9	10.4	6.9	10.8	6.9	10.8	6.9	10.8		
	Case heater	kW	-		-		-		-		-		-	
External finish	Pre-coated galvanized steel sheets (+powder coating for -BS type) <MUNSELL 3Y 7.8/1.1 or similar>				Pre-coated galvanized steel sheets (+powder coating for -BS type) <MUNSELL 3Y 7.8/1.1 or similar>				Pre-coated galvanized steel sheets (+powder coating for -BS type) <MUNSELL 3Y 7.8/1.1 or similar>					
External dimension H x W x D	mm	1,650 x 920 x 740	1,650 x 920 x 740	1,650 x 920 x 740	1,650 x 1,220 x 740	1,650 x 920 x 740	1,650 x 1,220 x 740	1,650 x 920 x 740	1,650 x 1,220 x 740	1,650 x 920 x 740	1,650 x 1,220 x 740	1,650 x 920 x 740	1,650 x 1,220 x 740	
	in.	65 x 36-1/4 x 29-3/16	65 x 36-1/4 x 29-3/16	65 x 36-1/4 x 29-3/16	65 x 48-1/16 x 29-3/16	65 x 36-1/4 x 29-3/16	65 x 48-1/16 x 29-3/16	65 x 36-1/4 x 29-3/16	65 x 48-1/16 x 29-3/16	65 x 36-1/4 x 29-3/16	65 x 48-1/16 x 29-3/16	65 x 36-1/4 x 29-3/16	65 x 48-1/16 x 29-3/16	
Protection devices	High pressure protection	High pressure sensor, High pressure switch at 4.15 MPa (601 psi)				High pressure sensor, High pressure switch at 4.15 MPa (601 psi)				High pressure sensor, High pressure switch at 4.15 MPa (601 psi)				
	Inverter circuit (COMP./FAN)	Over-heat protection, Over-current protection				Over-heat protection, Over-current protection				Over-heat protection, Over-current protection				
Refrigerant	Type x original charge	R410A x 8.0 kg (18 lbs)	R410A x 8.0 kg (18 lbs)	R410A x 8.0 kg (18 lbs)	R410A x 11.5 kg (26 lbs)	R410A x 8.0 kg (18 lbs)	R410A x 11.5 kg (26 lbs)	R410A x 8.0 kg (18 lbs)	R410A x 11.5 kg (26 lbs)	R410A x 8.0 kg (18 lbs)	R410A x 11.5 kg (26 lbs)	R410A x 8.0 kg (18 lbs)	R410A x 11.5 kg (26 lbs)	
Net weight	kg (lbs)	191 (422)	204 (450)	191 (422)	243 (536)	191 (422)	241 (532)	191 (422)	241 (532)	191 (422)	241 (532)	191 (422)	241 (532)	
Heat exchanger	Salt-resistant cross fin & copper tube													
Pipe between unit and distributor	Liquid pipe	mm (in.)	9.52 (3/8) Brazed	12.7 (1/2) Brazed	9.52 (3/8) Brazed	12.7 (1/2) Brazed	9.52 (3/8) Brazed	15.88 (5/8) Brazed	9.52 (3/8) Brazed	15.88 (5/8) Brazed	9.52 (3/8) Brazed	15.88 (5/8) Brazed		
	Gas pipe	mm (in.)	22.2 (7/8) Brazed	22.2 (7/8) Brazed	22.2 (7/8) Brazed	28.58 (1-1/8) Brazed	22.2 (7/8) Brazed	28.58 (1-1/8) Brazed	22.2 (7/8) Brazed	28.58 (1-1/8) Brazed	22.2 (7/8) Brazed	28.58 (1-1/8) Brazed		
Optional parts	Outdoor Twinning kit: CMY-Y100VBK3 Joint: CMY-Y102SS/LS-G2, CMY-Y202S/302S-G2 Header: CMY-Y104/108/1010-G				Outdoor Twinning kit: CMY-Y100VBK3 Joint: CMY-Y102SS/LS-G2, CMY-Y202S/302S-G2 Header: CMY-Y104/108/1010-G				Outdoor Twinning kit: CMY-Y100VBK3 Joint: CMY-Y102SS/LS-G2, CMY-Y202S/302S-G2 Header: CMY-Y104/108/1010-G					

### Notes:

\*1,\*2 Nominal conditions

	Indoor	Outdoor	Pipe length	Level difference
Cooling	27 °CD.B./19 °CW.B. (81 °FD.B./66 °FW.B.)	35 °CD.B. (95 °FD.B.)	7.5 m (24-9/16 ft.)	0 m (0 ft.)
Heating	20 °CD.B. (68 °FD.B.)	7 °CD.B./6 °CW.B. (45 °FD.B./43 °FW.B.)	7.5 m (24-9/16 ft.)	0 m (0 ft.)

\*3 External static pressure option is available (30Pa / 3.1mmH<sub>2</sub>O, 6.1mmH<sub>2</sub>O).

\*Nominal condition \*1,\*2 are subject to JIS B8615-2.

\*Due to continuing improvement, above specifications may be subject to change without notice.

## OUTDOOR UNIT

## YKD-series

## PUHY-P YSKD (-BS)



Advantages of CITY MULTI

Outdoor/Heat source unit

Indoor unit

Remote Controller

Lossnay

Installation information

## Specifications

Model	PUHY-P700YSKD (-BS)		PUHY-P750YSKD (-BS)		PUHY-P800YSKD (-BS)		
Power source	3-phase 4-wire 380-400-415 V 50/60 Hz		3-phase 4-wire 380-400-415 V 50/60 Hz		3-phase 4-wire 380-400-415 V 50/60 Hz		
Cooling capacity (Nominal)	*1	kW	76.0	81.5	90.0	90.0	
		BTU/h	259,300	278,100	307,100	307,100	
		Power input kW	19.24	21.39	25.56	25.56	
		Current input A	32.4-30.8-29.7	36.1-34.3-33.0	43.1-40.9-39.5	43.1-40.9-39.5	
Temp. range of cooling		EER	3.95	3.81	3.52	3.52	
	Indoor	W.B.	15.0~24.0 °C (59~75 °F)	15.0~24.0 °C (59~75 °F)	15.0~24.0 °C (59~75 °F)	15.0~24.0 °C (59~75 °F)	
	Outdoor	D.B.	-5.0~52.0 °C (23~126 °F)	-5.0~52.0 °C (23~126 °F)	-5.0~52.0 °C (23~126 °F)	-5.0~52.0 °C (23~126 °F)	
Heating capacity (Nominal)	*2	kW	76.0	81.5	90.0	90.0	
		BTU/h	259,300	278,100	307,100	307,100	
		Power input kW	20.00	22.20	23.01	23.01	
		Current input A	33.7-32.0-30.9	37.4-35.6-34.3	38.8-36.9-35.5	38.8-36.9-35.5	
Temp. range of heating		COP	3.80	3.67	3.91	3.91	
	Indoor	D.B.	15.0~27.0 °C (59~81 °F)	15.0~27.0 °C (59~81 °F)	15.0~27.0 °C (59~81 °F)	15.0~27.0 °C (59~81 °F)	
	Outdoor	W.B.	-20.0~15.5 °C (-4~60 °F)	-20.0~15.5 °C (-4~60 °F)	-20.0~15.5 °C (-4~60 °F)	-20.0~15.5 °C (-4~60 °F)	
Indoor unit connectable	Total capacity	50~130% of outdoor unit capacity		50~130% of outdoor unit capacity		50~130% of outdoor unit capacity	
	Model/Quantity	P15~P600/1~50		P15~P600/1~50		P15~P600/1~50	
Sound pressure level (measured in anechoic room)	dB <A>	64.5		65.5		66	
Refrigerant piping diameter	Liquid pipe	19.05 (3/4) Brazed		19.05 (3/4) Brazed		19.05 (3/4) Brazed	
	Gas pipe	34.93 (1-3/8) Brazed		34.93 (1-3/8) Brazed		34.93 (1-3/8) Brazed	

## Set Model

Model	PUHY-P250YKD (-BS)		PUHY-P450YKD (-BS)		PUHY-P300YKD (-BS)		PUHY-P450YKD (-BS)		PUHY-P400YKD (-BS)		PUHY-P400YKD (-BS)			
Fan	Type x Quantity	Propeller fan x 1		Propeller fan x 1		Propeller fan x 1		Propeller fan x 1		Propeller fan x 1		Propeller fan x 1		
	Air flow rate	m <sup>3</sup> /min	175		210		185		210		210		210	
		L/s	2,917		3,500		3,083		3,500		3,500		3,500	
		cfm	6,179		7,415		6,532		7,415		7,415		7,415	
	Control, Driving mechanism	Inverter-control, Direct-driven by motor				Inverter-control, Direct-driven by motor				Inverter-control, Direct-driven by motor				
	Motor output	0.92 x 1		0.92 x 1		0.92 x 1		0.92 x 1		0.92 x 1		0.92 x 1		
Compressor	*3 External static press.	0 Pa (0 mmH <sub>2</sub> O)		0 Pa (0 mmH <sub>2</sub> O)		0 Pa (0 mmH <sub>2</sub> O)		0 Pa (0 mmH <sub>2</sub> O)		0 Pa (0 mmH <sub>2</sub> O)		0 Pa (0 mmH <sub>2</sub> O)		
	Type	Inverter scroll hermetic compressor				Inverter scroll hermetic compressor				Inverter scroll hermetic compressor				
	Starting method	Inverter		Inverter		Inverter		Inverter		Inverter		Inverter		
	Motor output	6.9		12.4		8.1		12.4		10.8		10.8		
	Case heater	-		-		-		-		-		-		
	External finish	Pre-coated galvanized steel sheets (+powder coating for -BS type) <MUNSELL 3Y 7.8/1.1 or similar>				Pre-coated galvanized steel sheets (+powder coating for -BS type) <MUNSELL 3Y 7.8/1.1 or similar>				Pre-coated galvanized steel sheets (+powder coating for -BS type) <MUNSELL 3Y 7.8/1.1 or similar>				
External dimension H x W x D	mm	1,650 x 920 x 740		1,650 x 1,220 x 740		1,650 x 920 x 740		1,650 x 1,220 x 740		1,650 x 1,220 x 740		1,650 x 1,220 x 740		
	in.	65 x 36-1/4 x 29-3/16		65 x 48-1/16 x 29-3/16		65 x 36-1/4 x 29-3/16		65 x 48-1/16 x 29-3/16		65 x 48-1/16 x 29-3/16		65 x 48-1/16 x 29-3/16		
Protection devices	High pressure protection	High pressure sensor, High pressure switch at 4.15 MPa (601 psi)				High pressure sensor, High pressure switch at 4.15 MPa (601 psi)				High pressure sensor, High pressure switch at 4.15 MPa (601 psi)				
	Inverter circuit (COMP./FAN)	Over-heat protection, Over-current protection				Over-heat protection, Over-current protection				Over-heat protection, Over-current protection				
Refrigerant	Type x original charge	R410A x 8.0 kg (18 lbs)		R410A x 11.5 kg (26 lbs)		R410A x 8.0 kg (18 lbs)		R410A x 11.5 kg (26 lbs)		R410A x 11.5 kg (26 lbs)		R410A x 11.5 kg (26 lbs)		
Net weight	kg (lbs)	191 (422)		241 (532)		204 (450)		241 (532)		241 (532)		241 (532)		
Heat exchanger		Salt-resistant cross fin & copper tube				Salt-resistant cross fin & copper tube				Salt-resistant cross fin & copper tube				
Pipe between unit and distributor	Liquid pipe	9.52 (3/8) Brazed		15.88 (5/8) Brazed		12.7 (1/2) Brazed		15.88 (5/8) Brazed		15.88 (5/8) Brazed		15.88 (5/8) Brazed		
	Gas pipe	22.2 (7/8) Brazed		28.58 (1-1/8) Brazed		22.2 (7/8) Brazed		28.58 (1-1/8) Brazed		28.58 (1-1/8) Brazed		28.58 (1-1/8) Brazed		
Optional parts		Outdoor Twinning kit: CMY-Y200VBK2 Joint: CMY-Y102SS/LS-G2, CMY-Y202S/302S-G2 Header: CMY-Y104/108/1010-G				Outdoor Twinning kit: CMY-Y200VBK2 Joint: CMY-Y102SS/LS-G2, CMY-Y202S/302S-G2 Header: CMY-Y104/108/1010-G				Outdoor Twinning kit: CMY-Y200VBK2 Joint: CMY-Y102SS/LS-G2, CMY-Y202S/302S-G2 Header: CMY-Y104/108/1010-G				

## Notes:

\*1,\*2 Nominal conditions

	Indoor	Outdoor	Pipe length	Level difference
Cooling	27 °CD.B./19 °CW.B. (81 °FD.B./66 °FW.B.)	35 °CD.B. (95 °FD.B.)	7.5 m (24-9/16 ft.)	0 m (0 ft.)
Heating	20 °CD.B. (68 °FD.B.)	7 °CD.B./6 °CW.B. (45 °FD.B./43 °FW.B.)	7.5 m (24-9/16 ft.)	0 m (0 ft.)

\*3 External static pressure option is available (30Pa / 3.1mmH<sub>2</sub>O, 6.1mmH<sub>2</sub>O).

\*Nominal condition \*1,\*2 are subject to JIS B8615-2.

\*Due to continuing improvement, above specifications may be subject to change without notice.

OUTDOOR UNIT  
**YKD-series**

# PUHY-P YSKD (-BS)



## Specifications

Model		PUHY-P850YSKD (-BS)	PUHY-P900YSKD (-BS)	PUHY-P950YSKD (-BS)
Power source		3-phase 4-wire 380-400-415 V 50/60 Hz	3-phase 4-wire 380-400-415 V 50/60 Hz	3-phase 4-wire 380-400-415 V 50/60 Hz
Cooling capacity (Nominal)	*1 kW	93.0	96.0	103.0
	BTU/h	317,300	327,600	351,400
	Power input kW	27.27	29.00	31.30
	Current input A	46.0-43.7-42.1	48.9-46.5-44.8	52.8-50.1-48.3
	EER kW/kW	3.41	3.31	3.29
Temp. range of cooling	Indoor W.B.	15.0~24.0 °C (59~75 °F)	15.0~24.0 °C (59~75 °F)	15.0~24.0 °C (59~75 °F)
	Outdoor D.B.	-5.0~52.0 °C (23~126 °F)	-5.0~52.0 °C (23~126 °F)	-5.0~52.0 °C (23~126 °F)
Heating capacity (Nominal)	*2 kW	93.0	96.0	103.0
	BTU/h	317,300	327,600	351,400
	Power input kW	25.40	28.07	30.56
	Current input A	42.8-40.7-39.2	47.3-45.0-43.3	51.5-49.0-47.2
	COP kW/kW	3.66	3.42	3.37
Temp. range of heating	Indoor D.B.	15.0~27.0 °C (59~81 °F)	15.0~27.0 °C (59~81 °F)	15.0~27.0 °C (59~81 °F)
	Outdoor W.B.	-20.0~15.5 °C (-4~60 °F)	-20.0~15.5 °C (-4~60 °F)	-20.0~15.5 °C (-4~60 °F)
Indoor unit connectable	Total capacity	50~130% of outdoor unit capacity	50~130% of outdoor unit capacity	50~130% of outdoor unit capacity
	Model/Quantity	P15~P600/1~50	P15~P600/1~50	P15~P600/1~50
Sound pressure level (measured in anechoic room)	dB <A>	66	66	67.5
Refrigerant piping diameter	Liquid pipe mm (in.)	19.05 (3/4) Brazed	19.05 (3/4) Brazed	19.05 (3/4) Brazed
	Gas pipe mm (in.)	41.28 (1-5/8) Brazed	41.28 (1-5/8) Brazed	41.28 (1-5/8) Brazed

### Set Model

Model		PUHY-P400YKD (-BS)	PUHY-P450YKD (-BS)	PUHY-P450YKD (-BS)	PUHY-P450YKD (-BS)	PUHY-P450YKD (-BS)	PUHY-P500YKD (-BS)	
Fan	Type x Quantity	Propeller fan x 1	Propeller fan x 1	Propeller fan x 1	Propeller fan x 1	Propeller fan x 1	Propeller fan x 2	
	Air flow rate	m <sup>3</sup> /min	210	210	210	210	210	360
		L/s	3,500	3,500	3,500	3,500	3,500	6,000
		cfm	7,415	7,415	7,415	7,415	7,415	12,712
	Control, Driving mechanism	Inverter-control, Direct-driven by motor		Inverter-control, Direct-driven by motor		Inverter-control, Direct-driven by motor		
	Motor output kW	0.92 x 1	0.92 x 1	0.92 x 1	0.92 x 1	0.92 x 1	0.92 x 2	
*3 External static press.	0 Pa (0 mmH <sub>2</sub> O)	0 Pa (0 mmH <sub>2</sub> O)	0 Pa (0 mmH <sub>2</sub> O)	0 Pa (0 mmH <sub>2</sub> O)	0 Pa (0 mmH <sub>2</sub> O)	0 Pa (0 mmH <sub>2</sub> O)		
Compressor	Type	Inverter scroll hermetic compressor		Inverter scroll hermetic compressor		Inverter scroll hermetic compressor		
	Starting method	Inverter	Inverter	Inverter	Inverter	Inverter	Inverter	
	Motor output kW	10.8	12.4	12.4	12.4	12.4	13.3	
	Case heater kW	-	-	-	-	-	-	
External finish	Pre-coated galvanized steel sheets (+powder coating for -BS type) <MUNSELL 3Y 7.8/1.1 or similar>		Pre-coated galvanized steel sheets (+powder coating for -BS type) <MUNSELL 3Y 7.8/1.1 or similar>		Pre-coated galvanized steel sheets (+powder coating for -BS type) <MUNSELL 3Y 7.8/1.1 or similar>			
External dimension H x W x D	mm	1,650 x 1,220 x 740	1,650 x 1,220 x 740	1,650 x 1,220 x 740	1,650 x 1,220 x 740	1,650 x 1,220 x 740	1,650 x 1,750 x 740	
	in.	65 x 48-1/16 x 29-3/16	65 x 48-1/16 x 29-3/16	65 x 48-1/16 x 29-3/16	65 x 48-1/16 x 29-3/16	65 x 48-1/16 x 29-3/16	65 x 68-15/16 x 29-3/16	
Protection devices	High pressure protection	High pressure sensor, High pressure switch at 4.15 MPa (601 psi)		High pressure sensor, High pressure switch at 4.15 MPa (601 psi)		High pressure sensor, High pressure switch at 4.15 MPa (601 psi)		
	Inverter circuit (COMP./FAN)	Over-heat protection, Over-current protection		Over-heat protection, Over-current protection		Over-heat protection, Over-current protection		
Refrigerant	Type x original charge	R410A x 11.5 kg (26 lbs)	R410A x 11.5 kg (26 lbs)	R410A x 11.5 kg (26 lbs)	R410A x 11.5 kg (26 lbs)	R410A x 11.5 kg (26 lbs)	R410A x 11.8 kg (27 lbs)	
Net weight	kg (lbs)	241 (532)	241 (532)	241 (532)	241 (532)	241 (532)	285 (629)	
Heat exchanger		Salt-resistant cross fin & copper tube		Salt-resistant cross fin & copper tube		Salt-resistant cross fin & copper tube		
Pipe between unit and distributor	Liquid pipe mm (in.)	15.88 (5/8) Brazed	15.88 (5/8) Brazed	15.88 (5/8) Brazed	15.88 (5/8) Brazed	15.88 (5/8) Brazed	15.88 (5/8) Brazed	
	Gas pipe mm (in.)	28.58 (1-1/8) Brazed	28.58 (1-1/8) Brazed	28.58 (1-1/8) Brazed	28.58 (1-1/8) Brazed	28.58 (1-1/8) Brazed	28.58 (1-1/8) Brazed	
Optional parts		Outdoor Twinning kit: CMY-Y200VBK2 Joint: CMY-Y102SS/LS-G2, CMY-Y202S/302S-G2 Header: CMY-Y104/108/1010-G		Outdoor Twinning kit: CMY-Y200VBK2 Joint: CMY-Y102SS/LS-G2, CMY-Y202S/302S-G2 Header: CMY-Y104/108/1010-G		Outdoor Twinning kit: CMY-Y200VBK2 Joint: CMY-Y102SS/LS-G2, CMY-Y202S/302S-G2 Header: CMY-Y104/108/1010-G		

### Notes:

\*1,\*2 Nominal conditions

	Indoor	Outdoor	Pipe length	Level difference
Cooling	27 °CD.B./19 °CW.B. (81 °FD.B./66 °FW.B.)	35 °CD.B. (95 °FD.B.)	7.5 m (24-9/16 ft.)	0 m (0 ft.)
Heating	20 °CD.B. (68 °FD.B.)	7 °CD.B./6 °CW.B. (45 °FD.B./43 °FW.B.)	7.5 m (24-9/16 ft.)	0 m (0 ft.)

\*3 External static pressure option is available (30Pa / 3.1mmH<sub>2</sub>O, 6.1mmH<sub>2</sub>O).

\*Nominal condition \*1,\*2 are subject to JIS B8615-2.

\*Due to continuing improvement, above specifications may be subject to change without notice.

# OUTDOOR UNIT

## YKD-series

### PUHY-P YSKD (-BS)



## Specifications

Model	PUHY-P1000YSKD (-BS)		PUHY-P1050YSKD (-BS)		PUHY-P1100YSKD (-BS)		
Power source	3-phase 4-wire 380-400-415 V 50/60 Hz		3-phase 4-wire 380-400-415 V 50/60 Hz		3-phase 4-wire 380-400-415 V 50/60 Hz		
Cooling capacity (Nominal)	*1	kW	110.0	115.0	121.5	121.5	
		BTU/h	375,300	392,400	414,600	414,600	
	Power input	kW	33.63	29.26	30.83	30.83	
	Current input	A	56.7-53.9-51.9	49.3-46.9-45.2	52.0-49.4-47.6	52.0-49.4-47.6	
	EER	kW/kW	3.27	3.93	3.94	3.94	
Temp. range of cooling	Indoor	W.B.	15.0~24.0 °C (59~75 °F)	15.0~24.0 °C (59~75 °F)	15.0~24.0 °C (59~75 °F)	15.0~24.0 °C (59~75 °F)	
	Outdoor	D.B.	-5.0~52.0 °C (23~126 °F)	-5.0~52.0 °C (23~126 °F)	-5.0~52.0 °C (23~126 °F)	-5.0~52.0 °C (23~126 °F)	
Heating capacity (Nominal)	*2	kW	110.0	115.0	121.5	121.5	
		BTU/h	375,300	392,400	414,600	414,600	
	Power input	kW	33.13	31.50	33.80	33.80	
	Current input	A	55.9-53.1-51.2	53.1-50.5-48.6	57.0-54.2-52.2	57.0-54.2-52.2	
	COP	kW/kW	3.32	3.65	3.59	3.59	
Temp. range of heating	Indoor	D.B.	15.0~27.0 °C (59~81 °F)	15.0~27.0 °C (59~81 °F)	15.0~27.0 °C (59~81 °F)	15.0~27.0 °C (59~81 °F)	
	Outdoor	W.B.	-20.0~15.5 °C (-4~60 °F)	-20.0~15.5 °C (-4~60 °F)	-20.0~15.5 °C (-4~60 °F)	-20.0~15.5 °C (-4~60 °F)	
Indoor unit connectable	Total capacity	50~130% of outdoor unit capacity		50~130% of outdoor unit capacity		50~130% of outdoor unit capacity	
	Model/Quantity	P15~P600/1~50		P15~P600/1~50		P15~P600/1~50	
Sound pressure level (measured in anechoic room)	dB <A>	68		66.5		66.5	
Refrigerant piping diameter	Liquid pipe	mm (in.)	19.05 (3/4) Brazed	19.05 (3/4) Brazed	19.05 (3/4) Brazed	19.05 (3/4) Brazed	19.05 (3/4) Brazed
	Gas pipe	mm (in.)	41.28 (1-5/8) Brazed	41.28 (1-5/8) Brazed	41.28 (1-5/8) Brazed	41.28 (1-5/8) Brazed	41.28 (1-5/8) Brazed

### Set Model

Model	PUHY-P500YKD (-BS)		PUHY-P500YKD (-BS)		PUHY-P300YKD (-BS)	PUHY-P300YKD (-BS)	PUHY-P450YKD (-BS)	PUHY-P300YKD (-BS)	PUHY-P350YKD (-BS)	PUHY-P450YKD (-BS)	
Fan	Type x Quantity	Propeller fan x 2		Propeller fan x 2		Propeller fan x 1	Propeller fan x 1	Propeller fan x 1	Propeller fan x 1	Propeller fan x 1	
	Air flow rate	m <sup>3</sup> /min	360	360	185	185	210	185	210	210	
		L/s	6,000	6,000	3,083	3,083	3,500	3,083	3,500	3,500	
		cfm	12,712	12,712	6,532	6,532	7,415	6,532	7,415	7,415	
	Control, Driving mechanism	Inverter-control, Direct-driven by motor		Inverter-control, Direct-driven by motor		Inverter-control, Direct-driven by motor		Inverter-control, Direct-driven by motor		Inverter-control, Direct-driven by motor	
	*3 Motor output	0.92 x 2		0.92 x 2		0.92 x 1	0.92 x 1	0.92 x 1	0.92 x 1	0.92 x 1	0.92 x 1
External static press.	0 Pa (0 mmH <sub>2</sub> O)		0 Pa (0 mmH <sub>2</sub> O)		0 Pa (0 mmH <sub>2</sub> O)	0 Pa (0 mmH <sub>2</sub> O)	0 Pa (0 mmH <sub>2</sub> O)	0 Pa (0 mmH <sub>2</sub> O)	0 Pa (0 mmH <sub>2</sub> O)	0 Pa (0 mmH <sub>2</sub> O)	
Compressor	Type	Inverter scroll hermetic compressor		Inverter scroll hermetic compressor		Inverter scroll hermetic compressor		Inverter scroll hermetic compressor		Inverter scroll hermetic compressor	
	Starting method	Inverter		Inverter		Inverter	Inverter	Inverter	Inverter	Inverter	Inverter
	Motor output	13.3		13.3		8.1	8.1	12.4	8.1	10.4	12.4
	Case heater	-		-		-	-	-	-	-	-
External finish	Pre-coated galvanized steel sheets (+powder coating for -BS type) <MUNSELL 3Y 7.8/1.1 or similar>		Pre-coated galvanized steel sheets (+powder coating for -BS type) <MUNSELL 3Y 7.8/1.1 or similar>		Pre-coated galvanized steel sheets (+powder coating for -BS type) <MUNSELL 3Y 7.8/1.1 or similar>		Pre-coated galvanized steel sheets (+powder coating for -BS type) <MUNSELL 3Y 7.8/1.1 or similar>		Pre-coated galvanized steel sheets (+powder coating for -BS type) <MUNSELL 3Y 7.8/1.1 or similar>		
External dimension H x W x D	mm	1,650 x 1,750 x 740	1,650 x 1,750 x 740	1,650 x 920 x 740	1,650 x 920 x 740	1,650 x 1,220 x 740	1,650 x 920 x 740	1,650 x 1,220 x 740	1,650 x 1,220 x 740	1,650 x 1,220 x 740	
	in.	65 x 68-15/16 x 29-3/16	65 x 68-15/16 x 29-3/16	65 x 36-1/4 x 29-3/16	65 x 36-1/4 x 29-3/16	65 x 48-1/16 x 29-3/16	65 x 36-1/4 x 29-3/16	65 x 48-1/16 x 29-3/16	65 x 48-1/16 x 29-3/16	65 x 48-1/16 x 29-3/16	
Protection devices	High pressure protection	High pressure sensor, High pressure switch at 4.15 MPa (601 psi)		High pressure sensor, High pressure switch at 4.15 MPa (601 psi)		High pressure sensor, High pressure switch at 4.15 MPa (601 psi)		High pressure sensor, High pressure switch at 4.15 MPa (601 psi)		High pressure sensor, High pressure switch at 4.15 MPa (601 psi)	
	Inverter circuit (COMP./FAN)	Over-heat protection, Over-current protection		Over-heat protection, Over-current protection		Over-heat protection, Over-current protection		Over-heat protection, Over-current protection		Over-heat protection, Over-current protection	
Refrigerant	Type x original charge	R410A x 11.8 kg (27 lbs)	R410A x 11.8 kg (27 lbs)	R410A x 8.0 kg (18 lbs)	R410A x 8.0 kg (18 lbs)	R410A x 11.5 kg (26 lbs)	R410A x 8.0 kg (18 lbs)	R410A x 11.5 kg (26 lbs)	R410A x 11.5 kg (26 lbs)	R410A x 11.5 kg (26 lbs)	
Net weight	kg (lbs)	285 (629)	285 (629)	204 (450)	204 (450)	241 (532)	204 (450)	243 (536)	241 (532)	241 (532)	
Heat exchanger	Salt-resistant cross fin & copper tube		Salt-resistant cross fin & copper tube		Salt-resistant cross fin & copper tube		Salt-resistant cross fin & copper tube		Salt-resistant cross fin & copper tube		
Pipe between unit and distributor	Liquid pipe	mm (in.)	15.88 (5/8) Brazed	15.88 (5/8) Brazed	12.7 (1/2) Brazed	12.7 (1/2) Brazed	15.88 (5/8) Brazed	12.7 (1/2) Brazed	12.7 (1/2) Brazed	15.88 (5/8) Brazed	
	Gas pipe	mm (in.)	28.58 (1-1/8) Brazed	28.58 (1-1/8) Brazed	22.2 (7/8) Brazed	22.2 (7/8) Brazed	28.58 (1-1/8) Brazed	22.2 (7/8) Brazed	28.58 (1-1/8) Brazed	28.58 (1-1/8) Brazed	
Optional parts	Outdoor Twinning kit: CMY-Y200VBK2 Joint: CMY-Y102SS/LS-G2, CMY-Y202S/302S-G2 Header: CMY-Y104/108/1010-G		Outdoor Twinning kit: CMY-Y200VBK2 Joint: CMY-Y102SS/LS-G2, CMY-Y202S/302S-G2 Header: CMY-Y104/108/1010-G		Outdoor Twinning kit: CMY-Y300VBK3 Joint: CMY-Y102SS/LS-G2, CMY-Y202S/302S-G2 Header: CMY-Y104/108/1010-G		Outdoor Twinning kit: CMY-Y300VBK3 Joint: CMY-Y102SS/LS-G2, CMY-Y202S/302S-G2 Header: CMY-Y104/108/1010-G		Outdoor Twinning kit: CMY-Y300VBK3 Joint: CMY-Y102SS/LS-G2, CMY-Y202S/302S-G2 Header: CMY-Y104/108/1010-G		

### Notes:

\*1,\*2 Nominal conditions

	Indoor	Outdoor	Pipe length	Level difference
Cooling	27 °CD.B./19 °CW.B. (81 °FD.B./66 °FW.B.)	35 °CD.B. (95 °FD.B.)	7.5 m (24-9/16 ft.)	0 m (0 ft.)
Heating	20 °CD.B. (68 °FD.B.)	7 °CD.B./6 °CW.B. (45 °FD.B./43 °FW.B.)	7.5 m (24-9/16 ft.)	0 m (0 ft.)

\*3 External static pressure option is available (30Pa, 60Pa / 3.1mmH<sub>2</sub>O, 6.1mmH<sub>2</sub>O).

\*Nominal condition \*1,\*2 are subject to JIS B8615-2.

\*Due to continuing improvement, above specifications may be subject to change without notice.



OUTDOOR UNIT  
**YKD-series**

# PUHY-P YSKD (-BS)



## Specifications

Model		PUHY-P1150YSKD (-BS)		PUHY-P1200YSKD (-BS)	
Power source		3-phase 4-wire 380-400-415 V 50/60 Hz		3-phase 4-wire 380-400-415 V 50/60 Hz	
Cooling capacity (Nominal)	*1 kW	130.0		135.0	
	BTU/h	443,600		460,600	
	Power input kW	34.12		38.35	
	Current input A	57.5-54.7-52.7		64.7-61.5-59.2	
EER	kW/kW	3.81		3.52	
Temp. range of cooling	Indoor W.B.	15.0~24.0 °C (59~75 °F)		15.0~24.0 °C (59~75 °F)	
	Outdoor D.B.	-5.0~52.0 °C (23~126 °F)		-5.0~52.0 °C (23~126 °F)	
Heating capacity (Nominal)	*2 kW	130.0		135.0	
	BTU/h	443,600		460,600	
	Power input kW	35.51		37.70	
	Current input A	59.9-56.9-54.8		63.6-60.4-58.2	
COP	kW/kW	3.66		3.58	
Temp. range of heating	Indoor D.B.	15.0~27.0 °C (59~81 °F)		15.0~27.0 °C (59~81 °F)	
	Outdoor W.B.	-20.0~15.5 °C (-4~60 °F)		-20.0~15.5 °C (-4~60 °F)	
Indoor unit connectable	Total capacity	50~130% of outdoor unit capacity		50~130% of outdoor unit capacity	
	Model/Quantity	P15~P600/1~50		P15~P600/1~50	
Sound pressure level (measured in anechoic room)	dB <A>	67.5		68	
Refrigerant piping diameter	Liquid pipe mm (in.)	19.05 (3/4) Brazed		19.05 (3/4) Brazed	
	Gas pipe mm (in.)	41.28 (1-5/8) Brazed		41.28 (1-5/8) Brazed	

### Set Model

Model		PUHY-P350YKD (-BS)	PUHY-P400YKD (-BS)	PUHY-P400YKD (-BS)	PUHY-P400YKD (-BS)	PUHY-P400YKD (-BS)	PUHY-P400YKD (-BS)
Fan	Type x Quantity	Propeller fan x 1		Propeller fan x 1	Propeller fan x 1	Propeller fan x 1	Propeller fan x 1
	Air flow rate	m <sup>3</sup> /min	210		210	210	210
		L/s	3,500		3,500	3,500	3,500
		cfm	7,415		7,415	7,415	7,415
Control, Driving mechanism	Inverter-control, Direct-driven by motor				Inverter-control, Direct-driven by motor		
Motor output	kW	0.92 x 1		0.92 x 1	0.92 x 1	0.92 x 1	
*3 External static press.		0 Pa (0 mmH <sub>2</sub> O)		0 Pa (0 mmH <sub>2</sub> O)	0 Pa (0 mmH <sub>2</sub> O)	0 Pa (0 mmH <sub>2</sub> O)	
Compressor	Type	Inverter scroll hermetic compressor				Inverter scroll hermetic compressor	
	Starting method	Inverter		Inverter	Inverter	Inverter	Inverter
	Motor output	kW	10.4		10.8	10.8	10.8
	Case heater	kW	-		-	-	-
External finish	Pre-coated galvanized steel sheets (+powder coating for -BS type) <MUNSELL 3Y 7.8/1.1 or similar>				Pre-coated galvanized steel sheets (+powder coating for -BS type) <MUNSELL 3Y 7.8/1.1 or similar>		
External dimension H x W x D	mm	1,650 x 1,220 x 740	1,650 x 1,220 x 740	1,650 x 1,220 x 740	1,650 x 1,220 x 740	1,650 x 1,220 x 740	1,650 x 1,220 x 740
	in.	65 x 48-1/16 x 29-3/16	65 x 48-1/16 x 29-3/16	65 x 48-1/16 x 29-3/16	65 x 48-1/16 x 29-3/16	65 x 48-1/16 x 29-3/16	65 x 48-1/16 x 29-3/16
Protection devices	High pressure protection	High pressure sensor, High pressure switch at 4.15 MPa (601 psi)				High pressure sensor, High pressure switch at 4.15 MPa (601 psi)	
	Inverter circuit (COMP./FAN)	Over-heat protection, Over-current protection				Over-heat protection, Over-current protection	
Refrigerant	Type x original charge	R410A x 11.5 kg (26 lbs)	R410A x 11.5 kg (26 lbs)	R410A x 11.5 kg (26 lbs)	R410A x 11.5 kg (26 lbs)	R410A x 11.5 kg (26 lbs)	
Net weight	kg (lbs)	243 (536)	241 (532)	241 (532)	241 (532)	241 (532)	
Heat exchanger	Salt-resistant cross fin & copper tube						
	Pipe between unit and distributor	Liquid pipe mm (in.)	12.7 (1/2) Brazed	15.88 (5/8) Brazed	15.88 (5/8) Brazed	15.88 (5/8) Brazed	15.88 (5/8) Brazed
	Gas pipe mm (in.)	28.58 (1-1/8) Brazed	28.58 (1-1/8) Brazed	28.58 (1-1/8) Brazed	28.58 (1-1/8) Brazed	28.58 (1-1/8) Brazed	
Optional parts	Outdoor Twinning kit: CMY-Y300VBK3 Joint: CMY-Y102SS/LS-G2, CMY-Y202S/302S-G2 Header: CMY-Y104/108/1010-G				Outdoor Twinning kit: CMY-Y300VBK3 Joint: CMY-Y102SS/LS-G2, CMY-Y202S/302S-G2 Header: CMY-Y104/108/1010-G		

### Notes:

\*1,\*2 Nominal conditions

	Indoor	Outdoor	Pipe length	Level difference
Cooling	27 °CD.B./19 °CW.B. (81 °FD.B./66 °FW.B.)	35 °CD.B. (95 °FD.B.)	7.5 m (24-9/16 ft.)	0 m (0 ft.)
Heating	20 °CD.B. (68 °FD.B.)	7 °CD.B./6 °CW.B. (45 °FD.B./43 °FW.B.)	7.5 m (24-9/16 ft.)	0 m (0 ft.)

\*3 External static pressure option is available (30Pa, 60Pa / 3.1mmH<sub>2</sub>O, 6.1mmH<sub>2</sub>O).

\*Nominal condition \*1,\*2 are subject to JIS B8615-2.

\*Due to continuing improvement, above specifications may be subject to change without notice.

# OUTDOOR UNIT

## YKD-series

### PUHY-P YSKD (-BS)



## Specifications

Model		PUHY-P1250YSKD (-BS)		PUHY-P1300YSKD (-BS)	
Power source		3-phase 4-wire 380-400-415 V 50/60 Hz		3-phase 4-wire 380-400-415 V 50/60 Hz	
Cooling capacity (Nominal)	*1	kW	138.0	141.0	
		BTU/h	470,900	481,100	
	Power input	kW	40.00	41.83	
	Current input	A	67.5-64.1-61.8	70.6-67.0-64.6	
	EER	kW/kW	3.45	3.37	
Temp. range of cooling	Indoor	W.B.	15.0~24.0 °C (59~75 °F)	15.0~24.0 °C (59~75 °F)	
	Outdoor	D.B.	-5.0~52.0 °C (23~126 °F)	-5.0~52.0 °C (23~126 °F)	
Heating capacity (Nominal)	*2	kW	138.0	141.0	
		BTU/h	470,900	481,100	
	Power input	kW	40.35	42.98	
	Current input	A	68.1-64.7-62.3	72.5-68.9-66.4	
	COP	kW/kW	3.42	3.28	
Temp. range of heating	Indoor	D.B.	15.0~27.0 °C (59~81 °F)	15.0~27.0 °C (59~81 °F)	
	Outdoor	W.B.	-20.0~15.5 °C (-4~60 °F)	-20.0~15.5 °C (-4~60 °F)	
Indoor unit connectable	Total capacity	50~130% of outdoor unit capacity		50~130% of outdoor unit capacity	
	Model/Quantity	P15~P600/2~50		P15~P600/2~50	
Sound pressure level (measured in anechoic room)		dB <A>	68	68	
Refrigerant piping diameter	Liquid pipe	mm (in.)	19.05 (3/4) Brazed	19.05 (3/4) Brazed	
	Gas pipe	mm (in.)	41.28 (1-5/8) Brazed	41.28 (1-5/8) Brazed	

### Set Model

Model		PUHY-P400YKD (-BS)	PUHY-P400YKD (-BS)	PUHY-P450YKD (-BS)	PUHY-P400YKD (-BS)	PUHY-P450YKD (-BS)	PUHY-P450YKD (-BS)	
Fan	Type x Quantity	Propeller fan x 1		Propeller fan x 1	Propeller fan x 1		Propeller fan x 1	
	Air flow rate	m <sup>3</sup> /min	210	210	210	210	210	
		L/s	3,500	3,500	3,500	3,500	3,500	
		cfm	7,415	7,415	7,415	7,415	7,415	
	Control, Driving mechanism	Inverter-control, Direct-driven by motor				Inverter-control, Direct-driven by motor		
Motor output	kW	0.92 x 1	0.92 x 1	0.92 x 1	0.92 x 1	0.92 x 1	0.92 x 1	
*3 External static press.		0 Pa (0 mmH <sub>2</sub> O)	0 Pa (0 mmH <sub>2</sub> O)	0 Pa (0 mmH <sub>2</sub> O)	0 Pa (0 mmH <sub>2</sub> O)	0 Pa (0 mmH <sub>2</sub> O)	0 Pa (0 mmH <sub>2</sub> O)	
Compressor	Type	Inverter scroll hermetic compressor			Inverter scroll hermetic compressor			
	Starting method	Inverter	Inverter	Inverter	Inverter	Inverter	Inverter	
	Motor output	kW	10.8	10.8	12.4	10.8	12.4	12.4
	Case heater	kW	-	-	-	-	-	-
External finish		Pre-coated galvanized steel sheets (+powder coating for -BS type) <MUNSELL 3Y 7.8/1.1 or similar>			Pre-coated galvanized steel sheets (+powder coating for -BS type) <MUNSELL 3Y 7.8/1.1 or similar>			
External dimension H x W x D	mm	1,650 x 1,220 x 740	1,650 x 1,220 x 740	1,650 x 1,220 x 740	1,650 x 1,220 x 740	1,650 x 1,220 x 740	1,650 x 1,220 x 740	
	in.	65 x 48-1/16 x 29-3/16	65 x 48-1/16 x 29-3/16	65 x 48-1/16 x 29-3/16	65 x 48-1/16 x 29-3/16	65 x 48-1/16 x 29-3/16	65 x 48-1/16 x 29-3/16	
Protection devices	High pressure protection	High pressure sensor, High pressure switch at 4.15 MPa (601 psi)			High pressure sensor, High pressure switch at 4.15 MPa (601 psi)			
	Inverter circuit (COMP./FAN)	Over-heat protection, Over-current protection			Over-heat protection, Over-current protection			
Refrigerant	Type x original charge	R410A x 11.5 kg (26 lbs)	R410A x 11.5 kg (26 lbs)	R410A x 11.5 kg (26 lbs)	R410A x 11.5 kg (26 lbs)	R410A x 11.5 kg (26 lbs)	R410A x 11.5 kg (26 lbs)	
Net weight	kg (lbs)	241 (532)	241 (532)	241 (532)	241 (532)	241 (532)	241 (532)	
Heat exchanger		Salt-resistant cross fin & copper tube			Salt-resistant cross fin & copper tube			
Pipe between unit and distributor	Liquid pipe	mm (in.)	15.88 (5/8) Brazed	15.88 (5/8) Brazed	15.88 (5/8) Brazed	15.88 (5/8) Brazed	15.88 (5/8) Brazed	
	Gas pipe	mm (in.)	28.58 (1-1/8) Brazed	28.58 (1-1/8) Brazed	28.58 (1-1/8) Brazed	28.58 (1-1/8) Brazed	28.58 (1-1/8) Brazed	
Optional parts		Outdoor Twinning kit: CMY-Y300VBK3 Joint: CMY-Y102SS/LS-G2, CMY-Y202S/302S-G2 Header: CMY-Y104/108/1010-G			Outdoor Twinning kit: CMY-Y300VBK3 Joint: CMY-Y102SS/LS-G2, CMY-Y202S/302S-G2 Header: CMY-Y104/108/1010-G			

### Notes:

\*1,\*2 Nominal conditions

	Indoor	Outdoor	Pipe length	Level difference
Cooling	27 °CD.B./19 °CW.B. (81 °FD.B./66 °FW.B.)	35 °CD.B. (95 °FD.B.)	7.5 m (24-9/16 ft.)	0 m (0 ft.)
Heating	20 °CD.B. (68 °FD.B.)	7 °CD.B./6 °CW.B. (45 °FD.B./43 °FW.B.)	7.5 m (24-9/16 ft.)	0 m (0 ft.)

\*3 External static pressure option is available (30Pa, 60Pa / 3.1mmH<sub>2</sub>O, 6.1mmH<sub>2</sub>O).

\*Nominal condition \*1,\*2 are subject to JIS B8615-2.

\*Due to continuing improvement, above specifications may be subject to change without notice.

OUTDOOR UNIT  
**YKD-series**

# PUHY-P YSKD (-BS)



## Specifications

Model		PUHY-P1350YSKD (-BS)		PUHY-P1400YSKD (-BS)	
Power source		3-phase 4-wire 380-400-415 V 50/60 Hz		3-phase 4-wire 380-400-415 V 50/60 Hz	
Cooling capacity (Nominal)	*1 kW	144.0		151.0	
	BTU/h	491,300		515,200	
	Power input kW	43.63		45.89	
	Current input A	73.6-69.9-67.4		77.4-73.5-70.9	
	EER kW/kW	3.30		3.29	
Temp. range of cooling	Indoor W.B.	15.0~24.0 °C (59~75 °F)		15.0~24.0 °C (59~75 °F)	
	Outdoor D.B.	-5.0~52.0 °C (23~126 °F)		-5.0~52.0 °C (23~126 °F)	
Heating capacity (Nominal)	*2 kW	144.0		151.0	
	BTU/h	491,300		515,200	
	Power input kW	46.15		49.50	
	Current input A	77.9-74.0-71.3		83.5-79.3-76.5	
	COP kW/kW	3.12		3.05	
Temp. range of heating	Indoor D.B.	15.0~27.0 °C (59~81 °F)		15.0~27.0 °C (59~81 °F)	
	Outdoor W.B.	-20.0~15.5 °C (-4~60 °F)		-20.0~15.5 °C (-4~60 °F)	
Indoor unit connectable	Total capacity	50~130% of outdoor unit capacity		50~130% of outdoor unit capacity	
	Model/Quantity	P15~P600/2~50		P15~P600/2~50	
Sound pressure level (measured in anechoic room)	dB <A>	68		68.5	
Refrigerant piping diameter	Liquid pipe mm (in.)	19.05 (3/4) Brazed		19.05 (3/4) Brazed	
	Gas pipe mm (in.)	41.28 (1-5/8) Brazed		41.28 (1-5/8) Brazed	

### Set Model

Model		PUHY-P450YKD (-BS)		PUHY-P450YKD (-BS)		PUHY-P450YKD (-BS)		PUHY-P450YKD (-BS)		PUHY-P450YKD (-BS)		PUHY-P500YKD (-BS)		
Fan	Type x Quantity	Propeller fan x 1		Propeller fan x 1		Propeller fan x 1		Propeller fan x 1		Propeller fan x 1		Propeller fan x 2		
	Air flow rate	m <sup>3</sup> /min	210		210		210		210		210		360	
		L/s	3,500		3,500		3,500		3,500		3,500		6,000	
		cfm	7,415		7,415		7,415		7,415		7,415		12,712	
	Control, Driving mechanism	Inverter-control, Direct-driven by motor						Inverter-control, Direct-driven by motor						
*3	Motor output kW	0.92 x 1		0.92 x 1		0.92 x 1		0.92 x 1		0.92 x 1		0.92 x 2		
	External static press.	0 Pa (0 mmH <sub>2</sub> O)		0 Pa (0 mmH <sub>2</sub> O)		0 Pa (0 mmH <sub>2</sub> O)		0 Pa (0 mmH <sub>2</sub> O)		0 Pa (0 mmH <sub>2</sub> O)		0 Pa (0 mmH <sub>2</sub> O)		
	Type	Inverter scroll hermetic compressor						Inverter scroll hermetic compressor						
	Starting method	Inverter		Inverter		Inverter		Inverter		Inverter		Inverter		
Compressor	Motor output kW	12.4		12.4		12.4		12.4		12.4		13.3		
	Case heater kW	-		-		-		-		-		-		
External finish		Pre-coated galvanized steel sheets (+powder coating for -BS type) <MUNSELL 3Y 7.8/1.1 or similar>						Pre-coated galvanized steel sheets (+powder coating for -BS type) <MUNSELL 3Y 7.8/1.1 or similar>						
External dimension H x W x D	mm	1,650 x 1,220 x 740		1,650 x 1,220 x 740		1,650 x 1,220 x 740		1,650 x 1,220 x 740		1,650 x 1,220 x 740		1,650 x 1,750 x 740		
	in.	65 x 48-1/16 x 29-3/16		65 x 48-1/16 x 29-3/16		65 x 48-1/16 x 29-3/16		65 x 48-1/16 x 29-3/16		65 x 48-1/16 x 29-3/16		65 x 68-15/16 x 29-3/16		
Protection devices	High pressure protection	High pressure sensor, High pressure switch at 4.15 MPa (601 psi)						High pressure sensor, High pressure switch at 4.15 MPa (601 psi)						
	Inverter circuit (COMP./FAN)	Over-heat protection, Over-current protection						Over-heat protection, Over-current protection						
Refrigerant	Type x original charge	R410A x 11.5 kg (26 lbs)		R410A x 11.5 kg (26 lbs)		R410A x 11.5 kg (26 lbs)		R410A x 11.5 kg (26 lbs)		R410A x 11.5 kg (26 lbs)		R410A x 11.8 kg (27 lbs)		
Net weight	kg (lbs)	241 (532)		241 (532)		241 (532)		241 (532)		241 (532)		285 (629)		
Heat exchanger		Salt-resistant cross fin & copper tube						Salt-resistant cross fin & copper tube						
Pipe between unit and distributor	Liquid pipe mm (in.)	15.88 (5/8) Brazed		15.88 (5/8) Brazed		15.88 (5/8) Brazed		15.88 (5/8) Brazed		15.88 (5/8) Brazed		15.88 (5/8) Brazed		
	Gas pipe mm (in.)	28.58 (1-1/8) Brazed		28.58 (1-1/8) Brazed		28.58 (1-1/8) Brazed		28.58 (1-1/8) Brazed		28.58 (1-1/8) Brazed		28.58 (1-1/8) Brazed		
Optional parts		Outdoor Twinning kit: CMY-Y300VBK3 Joint: CMY-Y102SS/LS-G2, CMY-Y202S/302S-G2 Header: CMY-Y104/108/1010-G						Outdoor Twinning kit: CMY-Y300VBK3 Joint: CMY-Y102SS/LS-G2, CMY-Y202S/302S-G2 Header: CMY-Y104/108/1010-G						

### Notes:

\*1,\*2 Nominal conditions

	Indoor	Outdoor	Pipe length	Level difference
Cooling	27 °CD.B./19 °CW.B. (81 °FD.B./66 °FW.B.)	35 °CD.B. (95 °FD.B.)	7.5 m (24-9/16 ft.)	0 m (0 ft.)
Heating	20 °CD.B. (68 °FD.B.)	7 °CD.B./6 °CW.B. (45 °FD.B./43 °FW.B.)	7.5 m (24-9/16 ft.)	0 m (0 ft.)

\*3 External static pressure option is available (30Pa, 60Pa / 3.1mmH<sub>2</sub>O, 6.1mmH<sub>2</sub>O).

\*Nominal condition \*1,\*2 are subject to JIS B8615-2.

\*Due to continuing improvement, above specifications may be subject to change without notice.

# OUTDOOR UNIT

## YKD-series

### PUHY-P YSKD (-BS)



## Specifications

Model		PUHY-P1450YSKD (-BS)		PUHY-P1500YSKD (-BS)	
Power source		3-phase 4-wire 380-400-415 V 50/60 Hz		3-phase 4-wire 380-400-415 V 50/60 Hz	
Cooling capacity (Nominal)	*1	kW	158.0	kW	165.0
		BTU/h	539,100	BTU/h	563,000
	Power input	kW	48.17	kW	50.45
	Current input	A	81.3-77.2-74.4	A	85.1-80.9-77.9
	EER	kW/kW	3.28	kW/kW	3.27
Temp. range of cooling	Indoor	W.B.	15.0~24.0 °C (59~75 °F)	W.B.	15.0~24.0 °C (59~75 °F)
	Outdoor	D.B.	-5.0~52.0 °C (23~126 °F)	D.B.	-5.0~52.0 °C (23~126 °F)
Heating capacity (Nominal)	*2	kW	158.0	kW	165.0
		BTU/h	539,100	BTU/h	563,000
	Power input	kW	52.49	kW	56.12
	Current input	A	88.6-84.1-81.1	A	94.7-90.0-86.7
	COP	kW/kW	3.01	kW/kW	2.94
Temp. range of heating	Indoor	D.B.	15.0~27.0 °C (59~81 °F)	D.B.	15.0~27.0 °C (59~81 °F)
	Outdoor	W.B.	-20.0~15.5 °C (-4~60 °F)	W.B.	-20.0~15.5 °C (-4~60 °F)
Indoor unit connectable	Total capacity	50~130% of outdoor unit capacity		50~130% of outdoor unit capacity	
	Model/Quantity	P15~P600/2~50		P15~P600/2~50	
Sound pressure level (measured in anechoic room)		dB <A>	69.5	dB <A>	70
Refrigerant piping diameter	Liquid pipe	mm (in.)	19.05 (3/4) Brazed	mm (in.)	19.05 (3/4) Brazed
	Gas pipe	mm (in.)	41.28 (1-5/8) Brazed	mm (in.)	41.28 (1-5/8) Brazed

### Set Model

Model		PUHY-P450YKD (-BS)	PUHY-P500YKD (-BS)	PUHY-P500YKD (-BS)	PUHY-P500YKD (-BS)	PUHY-P500YKD (-BS)	PUHY-P500YKD (-BS)	
Fan	Type x Quantity	Propeller fan x 1	Propeller fan x 2	Propeller fan x 2	Propeller fan x 2	Propeller fan x 2	Propeller fan x 2	
	Air flow rate	m <sup>3</sup> /min	210	360	360	360	360	360
		L/s	3,500	6,000	6,000	6,000	6,000	6,000
		cfm	7,415	12,712	12,712	12,712	12,712	12,712
	Control, Driving mechanism	Inverter-control, Direct-driven by motor			Inverter-control, Direct-driven by motor			
	Motor output	kW	0.92 x 1	0.92 x 2	0.92 x 2	0.92 x 2	0.92 x 2	
	*3 External static press.	0 Pa (0 mmH <sub>2</sub> O)	0 Pa (0 mmH <sub>2</sub> O)	0 Pa (0 mmH <sub>2</sub> O)	0 Pa (0 mmH <sub>2</sub> O)	0 Pa (0 mmH <sub>2</sub> O)	0 Pa (0 mmH <sub>2</sub> O)	
Compressor	Type	Inverter scroll hermetic compressor			Inverter scroll hermetic compressor			
	Starting method	Inverter	Inverter	Inverter	Inverter	Inverter	Inverter	
	Motor output	kW	12.4	13.3	13.3	13.3	13.3	
	Case heater	kW	-	-	-	-	-	
External finish		Pre-coated galvanized steel sheets (+powder coating for -BS type) <MUNSELL 3Y 7.8/1.1 or similar>			Pre-coated galvanized steel sheets (+powder coating for -BS type) <MUNSELL 3Y 7.8/1.1 or similar>			
External dimension H x W x D	mm	1,650 x 1,220 x 740	1,650 x 1,750 x 740	1,650 x 1,750 x 740	1,650 x 1,750 x 740	1,650 x 1,750 x 740	1,650 x 1,750 x 740	
	in.	65 x 48-1/16 x 29-3/16	65 x 68-15/16 x 29-3/16	65 x 68-15/16 x 29-3/16	65 x 68-15/16 x 29-3/16	65 x 68-15/16 x 29-3/16	65 x 68-15/16 x 29-3/16	
Protection devices	High pressure protection	High pressure sensor, High pressure switch at 4.15 MPa (601 psi)			High pressure sensor, High pressure switch at 4.15 MPa (601 psi)			
	Inverter circuit (COMP./FAN)	Over-heat protection, Over-current protection			Over-heat protection, Over-current protection			
Refrigerant	Type x original charge	R410A x 11.5 kg (26 lbs)	R410A x 11.8 kg (27 lbs)	R410A x 11.8 kg (27 lbs)	R410A x 11.8 kg (27 lbs)	R410A x 11.8 kg (27 lbs)	R410A x 11.8 kg (27 lbs)	
Net weight	kg (lbs)	241 (532)	285 (629)	285 (629)	285 (629)	285 (629)	285 (629)	
Heat exchanger		Salt-resistant cross fin & copper tube			Salt-resistant cross fin & copper tube			
Pipe between unit and distributor	Liquid pipe	mm (in.)	15.88 (5/8) Brazed	15.88 (5/8) Brazed	15.88 (5/8) Brazed	15.88 (5/8) Brazed	15.88 (5/8) Brazed	
	Gas pipe	mm (in.)	28.58 (1-1/8) Brazed	28.58 (1-1/8) Brazed	28.58 (1-1/8) Brazed	28.58 (1-1/8) Brazed	28.58 (1-1/8) Brazed	
Optional parts		Outdoor Twinning kit: CMY-Y300VBK3 Joint: CMY-Y102SS/LS-G2, CMY-Y202S/302S-G2 Header: CMY-Y104/108/1010-G			Outdoor Twinning kit: CMY-Y300VBK3 Joint: CMY-Y102SS/LS-G2, CMY-Y202S/302S-G2 Header: CMY-Y104/108/1010-G			

### Notes:

\*1,\*2 Nominal conditions

	Indoor	Outdoor	Pipe length	Level difference
Cooling	27 °CD.B./19 °CW.B. (81 °FD.B./66 °FW.B.)	35 °CD.B. (95 °FD.B.)	7.5 m (24-9/16 ft.)	0 m (0 ft.)
Heating	20 °CD.B. (68 °FD.B.)	7 °CD.B./6 °CW.B. (45 °FD.B./43 °FW.B.)	7.5 m (24-9/16 ft.)	0 m (0 ft.)

\*3 External static pressure option is available (30Pa, 60Pa / 3.1mmH<sub>2</sub>O, 6.1mmH<sub>2</sub>O).

\*Nominal condition \*1,\*2 are subject to JIS B8615-2.

\*Due to continuing improvement, above specifications may be subject to change without notice.

OUTDOOR UNIT

**YKD-series - High Efficiency**

**PUHY-EP YSKD (-BS)**



**Specifications**

Model	PUHY-EP400YSKD (-BS)		PUHY-EP450YSKD (-BS)		PUHY-EP500YSKD (-BS)			
Power source	3-phase 4-wire 380-400-415 V 50/60 Hz		3-phase 4-wire 380-400-415 V 50/60 Hz		3-phase 4-wire 380-400-415 V 50/60 Hz			
Cooling capacity (Nominal)	*1	kW	44.8	50.4	56.0			
		BTU/h	152,900	172,000	191,100			
	Power input	kW	9.21	10.54	11.91			
		Current input	A	15.5-14.7-14.2	17.7-16.9-16.2	20.1-19.1-18.4		
		EER	kW/kW	4.86	4.78	4.70		
Temp. range of cooling	Indoor	W.B.	15.0~24.0 °C (59~75 °F)	15.0~24.0 °C (59~75 °F)	15.0~24.0 °C (59~75 °F)			
	Outdoor	D.B.	-5.0~52.0 °C (23~126 °F)	-5.0~52.0 °C (23~126 °F)	-5.0~52.0 °C (23~126 °F)			
Heating capacity (Nominal)	*2	kW	44.8	50.4	56.0			
		BTU/h	152,900	172,000	191,100			
	Power input	kW	10.66	12.00	13.36			
		Current input	A	17.9-17.0-16.4	20.2-19.2-18.5	22.5-21.4-20.6		
		COP	kW/kW	4.20	4.20	4.19		
Temp. range of heating	Indoor	D.B.	15.0~27.0 °C (59~81 °F)	15.0~27.0 °C (59~81 °F)	15.0~27.0 °C (59~81 °F)			
	Outdoor	W.B.	-20.0~15.5 °C (-4~60 °F)	-20.0~15.5 °C (-4~60 °F)	-20.0~15.5 °C (-4~60 °F)			
Indoor unit connectable	Total capacity	50~130% of outdoor unit capacity		50~130% of outdoor unit capacity		50~130% of outdoor unit capacity		
	Model/Quantity	P15~P400/1~34		P15~P400/1~39		P15~P500/1~43		
Sound pressure level (measured in anechoic room)	dB <A>	60		60.5		61		
Refrigerant piping diameter	Liquid pipe	mm (in.)	12.7 (1/2) Brazed		15.88 (5/8) Brazed		15.88 (5/8) Brazed	
	Gas pipe	mm (in.)	28.58 (1-1/8) Brazed		28.58 (1-1/8) Brazed		28.58 (1-1/8) Brazed	

**Set Model**

Model	PUHY-P200YKD (-BS)		PUHY-P200YKD (-BS)		PUHY-P200YKD (-BS)		PUHY-P250YKD (-BS)		PUHY-P250YKD (-BS)		PUHY-P250YKD (-BS)				
Fan	Type x Quantity	Propeller fan x 1		Propeller fan x 1		Propeller fan x 1		Propeller fan x 1		Propeller fan x 1		Propeller fan x 1			
	Air flow rate	m <sup>3</sup> /min	175		175		175		175		175		175		
			L/s	2,917		2,917		2,917		2,917		2,917		2,917	
				cfm	6,179		6,179		6,179		6,179		6,179		6,179
	Control, Driving mechanism	Inverter-control, Direct-driven by motor				Inverter-control, Direct-driven by motor				Inverter-control, Direct-driven by motor					
Compressor	Motor output	0.92 x 1		0.92 x 1		0.92 x 1		0.92 x 1		0.92 x 1		0.92 x 1			
	*3 External static press.	0 Pa (0 mmH <sub>2</sub> O)		0 Pa (0 mmH <sub>2</sub> O)		0 Pa (0 mmH <sub>2</sub> O)		0 Pa (0 mmH <sub>2</sub> O)		0 Pa (0 mmH <sub>2</sub> O)		0 Pa (0 mmH <sub>2</sub> O)			
	Type	Inverter scroll hermetic compressor				Inverter scroll hermetic compressor				Inverter scroll hermetic compressor					
	Starting method	Inverter		Inverter		Inverter		Inverter		Inverter		Inverter			
	Motor output	5.5		5.5		5.5		6.9		6.9		6.9			
External finish	Case heater	-		-		-		-		-		-			
		Pre-coated galvanized steel sheets (+powder coating for -BS type) <MUNSELL 3Y 7.8/1.1 or similar>				Pre-coated galvanized steel sheets (+powder coating for -BS type) <MUNSELL 3Y 7.8/1.1 or similar>				Pre-coated galvanized steel sheets (+powder coating for -BS type) <MUNSELL 3Y 7.8/1.1 or similar>					
External dimension H x W x D	mm	1,650 x 920 x 740		1,650 x 920 x 740		1,650 x 920 x 740		1,650 x 920 x 740		1,650 x 920 x 740		1,650 x 920 x 740			
	in.	65 x 36-1/4 x 29-3/16		65 x 36-1/4 x 29-3/16		65 x 36-1/4 x 29-3/16		65 x 36-1/4 x 29-3/16		65 x 36-1/4 x 29-3/16		65 x 36-1/4 x 29-3/16			
Protection devices	High pressure protection	High pressure sensor, High pressure switch at 4.15 MPa (601 psi)				High pressure sensor, High pressure switch at 4.15 MPa (601 psi)				High pressure sensor, High pressure switch at 4.15 MPa (601 psi)					
	Inverter circuit (COMP./FAN)	Over-heat protection, Over-current protection				Over-heat protection, Over-current protection				Over-heat protection, Over-current protection					
Refrigerant	Type x original charge	R410A x 8.0 kg (18 lbs)		R410A x 8.0 kg (18 lbs)		R410A x 8.0 kg (18 lbs)		R410A x 8.0 kg (18 lbs)		R410A x 8.0 kg (18 lbs)		R410A x 8.0 kg (18 lbs)			
Net weight	kg (lbs)	191 (422)		191 (422)		191 (422)		191 (422)		191 (422)		191 (422)			
Heat exchanger		Salt-resistant cross fin & copper tube				Salt-resistant cross fin & copper tube				Salt-resistant cross fin & copper tube					
Pipe between unit and distributor	Liquid pipe	mm (in.)	9.52 (3/8) Brazed		9.52 (3/8) Brazed		9.52 (3/8) Brazed		9.52 (3/8) Brazed		9.52 (3/8) Brazed		9.52 (3/8) Brazed		
	Gas pipe	mm (in.)	22.2 (7/8) Brazed		22.2 (7/8) Brazed		22.2 (7/8) Brazed		22.2 (7/8) Brazed		22.2 (7/8) Brazed		22.2 (7/8) Brazed		
Optional parts		Outdoor Twinning kit: CMY-Y100VBK3 Joint: CMY-Y102SS/LS-G2, CMY-Y202S-G2 Header: CMY-Y104/108/1010-G				Outdoor Twinning kit: CMY-Y100VBK3 Joint: CMY-Y102SS/LS-G2, CMY-Y202S-G2 Header: CMY-Y104/108/1010-G				Outdoor Twinning kit: CMY-Y100VBK3 Joint: CMY-Y102SS/LS-G2, CMY-Y202S-G2 Header: CMY-Y104/108/1010-G					

**Notes:**

\*1,\*2 Nominal conditions

	Indoor	Outdoor	Pipe length	Level difference
Cooling	27 °CD.B./19 °CW.B. (81 °FD.B./66 °FW.B.)	35 °CD.B. (95 °FD.B.)	7.5 m (24-9/16 ft.)	0 m (0 ft.)
Heating	20 °CD.B. (68 °FD.B.)	7 °CD.B./6 °CW.B. (45 °FD.B./43 °FW.B.)	7.5 m (24-9/16 ft.)	0 m (0 ft.)

\*3 External static pressure option is available (30Pa / 3.1mmH<sub>2</sub>O, 6.1mmH<sub>2</sub>O).

\*Nominal condition \*1,\*2 are subject to JIS B8615-2.

\*Due to continuing improvement, above specifications may be subject to change without notice.



## OUTDOOR UNIT

## YKD-series - High Efficiency

## PUHY-EP YSKD (-BS)



Advantages of CITY MULTI

Outdoor/Heat source unit

Indoor unit

Remote Controller

Lossnay

Installation information

## Specifications

Model		PUHY-EP650YSKD (-BS)		PUHY-EP700YSKD (-BS)		
Power source		3-phase 4-wire 380-400-415 V 50/60 Hz		3-phase 4-wire 380-400-415 V 50/60 Hz		
Cooling capacity (Nominal)	*1 kW	73.5		80.0		
	BTU/h	250,800		273,000		
	Power input kW	17.83		19.75		
	Current input A	30.0-28.5-27.5		33.3-31.6-30.5		
EER	kW/kW	4.12		4.05		
Temp. range of cooling	Indoor	W.B.	15.0~24.0 °C (59~75 °F)		15.0~24.0 °C (59~75 °F)	
	Outdoor	D.B.	-5.0~52.0 °C (23~126 °F)		-5.0~52.0 °C (23~126 °F)	
Heating capacity (Nominal)	*2 kW	73.5		80.0		
	BTU/h	250,800		273,000		
	Power input kW	18.70		20.25		
	Current input A	31.5-29.9-28.9		34.1-32.4-31.3		
COP	kW/kW	3.93		3.95		
Temp. range of heating	Indoor	D.B.	15.0~27.0 °C (59~81 °F)		15.0~27.0 °C (59~81 °F)	
	Outdoor	W.B.	-20.0~15.5 °C (-4~60 °F)		-20.0~15.5 °C (-4~60 °F)	
Indoor unit connectable	Total capacity	50~130% of outdoor unit capacity		50~130% of outdoor unit capacity		
	Model/Quantity	P15~P600/1~50		P15~P600/1~50		
Sound pressure level (measured in anechoic room)	dB <A>	64		64		
Refrigerant piping diameter	Liquid pipe	mm (in.)	15.88 (5/8) Brazed		19.05 (3/4) Brazed	
	Gas pipe	mm (in.)	28.58 (1-1/8) Brazed		34.93 (1-3/8) Brazed	

## Set Model

Model		PUHY-P300YKD (-BS)		PUHY-P350YKD (-BS)		PUHY-P350YKD (-BS)		PUHY-P350YKD (-BS)		
Fan	Type x Quantity	Propeller fan x 1		Propeller fan x 1		Propeller fan x 1		Propeller fan x 1		
	Air flow rate	m <sup>3</sup> /min	185		210		210		210	
		L/s	3,083		3,500		3,500		3,500	
		cfm	6,532		7,415		7,415		7,415	
	Control, Driving mechanism	Inverter-control, Direct-driven by motor				Inverter-control, Direct-driven by motor				
	Motor output	kW	0.92 x 1		0.92 x 1		0.92 x 1		0.92 x 1	
Compressor	*3 External static press.	0 Pa (0 mmH <sub>2</sub> O)		0 Pa (0 mmH <sub>2</sub> O)		0 Pa (0 mmH <sub>2</sub> O)		0 Pa (0 mmH <sub>2</sub> O)		
	Type	Inverter scroll hermetic compressor				Inverter scroll hermetic compressor				
	Starting method	Inverter		Inverter		Inverter		Inverter		
	Motor output	kW	8.1		10.4		10.4		10.4	
	Case heater	kW	-		-		-		-	
External finish	Pre-coated galvanized steel sheets (+powder coating for -BS type) <MUNSELL 3Y 7.8/1.1 or similar>				Pre-coated galvanized steel sheets (+powder coating for -BS type) <MUNSELL 3Y 7.8/1.1 or similar>					
External dimension H x W x D	mm	1,650 x 920 x 740		1,650 x 1,220 x 740		1,650 x 1,220 x 740		1,650 x 1,220 x 740		
	in.	65 x 36-1/4 x 29-3/16		65 x 48-1/16 x 29-3/16		65 x 48-1/16 x 29-3/16		65 x 48-1/16 x 29-3/16		
Protection devices	High pressure protection	High pressure sensor, High pressure switch at 4.15 MPa (601 psi)				High pressure sensor, High pressure switch at 4.15 MPa (601 psi)				
	Inverter circuit (COMP./FAN)	Over-heat protection, Over-current protection				Over-heat protection, Over-current protection				
Refrigerant	Type x original charge	R410A x 8.0 kg (18 lbs)		R410A x 11.5 kg (26 lbs)		R410A x 11.5 kg (26 lbs)		R410A x 11.5 kg (26 lbs)		
Net weight	kg (lbs)	204 (450)		243 (536)		243 (536)		243 (536)		
Heat exchanger	Salt-resistant cross fin & copper tube				Salt-resistant cross fin & copper tube					
Pipe between unit and distributor	Liquid pipe	mm (in.)	12.7 (1/2) Brazed		12.7 (1/2) Brazed		12.7 (1/2) Brazed		12.7 (1/2) Brazed	
	Gas pipe	mm (in.)	22.2 (7/8) Brazed		28.58 (1-1/8) Brazed		28.58 (1-1/8) Brazed		28.58 (1-1/8) Brazed	
Optional parts	Outdoor Twinning kit: CMY-Y100VBK3 Joint: CMY-Y102SS/LS-G2, CMY-Y202S/302S-G2 Header: CMY-Y104/108/1010-G				Outdoor Twinning kit: CMY-Y200VBK2 Joint: CMY-Y102SS/LS-G2, CMY-Y202S/302S-G2 Header: CMY-Y104/108/1010-G					

## Notes:

\*1,\*2 Nominal conditions

	Indoor	Outdoor	Pipe length	Level difference
Cooling	27 °CD.B./19 °CW.B. (81 °FD.B./66 °FW.B.)	35 °CD.B. (95 °FD.B.)	7.5 m (24-9/16 ft.)	0 m (0 ft.)
Heating	20 °CD.B. (68 °FD.B.)	7 °CD.B./6 °CW.B. (45 °FD.B./43 °FW.B.)	7.5 m (24-9/16 ft.)	0 m (0 ft.)

\*3 External static pressure option is available (30Pa, 60Pa / 3.1mmH<sub>2</sub>O, 6.1mmH<sub>2</sub>O).

\*Nominal condition \*1,\*2 are subject to JIS B8615-2.

\*Due to continuing improvement, above specifications may be subject to change without notice.

OUTDOOR UNIT

**YKD-series - High Efficiency**

**PUHY-EP YSKD (-BS)**



**Specifications**

Model	PUHY-EP750YSKD (-BS)	PUHY-EP800YSKD (-BS)	PUHY-EP850YSKD (-BS)
Power source	3-phase 4-wire 380-400-415 V 50/60 Hz	3-phase 4-wire 380-400-415 V 50/60 Hz	3-phase 4-wire 380-400-415 V 50/60 Hz
Cooling capacity (Nominal)	*1 kW	84.8	90.4
	BTU/h	289,300	308,400
	Power input kW	19.18	20.82
	Current input A	32.3-30.7-29.6	35.1-33.3-32.1
EER	kW/kW	4.42	4.34
			4.26
Temp. range of cooling	Indoor W.B.	15.0~24.0 °C (59~75 °F)	15.0~24.0 °C (59~75 °F)
	Outdoor D.B.	-5.0~52.0 °C (23~126 °F)	-5.0~52.0 °C (23~126 °F)
Heating capacity (Nominal)	*2 kW	84.8	90.4
	BTU/h	289,300	308,400
	Power input kW	20.58	21.99
	Current input A	34.7-33.0-31.8	37.1-35.2-33.9
COP	kW/kW	4.12	4.11
			39.4-37.4-36.0
Temp. range of heating	Indoor D.B.	15.0~27.0 °C (59~81 °F)	15.0~27.0 °C (59~81 °F)
	Outdoor W.B.	-20.0~15.5 °C (-4~60 °F)	-20.0~15.5 °C (-4~60 °F)
Indoor unit connectable	Total capacity	50~130% of outdoor unit capacity	50~130% of outdoor unit capacity
	Model/Quantity	P15~P600/1~50	P15~P600/1~50
Sound pressure level (measured in anechoic room)	dB <A>	64	64
Refrigerant piping diameter	Liquid pipe mm (in.)	19.05 (3/4) Brazed	19.05 (3/4) Brazed
	Gas pipe mm (in.)	34.93 (1-3/8) Brazed	34.93 (1-3/8) Brazed

**Set Model**

Model	PUHY-P200YKD (-BS)	PUHY-P200YKD (-BS)	PUHY-P350YKD (-BS)	PUHY-P200YKD (-BS)	PUHY-P250YKD (-BS)	PUHY-P350YKD (-BS)	PUHY-P250YKD (-BS)	PUHY-P250YKD (-BS)	PUHY-P350YKD (-BS)	
Fan	Type x Quantity	Propeller fan x 1	Propeller fan x 1	Propeller fan x 1	Propeller fan x 1	Propeller fan x 1	Propeller fan x 1	Propeller fan x 1	Propeller fan x 1	
	Air flow rate	m <sup>3</sup> /min	175	175	210	175	175	210	175	210
		L/s	2,917	2,917	3,500	2,917	2,917	3,500	2,917	3,500
		cfm	6,179	6,179	7,415	6,179	6,179	7,415	6,179	7,415
	Control, Driving mechanism	Inverter-control, Direct-driven by motor			Inverter-control, Direct-driven by motor			Inverter-control, Direct-driven by motor		
	Motor output kW	0.92 x 1	0.92 x 1	0.92 x 1	0.92 x 1	0.92 x 1	0.92 x 1	0.92 x 1	0.92 x 1	0.92 x 1
External static press.	0 Pa (0 mmH <sub>2</sub> O)	0 Pa (0 mmH <sub>2</sub> O)	0 Pa (0 mmH <sub>2</sub> O)	0 Pa (0 mmH <sub>2</sub> O)	0 Pa (0 mmH <sub>2</sub> O)	0 Pa (0 mmH <sub>2</sub> O)	0 Pa (0 mmH <sub>2</sub> O)	0 Pa (0 mmH <sub>2</sub> O)	0 Pa (0 mmH <sub>2</sub> O)	
	0 Pa (0 mmH <sub>2</sub> O)	0 Pa (0 mmH <sub>2</sub> O)	0 Pa (0 mmH <sub>2</sub> O)	0 Pa (0 mmH <sub>2</sub> O)	0 Pa (0 mmH <sub>2</sub> O)	0 Pa (0 mmH <sub>2</sub> O)	0 Pa (0 mmH <sub>2</sub> O)	0 Pa (0 mmH <sub>2</sub> O)	0 Pa (0 mmH <sub>2</sub> O)	
	0 Pa (0 mmH <sub>2</sub> O)	0 Pa (0 mmH <sub>2</sub> O)	0 Pa (0 mmH <sub>2</sub> O)	0 Pa (0 mmH <sub>2</sub> O)	0 Pa (0 mmH <sub>2</sub> O)	0 Pa (0 mmH <sub>2</sub> O)	0 Pa (0 mmH <sub>2</sub> O)	0 Pa (0 mmH <sub>2</sub> O)	0 Pa (0 mmH <sub>2</sub> O)	
Compressor	Type	Inverter scroll hermetic compressor			Inverter scroll hermetic compressor			Inverter scroll hermetic compressor		
	Starting method	Inverter	Inverter	Inverter	Inverter	Inverter	Inverter	Inverter	Inverter	
	Motor output kW	5.5	5.5	10.4	5.5	6.9	10.4	6.9	6.9	10.4
	Case heater kW	-	-	-	-	-	-	-	-	-
External finish	Pre-coated galvanized steel sheets (+powder coating for -BS type) <MUNSELL 3Y 7.8/1.1 or similar>			Pre-coated galvanized steel sheets (+powder coating for -BS type) <MUNSELL 3Y 7.8/1.1 or similar>			Pre-coated galvanized steel sheets (+powder coating for -BS type) <MUNSELL 3Y 7.8/1.1 or similar>			
	Pre-coated galvanized steel sheets (+powder coating for -BS type) <MUNSELL 3Y 7.8/1.1 or similar>			Pre-coated galvanized steel sheets (+powder coating for -BS type) <MUNSELL 3Y 7.8/1.1 or similar>			Pre-coated galvanized steel sheets (+powder coating for -BS type) <MUNSELL 3Y 7.8/1.1 or similar>			
External dimension H x W x D	mm	1,650 x 920 x 740	1,650 x 920 x 740	1,650 x 1,220 x 740	1,650 x 920 x 740	1,650 x 920 x 740	1,650 x 1,220 x 740	1,650 x 920 x 740	1,650 x 1,220 x 740	
	in.	65 x 36-1/4 x 29-3/16	65 x 36-1/4 x 29-3/16	65 x 48-1/16 x 29-3/16	65 x 36-1/4 x 29-3/16	65 x 36-1/4 x 29-3/16	65 x 48-1/16 x 29-3/16	65 x 36-1/4 x 29-3/16	65 x 48-1/16 x 29-3/16	
Protection devices	High pressure protection	High pressure sensor, High pressure switch at 4.15 MPa (601 psi)			High pressure sensor, High pressure switch at 4.15 MPa (601 psi)			High pressure sensor, High pressure switch at 4.15 MPa (601 psi)		
	Inverter circuit (COMP./FAN)	Over-heat protection, Over-current protection			Over-heat protection, Over-current protection			Over-heat protection, Over-current protection		
	Refrigerant	Type x original charge	R410A x 8.0 kg (18 lbs)	R410A x 8.0 kg (18 lbs)	R410A x 11.5 kg (26 lbs)	R410A x 8.0 kg (18 lbs)	R410A x 8.0 kg (18 lbs)	R410A x 11.5 kg (26 lbs)	R410A x 8.0 kg (18 lbs)	R410A x 11.5 kg (26 lbs)
Net weight	kg (lbs)	191 (422)	191 (422)	243 (536)	191 (422)	191 (422)	243 (536)	191 (422)	191 (422)	243 (536)
Heat exchanger	Salt-resistant cross fin & copper tube			Salt-resistant cross fin & copper tube			Salt-resistant cross fin & copper tube			
Pipe between unit and distributor	Liquid pipe	9.52 (3/8) Brazed	9.52 (3/8) Brazed	12.7 (1/2) Brazed	9.52 (3/8) Brazed	9.52 (3/8) Brazed	12.7 (1/2) Brazed	9.52 (3/8) Brazed	9.52 (3/8) Brazed	12.7 (1/2) Brazed
	Gas pipe	22.2 (7/8) Brazed	22.2 (7/8) Brazed	28.58 (1-1/8) Brazed	22.2 (7/8) Brazed	22.2 (7/8) Brazed	28.58 (1-1/8) Brazed	22.2 (7/8) Brazed	22.2 (7/8) Brazed	28.58 (1-1/8) Brazed
Optional parts	Outdoor Twinning kit: CMY-Y300VBK3 Joint: CMY-Y102SS/LS-G2, CMY-Y202S/302S-G2 Header: CMY-Y104/108/1010-G			Outdoor Twinning kit: CMY-Y300VBK3 Joint: CMY-Y102SS/LS-G2, CMY-Y202S/302S-G2 Header: CMY-Y104/108/1010-G			Outdoor Twinning kit: CMY-Y300VBK3 Joint: CMY-Y102SS/LS-G2, CMY-Y202S/302S-G2 Header: CMY-Y104/108/1010-G			

**Notes:**

\*1,\*2 Nominal conditions

	Indoor	Outdoor	Pipe length	Level difference
Cooling	27 °CD.B./19 °CW.B. (81 °FD.B./66 °FW.B.)	35 °CD.B. (95 °FD.B.)	7.5 m (24-9/16 ft.)	0 m (0 ft.)
Heating	20 °CD.B. (68 °FD.B.)	7 °CD.B./6 °CW.B. (45 °FD.B./43 °FW.B.)	7.5 m (24-9/16 ft.)	0 m (0 ft.)

\*3 External static pressure option is available (30Pa, 60Pa / 3.1mmH<sub>2</sub>O, 6.1mmH<sub>2</sub>O).

\*Nominal condition \*1,\*2 are subject to JIS B8615-2.

\*Due to continuing improvement, above specifications may be subject to change without notice.

OUTDOOR UNIT

**YKD-series - High Efficiency**

**PUHY-EP YSKD (-BS)**



**Specifications**

Model	PUHY-EP900YSKD (-BS)		PUHY-EP950YSKD (-BS)		PUHY-EP1000YSKD (-BS)		
Power source	3-phase 4-wire 380-400-415 V 50/60 Hz		3-phase 4-wire 380-400-415 V 50/60 Hz		3-phase 4-wire 380-400-415 V 50/60 Hz		
Cooling capacity (Nominal)	*1 kW	101.5	107.0		113.5		
	BTU/h	346,300	365,100		387,300		
	Power input kW	24.16	26.75		28.80		
	Current input A	40.7-38.7-37.3	45.1-42.9-41.3		48.6-46.1-44.5		
EER	kW/kW	4.20	4.00		3.94		
Temp. range of cooling	Indoor	W.B. 15.0~24.0 °C (59~75 °F)	15.0~24.0 °C (59~75 °F)		15.0~24.0 °C (59~75 °F)		
	Outdoor	D.B. -5.0~52.0 °C (23~126 °F)	-5.0~52.0 °C (23~126 °F)		-5.0~52.0 °C (23~126 °F)		
Heating capacity (Nominal)	*2 kW	101.5	107.0		113.5		
	BTU/h	346,300	365,100		387,300		
	Power input kW	25.24	27.22		28.80		
	Current input A	42.6-40.4-39.0	45.9-43.6-42.0		48.6-46.1-44.5		
COP	kW/kW	4.02	3.93		3.94		
Temp. range of heating	Indoor	D.B. 15.0~27.0 °C (59~81 °F)	15.0~27.0 °C (59~81 °F)		15.0~27.0 °C (59~81 °F)		
	Outdoor	W.B. -20.0~15.5 °C (-4~60 °F)	-20.0~15.5 °C (-4~60 °F)		-20.0~15.5 °C (-4~60 °F)		
Indoor unit connectable	Total capacity	50~130% of outdoor unit capacity		50~130% of outdoor unit capacity		50~130% of outdoor unit capacity	
	Model/Quantity	P15~P600/1~50		P15~P600/1~50		P15~P600/1~50	
Sound pressure level (measured in anechoic room)	dB <A>	65		66		66	
Refrigerant piping diameter	Liquid pipe	19.05 (3/4) Brazed		19.05 (3/4) Brazed		19.05 (3/4) Brazed	
	Gas pipe	41.28 (1-5/8) Brazed		41.28 (1-5/8) Brazed		41.28 (1-5/8) Brazed	

**Set Model**

Model	PUHY-P250YKD (-BS)	PUHY-P300YKD (-BS)	PUHY-P350YKD (-BS)	PUHY-P300YKD (-BS)	PUHY-P300YKD (-BS)	PUHY-P350YKD (-BS)	PUHY-P300YKD (-BS)	PUHY-P350YKD (-BS)	PUHY-P350YKD (-BS)		
Fan	Type x Quantity		Propeller fan x 1	Propeller fan x 1	Propeller fan x 1	Propeller fan x 1	Propeller fan x 1	Propeller fan x 1	Propeller fan x 1		
	Air flow rate	m <sup>3</sup> /min	175	185	210	185	185	210	185	210	
		L/s	2,917	3,083	3,500	3,083	3,083	3,500	3,083	3,500	
		cfm	6,179	6,532	7,415	6,532	6,532	7,415	6,532	7,415	
	Control, Driving mechanism		Inverter-control, Direct-driven by motor			Inverter-control, Direct-driven by motor			Inverter-control, Direct-driven by motor		
	Motor output	kW	0.92 x 1	0.92 x 1	0.92 x 1	0.92 x 1	0.92 x 1	0.92 x 1	0.92 x 1	0.92 x 1	
*3 External static press.	0 Pa (0 mmH <sub>2</sub> O)		0 Pa (0 mmH <sub>2</sub> O)	0 Pa (0 mmH <sub>2</sub> O)	0 Pa (0 mmH <sub>2</sub> O)	0 Pa (0 mmH <sub>2</sub> O)	0 Pa (0 mmH <sub>2</sub> O)	0 Pa (0 mmH <sub>2</sub> O)	0 Pa (0 mmH <sub>2</sub> O)		
	Compressor		Inverter scroll hermetic compressor			Inverter scroll hermetic compressor			Inverter scroll hermetic compressor		
	Starting method		Inverter	Inverter	Inverter	Inverter	Inverter	Inverter	Inverter		
Motor output	kW	6.9	8.1	10.4	8.1	8.1	10.4	8.1	10.4		
Case heater	kW	-	-	-	-	-	-	-	-		
External finish		Pre-coated galvanized steel sheets (+powder coating for -BS type) <MUNSELL 3Y 7.8/1.1 or similar>			Pre-coated galvanized steel sheets (+powder coating for -BS type) <MUNSELL 3Y 7.8/1.1 or similar>			Pre-coated galvanized steel sheets (+powder coating for -BS type) <MUNSELL 3Y 7.8/1.1 or similar>			
External dimension H x W x D	mm	1,650 x 920 x 740	1,650 x 920 x 740	1,650 x 1,220 x 740	1,650 x 920 x 740	1,650 x 920 x 740	1,650 x 920 x 740	1,650 x 1,220 x 740	1,650 x 1,220 x 740		
	in.	65 x 36-1/4 x 29-3/16	65 x 36-1/4 x 29-3/16	65 x 48-1/16 x 29-3/16	65 x 36-1/4 x 29-3/16	65 x 36-1/4 x 29-3/16	65 x 48-1/16 x 29-3/16	65 x 36-1/4 x 29-3/16	65 x 48-1/16 x 29-3/16		
Protection devices	High pressure protection	High pressure sensor, High pressure switch at 4.15 MPa (601 psi)			High pressure sensor, High pressure switch at 4.15 MPa (601 psi)			High pressure sensor, High pressure switch at 4.15 MPa (601 psi)			
	Inverter circuit (COMP./FAN)	Over-heat protection, Over-current protection			Over-heat protection, Over-current protection			Over-heat protection, Over-current protection			
Refrigerant	Type x original charge	R410A x 8.0 kg (18 lbs)	R410A x 8.0 kg (18 lbs)	R410A x 11.5 kg (26 lbs)	R410A x 8.0 kg (18 lbs)	R410A x 8.0 kg (18 lbs)	R410A x 11.5 kg (26 lbs)	R410A x 8.0 kg (18 lbs)	R410A x 11.5 kg (26 lbs)		
Net weight	kg (lbs)	191 (422)	204 (450)	243 (536)	204 (450)	204 (450)	243 (536)	204 (450)	243 (536)		
Heat exchanger		Salt-resistant cross fin & copper tube			Salt-resistant cross fin & copper tube			Salt-resistant cross fin & copper tube			
Pipe between unit and distributor	Liquid pipe	9.52 (3/8) Brazed	12.7 (1/2) Brazed	12.7 (1/2) Brazed	12.7 (1/2) Brazed	12.7 (1/2) Brazed	12.7 (1/2) Brazed	12.7 (1/2) Brazed	12.7 (1/2) Brazed		
	Gas pipe	22.2 (7/8) Brazed	22.2 (7/8) Brazed	28.58 (1-1/8) Brazed	22.2 (7/8) Brazed	22.2 (7/8) Brazed	28.58 (1-1/8) Brazed	22.2 (7/8) Brazed	28.58 (1-1/8) Brazed		
Optional parts		Outdoor Twinning kit: CMY-Y300VBK3 Joint: CMY-Y102SS/LS-G2, CMY-Y202S/302S-G2 Header: CMY-Y104/108/1010-G			Outdoor Twinning kit: CMY-Y300VBK3 Joint: CMY-Y102SS/LS-G2, CMY-Y202S/302S-G2 Header: CMY-Y104/108/1010-G			Outdoor Twinning kit: CMY-Y300VBK3 Joint: CMY-Y102SS/LS-G2, CMY-Y202S/302S-G2 Header: CMY-Y104/108/1010-G			

**Notes:**

\*1,\*2 Nominal conditions

	Indoor	Outdoor	Pipe length	Level difference
Cooling	27 °CD.B./19 °CW.B. (81 °FD.B./66 °FW.B.)	35 °CD.B. (95 °FD.B.)	7.5 m (24-9/16 ft.)	0 m (0 ft.)
Heating	20 °CD.B. (68 °FD.B.)	7 °CD.B./6 °CW.B. (45 °FD.B./43 °FW.B.)	7.5 m (24-9/16 ft.)	0 m (0 ft.)

\*3 External static pressure option is available (30Pa, 60Pa / 3.1mmH<sub>2</sub>O, 6.1mmH<sub>2</sub>O).

\*Nominal condition \*1,\*2 are subject to JIS B8615-2.

\*Due to continuing improvement, above specifications may be subject to change without notice.

Advantages of CITY MULTI

Outdoor/Heat source unit

Indoor unit

Remote Controller

Lossnay

Installation information

OUTDOOR UNIT

**YKD-series - High Efficiency**

**PUHY-EP YSKD (-BS)**



**Specifications**

Model		PUHY-EP1050YSKD (-BS)		PUHY-EP1100YSKD (-BS)	
Power source		3-phase 4-wire 380-400-415 V 50/60 Hz		3-phase 4-wire 380-400-415 V 50/60 Hz	
Cooling capacity (Nominal)	*1 kW	120.0		125.0	
	BTU/h	409,400		426,500	
	Power input kW	29.62		32.55	
	Current input A	50.0-47.5-45.7		54.9-52.2-50.3	
EER	kW/kW	4.05		3.84	
Temp. range of cooling	Indoor W.B.	15.0~24.0 °C (59~75 °F)		15.0~24.0 °C (59~75 °F)	
	Outdoor D.B.	-5.0~52.0 °C (23~126 °F)		-5.0~52.0 °C (23~126 °F)	
Heating capacity (Nominal)	*2 kW	120.0		125.0	
	BTU/h	409,400		426,500	
	Power input kW	31.25		33.24	
	Current input A	52.7-50.1-48.3		56.1-53.3-51.3	
COP	kW/kW	3.84		3.76	
Temp. range of heating	Indoor D.B.	15.0~27.0 °C (59~81 °F)		15.0~27.0 °C (59~81 °F)	
	Outdoor W.B.	-20.0~15.5 °C (-4~60 °F)		-20.0~15.5 °C (-4~60 °F)	
Indoor unit connectable	Total capacity	50~130% of outdoor unit capacity		50~130% of outdoor unit capacity	
	Model/Quantity	P15~P600/1~50		P15~P600/1~50	
Sound pressure level (measured in anechoic room)	dB <A>	66		67	
Refrigerant piping diameter	Liquid pipe mm (in.)	19.05 (3/4) Brazed		19.05 (3/4) Brazed	
	Gas pipe mm (in.)	41.28 (1-5/8) Brazed		41.28 (1-5/8) Brazed	

**Set Model**

Model		PUHY-P350YKD (-BS)	PUHY-P350YKD (-BS)	PUHY-P350YKD (-BS)	PUHY-P350YKD (-BS)	PUHY-P350YKD (-BS)	PUHY-P400YKD (-BS)	
Fan	Type x Quantity	Propeller fan x 1		Propeller fan x 1		Propeller fan x 1		
	Air flow rate	m <sup>3</sup> /min	210		210		210	
		L/s	3,500		3,500		3,500	
		cfm	7,415		7,415		7,415	
Control, Driving mechanism	Inverter-control, Direct-driven by motor				Inverter-control, Direct-driven by motor			
*3	Motor output kW	0.92 x 1		0.92 x 1		0.92 x 1		
	External static press.	0 Pa (0 mmH <sub>2</sub> O)		0 Pa (0 mmH <sub>2</sub> O)		0 Pa (0 mmH <sub>2</sub> O)		
	Type	Inverter scroll hermetic compressor				Inverter scroll hermetic compressor		
	Starting method	Inverter		Inverter		Inverter		Inverter
Compressor	Motor output kW	10.4		10.4		10.4		
	Case heater kW	-		-		-		
External finish	Pre-coated galvanized steel sheets (+powder coating for -BS type) <MUNSELL 3Y 7.8/1.1 or similar>				Pre-coated galvanized steel sheets (+powder coating for -BS type) <MUNSELL 3Y 7.8/1.1 or similar>			
External dimension H x W x D	mm	1,650 x 1,220 x 740		1,650 x 1,220 x 740		1,650 x 1,220 x 740		
	in.	65 x 48-1/16 x 29-3/16		65 x 48-1/16 x 29-3/16		65 x 48-1/16 x 29-3/16		
Protection devices	High pressure protection	High pressure sensor, High pressure switch at 4.15 MPa (601 psi)				High pressure sensor, High pressure switch at 4.15 MPa (601 psi)		
	Inverter circuit (COMP./FAN)	Over-heat protection, Over-current protection				Over-heat protection, Over-current protection		
Refrigerant	Type x original charge	R410A x 11.5 kg (26 lbs)	R410A x 11.5 kg (26 lbs)	R410A x 11.5 kg (26 lbs)	R410A x 11.5 kg (26 lbs)	R410A x 11.5 kg (26 lbs)	R410A x 11.5 kg (26 lbs)	
Net weight	kg (lbs)	243 (536)		243 (536)		243 (536)		
Heat exchanger	Salt-resistant cross fin & copper tube							
	Pipe between unit and distributor	Liquid pipe mm (in.)	12.7 (1/2) Brazed		12.7 (1/2) Brazed		15.88 (5/8) Brazed	
Optional parts	Gas pipe mm (in.)	28.58 (1-1/8) Brazed		28.58 (1-1/8) Brazed		28.58 (1-1/8) Brazed		
	Outdoor Twinning kit: CMY-Y300VBK3 Joint: CMY-Y102SS/LS-G2, CMY-Y202S/302S-G2 Header: CMY-Y104/108/1010-G				Outdoor Twinning kit: CMY-Y300VBK3 Joint: CMY-Y102SS/LS-G2, CMY-Y202S/302S-G2 Header: CMY-Y104/108/1010-G			

**Notes:**

\*1,\*2 Nominal conditions

	Indoor	Outdoor	Pipe length	Level difference
Cooling	27 °CD.B./19 °CW.B. (81 °FD.B./66 °FW.B.)	35 °CD.B. (95 °FD.B.)	7.5 m (24-9/16 ft.)	0 m (0 ft.)
Heating	20 °CD.B. (68 °FD.B.)	7 °CD.B./6 °CW.B. (45 °FD.B./43 °FW.B.)	7.5 m (24-9/16 ft.)	0 m (0 ft.)

\*3 External static pressure option is available (30Pa, 60Pa / 3.1mmH<sub>2</sub>O, 6.1mmH<sub>2</sub>O).

\*Nominal condition \*1,\*2 are subject to JIS B8615-2.

\*Due to continuing improvement, above specifications may be subject to change without notice.

## Optional Parts for Outdoor Units

### For PUCY-Series

Description	Model	Remarks
Twinning kit	CMY-Y100VBK3	For PUCY-P550-P650YSKD / EP400-EP650YSKD
	CMY-Y200VBK2	For PUCY-P700-P1000YSKD / EP700YSKD
	CMY-Y300VBK3	For PUCY-P1050-P1500YSKD / EP750-EP1100YSKD
Branch pipe (Joint)	CMY-Y102SS-G2	200 or below (Total capacity of indoor unit)
	CMY-Y102LS-G2	201-400 (Total capacity of indoor unit)
	CMY-Y202S-G2	401-650 (Total capacity of indoor unit)
		The 1st branch of P450-P650
	CMY-Y302S-G2	651 or above (Total capacity of indoor unit)
The 1st branch of P700-P1250		
Branch pipe (Header)	CMY-Y104-G	For 4 branches
	CMY-Y108-G	For 8 branches
	CMY-Y1010-G	For 10 branches

Note: Indoor unit capacities: the capacity of an indoor unit is the same as the number used for its type identification.

### For PUHY-Series

Description	Model	Remarks
Twinning kit	CMY-Y100VBK3	For PUHY-P550-P650YSKD / EP400-EP650YSKD
	CMY-Y200VBK2	For PUHY-P700-P1000YSKD / EP700YSKD
	CMY-Y300VBK3	For PUHY-P1050-P1500YSKD / EP750-EP1100YSKD
Branch pipe (Joint)	CMY-Y102SS-G2	200 or below (Total capacity of indoor unit)
	CMY-Y102LS-G2	201-400 (Total capacity of indoor unit)
	CMY-Y202S-G2	401-650 (Total capacity of indoor unit)
		The 1st branch of P450-P650
	CMY-Y302S-G2	651 or above (Total capacity of indoor unit)
The 1st branch of P700-P1250		
Branch pipe (Header)	CMY-Y104-G	For 4 branches
	CMY-Y108-G	For 8 branches
	CMY-Y1010-G	For 10 branches

Note: Indoor unit capacities: the capacity of an indoor unit is the same as the number used for its type identification.



# WY-series

## PQHY

Another offer using a water circuit for VRF. The water cooled systems offer greater flexibility in installation.



Installation image (WY-Series)

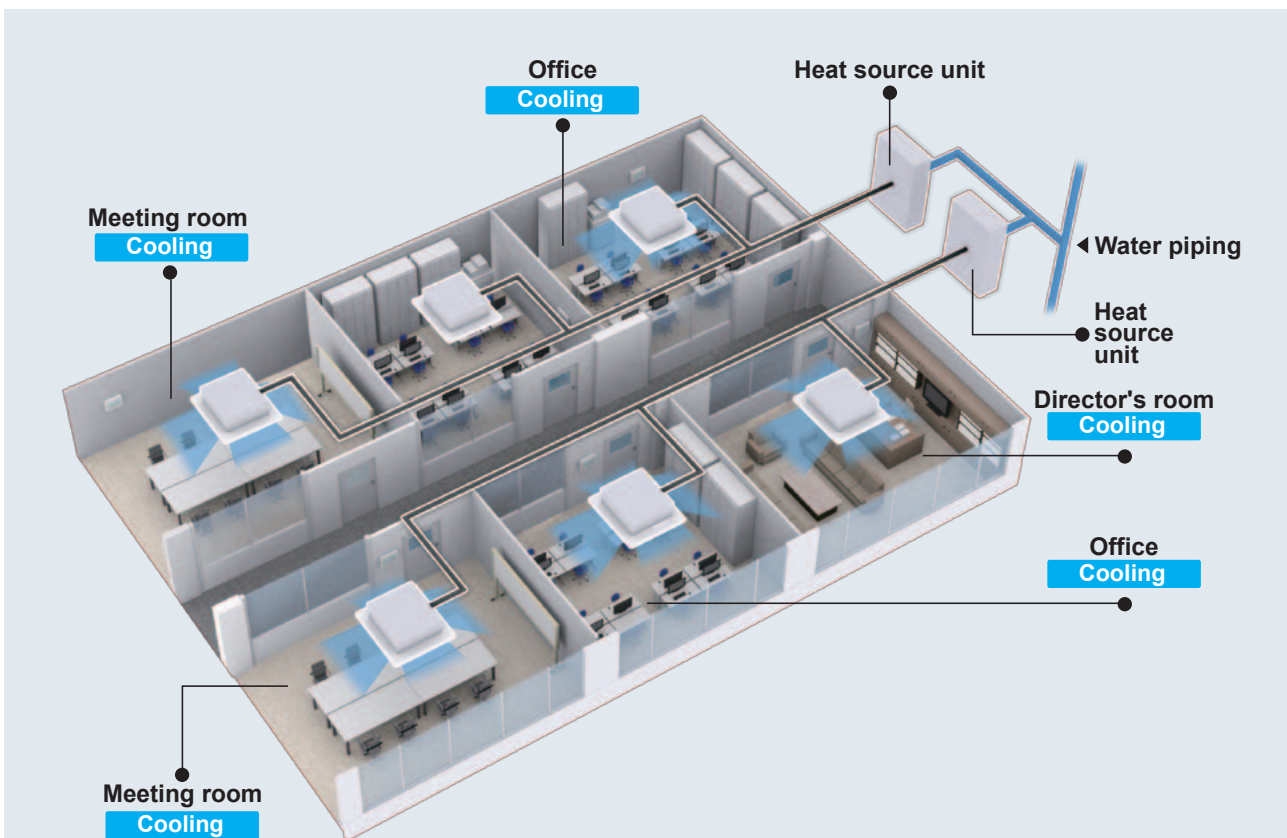

The CITY MULTI WY-Series has all the benefits of the Y-Series using water source condensing units. Condensing units can be situated indoors allowing greater design flexibility.

Depending on capacity, up to 15 to 50 indoor units can be connected to a single condensing unit with individualized and/or centralized control. The two-pipe system allows all CITY MULTI solutions to switch between cooling and heating while maintaining a constant indoor temperature.

Compact outdoor units can be easily installed in the machine rooms on each floor. This helps overcome the restriction on differences in height of refrigerant piping. Individual air conditioning can be easily provided in high-rise buildings using this system.

Individual air conditioning in high-rise buildings and underground shopping districts are made possible by using water piping, which offers greater usability over longer distances.



- Water cooled systems can be used even in buildings that are taller than 50 m by running a main water pipe through each floor\*.  
\* Depends on filed supplied water circuit.
- Any heat source system that can supply heat source water between 10°C to 45°C can be used.

Heat source units can be installed in the machine room of each individual floor.

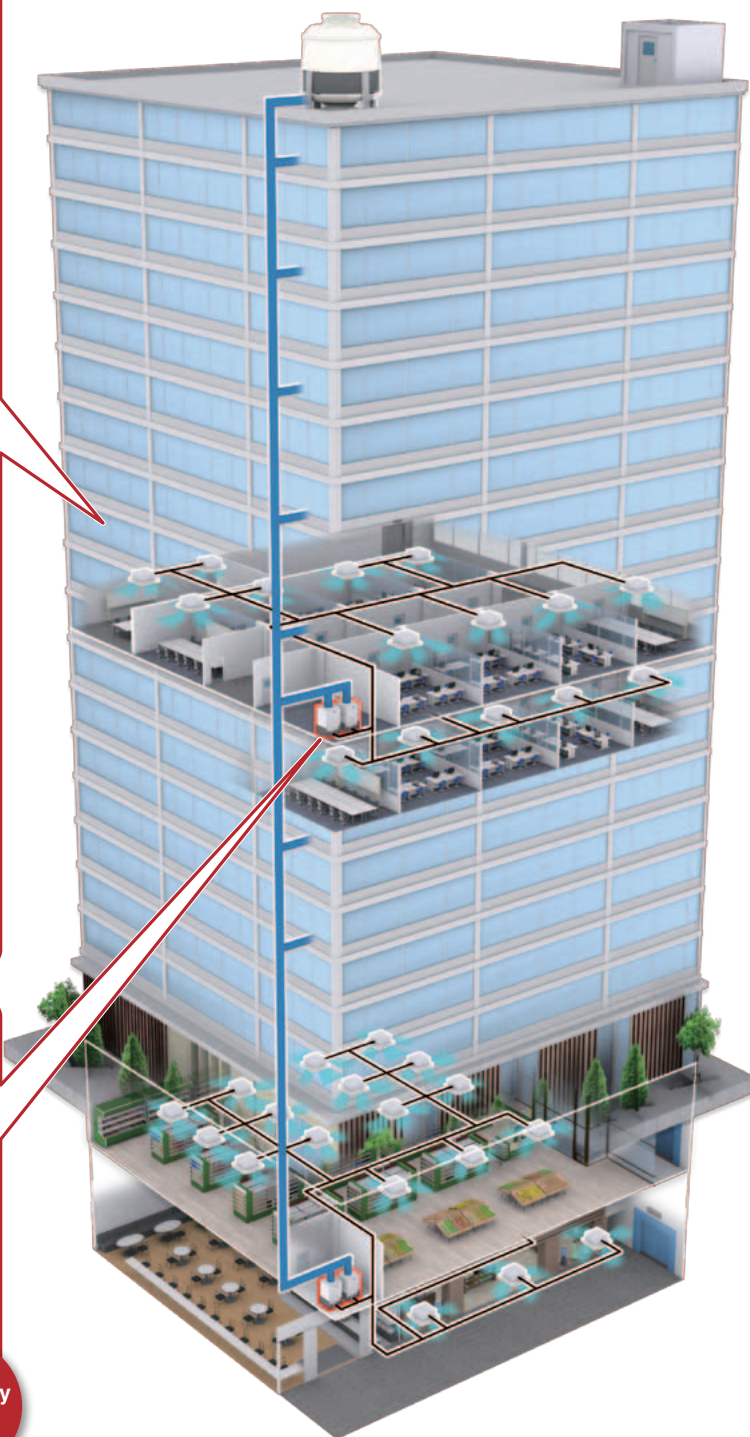
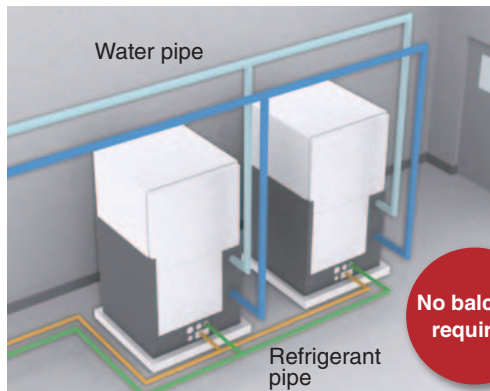

# YLM-Series

Wide capacity range available, single module capable of up to P600 and combination module up to P900.



Single- or combination-module units are available to meet various installation conditions and capacity requirements.

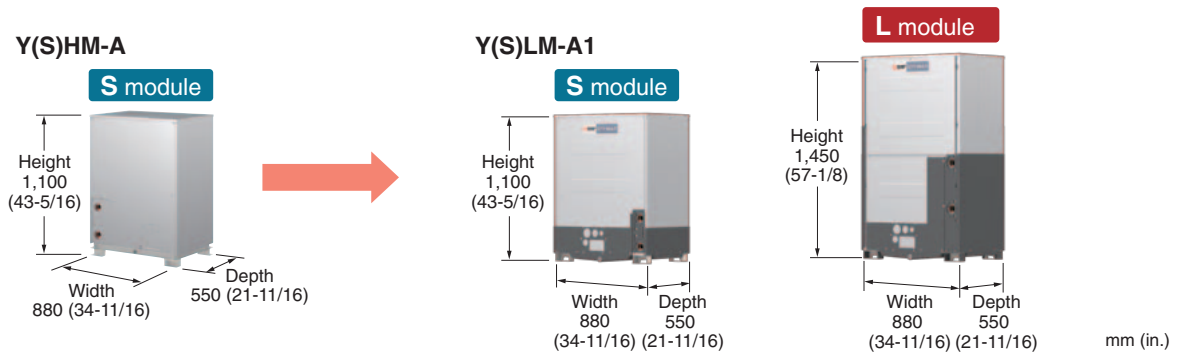

## WY-Series

Single-module units available up to P600

		P200	P250	P300	P350	P400	P450	P500	P550	P600	P650	P700	P750	P800	P850	P900
PQHY-P Y(S)LM-A1	Single	S	S	S	L	L	L	L	L	L						
PQHY-P Y(S)HM-A	Single	S	S	S												
PQHY-P Y(S)LM-A1	Combination					S+S	S+S	S+S	S+S	S+S		L+L	L+L	L+L	L+L	L+L
PQHY-P Y(S)HM-A	Combination					S+S	S+S	S+S	S+S	S+S	S+S+S	S+S+S	S+S+S	S+S+S	S+S+S	S+S+S

## Benefit of single module wide capacity range

### Less piping work

Capable of covering up to P600 (24 HP) with a single module.

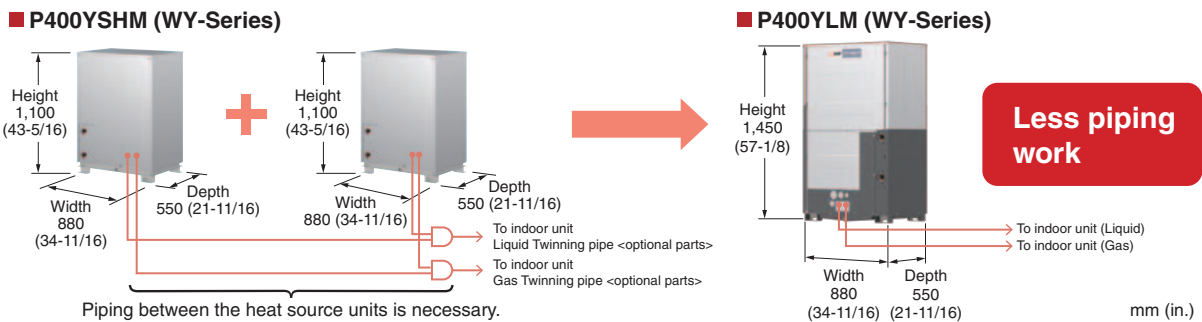

### Less footprint

Less footprint by the enhancement of the lineup of single-module units.

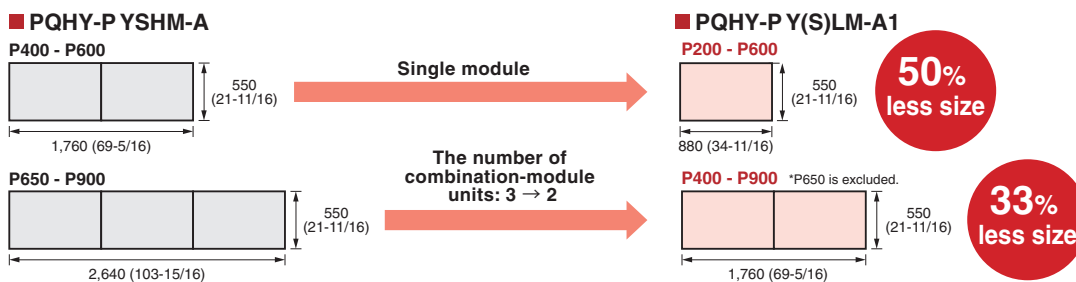



## Water flow rate control

System energy consumption can be improved by changing the water flow volume during partial load and thereby reducing water pump consumption.

- Control of water flow rate  
Control output voltage (0-10V) to adjust valve opening  
[0V: Full open, 10V: close]
- Voltage at 0 volt: Even when power is down, water will continue to circulate.

\* When using "water flow rate control", the pump needs to be controlled by inverter.  
\* Pump interlock is required.

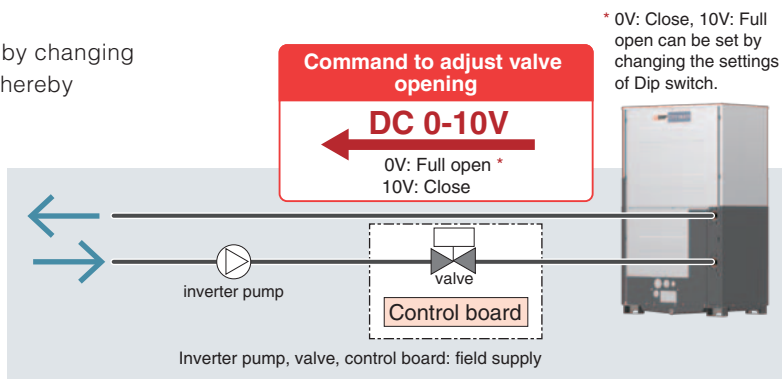

## Power saving setting for the pump

On the A1 type models, the water control valve is closed during standby and Thermo-OFF to reduce the circulating water flow rate achieving the reduction in power consumption of the pump.

### Standard

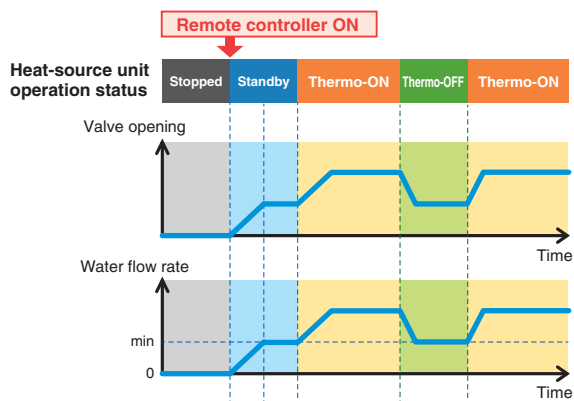

\*The pump shall be controlled by inverter.

### Power-save settings for the pump

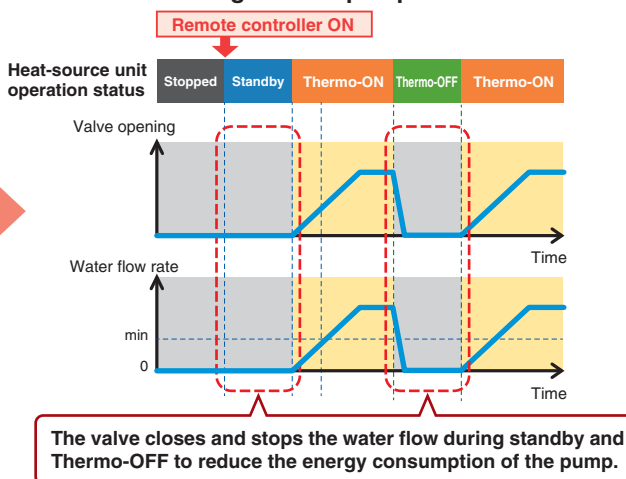

## Self-cooling device

Because the heat source unit includes a self-cooling device, there is no need to secure space for installing a separate cooling device such as a fan.



## System Pipe Lengths

[P200-P900 (WY-Series)]

Refrigerant Piping Lengths	Maximum meters [Feet]
Total length	300-500 [984-1640]
Maximum allowable length	165 (190 equivalent) [541 (623)]
Farthest indoor from first branch	40 [131]*2

Vertical differentials between units	Maximum meters [Feet]
Indoor/heat source (heat source higher)	50 [164]
Indoor/heat source (heat source lower)	40 [131]
Indoor/indoor	15 [49]

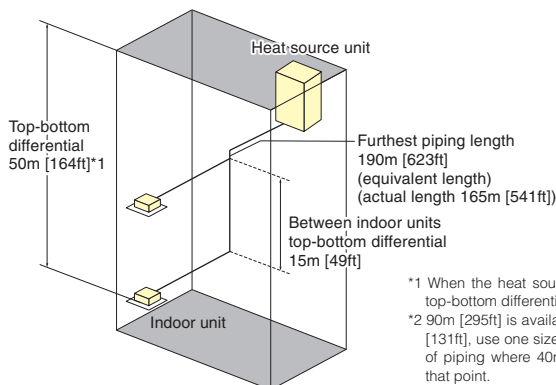

\*1 When the heat source unit is installed below the indoor unit, top-bottom differential is 40m [131ft].  
\*2 90m [295ft] is available. When the piping length exceeds 40m [131ft], use one size larger liquid pipe starting with the section of piping where 40m [131ft] is exceeded and all piping after that point.

HEAT SOURCE UNIT

**WY-series (Heat pump)**

**PQHY-P YLM-A1**



**Specifications**

Model		PQHY-P200YLM-A1	PQHY-P250YLM-A1	PQHY-P300YLM-A1	
Power source		3-phase 4-wire 380-400-415 V 50/60 Hz			
Cooling capacity (Nominal)	*1 kW	22.4	28.0	33.5	
	*1 BTU / h	76,400	95,500	114,300	
	Power input kW	3.71	4.90	6.04	
	Current input A	6.2-5.9-5.7	8.2-7.8-7.5	10.1-9.6-9.3	
Temp. range of cooling	EER kW / kW	6.03	5.71	5.54	
	Indoor W.B.	15.0~24.0°C (59~75°F)	15.0~24.0°C (59~75°F)	15.0~24.0°C (59~75°F)	
Heating capacity (Nominal)	Inlet water °C	10.0~45.0°C (50~113°F)	10.0~45.0°C (50~113°F)	10.0~45.0°C (50~113°F)	
	*2 kW	25.0	31.5	37.5	
Temp. range of heating	*2 BTU / h	85,300	107,500	128,000	
	Power input kW	3.97	5.08	6.25	
	Current input A	6.7-6.3-6.1	8.5-8.1-7.8	10.5-10.0-9.6	
	COP kW / kW	6.29	6.20	6.00	
Indoor unit connectable	Indoor D.B.	15.0~27.0°C (59~81°F)	15.0~27.0°C (59~81°F)	15.0~27.0°C (59~81°F)	
	Inlet water °C	10.0~45.0°C (50~113°F)	10.0~45.0°C (50~113°F)	10.0~45.0°C (50~113°F)	
Sound pressure level (measured in anechoic room)	Total capacity Model / Quantity	50~130% of heat source unit capacity P15~P250/1~17	50~130% of heat source unit capacity P15~P250/1~21	50~130% of heat source unit capacity P15~P300/1~26	
	Model / Quantity	P15~P250/1~17	P15~P250/1~21	P15~P300/1~26	
Refrigerant piping diameter	dB <A>	46	48	54	
	Liquid pipe mm (in.)	9.52 (3/8) Brazed	9.52 (3/8) Brazed (12.7 (1/2) Brazed, farthest length >= 90 m)	9.52 (3/8) Brazed (12.7 (1/2) Brazed, farthest length >= 40 m)	
Circulating water	Gas pipe mm (in.)	19.05 (3/4) Brazed	22.2 (7/8) Brazed	22.2 (7/8) Brazed	
	Water flow rate m <sup>3</sup> / h	L/min	5.76	5.76	5.76
		cfm	96	96	96
		Pressure drop kPa	3.4	3.4	3.4
	Operating volume range m <sup>3</sup> / h	24	24	24	
Compressor	Type	Inverter scroll hermetic compressor	Inverter scroll hermetic compressor	Inverter scroll hermetic compressor	
	Starting method	Inverter	Inverter	Inverter	
	Motor output kW	4.8	6.2	7.7	
	Case heater kW	-	-	-	
External finish	Galvanized steel sheets				
External dimension HxWxD	mm	1,100 x 880 x 550	1,100 x 880 x 550	1,100 x 880 x 550	
	in.	43-5/16 x 34-11/16 x 21-11/16	43-5/16 x 34-11/16 x 21-11/16	43-5/16 x 34-11/16 x 21-11/16	
Protection devices	High pressure protection	High pressure sensor, High pressure switch at 4.15 MPa (601 psi)	High pressure sensor, High pressure switch at 4.15 MPa (601 psi)	High pressure sensor, High pressure switch at 4.15 MPa (601 psi)	
	Inverter circuit (COMP.)	Over-heat protection, Over-current protection	Over-heat protection, Over-current protection	Over-heat protection, Over-current protection	
	Compressor	Over-heat protection	Over-heat protection	Over-heat protection	
Refrigerant	Type x original charge	R410A x 5.0 kg (12 lbs)	R410A x 5.0 kg (12 lbs)	R410A x 5.0 kg (12 lbs)	
Net weight	kg (lbs)	170 (375)	170 (375)	170 (375)	
Heat exchanger	plate type				
	Water volume in plate L	5.0	5.0	5.0	
	Water pressure Max. MPa	2.0	2.0	2.0	
Optional parts	Joint: CMY-Y102SS/LS-G2 Header: CMY-Y104, 108, 1010-G				

**Notes:**

\*1,\*2 Nominal conditions

	Indoor	Inlet water temperature	Pipe length	Level difference
Cooling	27°C D.B./19°C W.B. (81°F D.B./66°F W.B.)	30°C (86°F)	7.5m (24-9/16ft.)	0m (0ft.)
Heating	20°C D.B. (68°F D.B.)	20°C (68°F)		

- \*The ambient temperature of the heat source unit needs to be kept below 40°C D.B.
- \*The ambient relative humidity of the heat source unit needs to be kept below 80%.
- \*The heat source unit should not be installed at outdoor.
- \*Be sure to mount a strainer (more than 50 meshes) at the water inlet piping of the unit.
- \*Be sure to provide interlocking for the unit operation and water circuit.
- \*Nominal condition \*1,\*2 are subject to JIS B8615-2.
- \*Due to continuing improvement, above specification may be subject to change without notice.



HEAT SOURCE UNIT

WY-series (Heat pump)

PQHY-P YLM-A1



Advantages of CITY MULTI

Outdoor/Heat source unit

Indoor unit

Remote Controller

Lossnay

Installation information

Specifications

Model	PQHY-P350YLM-A1		PQHY-P400YLM-A1		PQHY-P450YLM-A1	
Power source	3-phase 4-wire 380-400-415 V 50/60 Hz		3-phase 4-wire 380-400-415 V 50/60 Hz		3-phase 4-wire 380-400-415 V 50/60 Hz	
Cooling capacity (Nominal)	*1 kW	40.0	45.0	50.0	50.0	50.0
	*1 BTU / h	136,500	153,500	170,600	170,600	170,600
	Power input kW	7.14	8.03	9.29	9.29	9.29
	Current input A	12.0-11.4-11.0	13.5-12.8-12.4	15.6-14.8-14.3	15.6-14.8-14.3	15.6-14.8-14.3
Temp. range of cooling	EER kW / kW	5.60	5.60	5.38	5.38	5.38
	Indoor W.B.	15.0~24.0°C (59~75°F)	15.0~24.0°C (59~75°F)	15.0~24.0°C (59~75°F)	15.0~24.0°C (59~75°F)	15.0~24.0°C (59~75°F)
	Inlet water °C	10.0~45.0°C (50~113°F)	10.0~45.0°C (50~113°F)	10.0~45.0°C (50~113°F)	10.0~45.0°C (50~113°F)	10.0~45.0°C (50~113°F)
Heating capacity (Nominal)	*2 kW	45.0	50.0	56.0	56.0	56.0
	*2 BTU / h	153,500	170,600	191,100	191,100	191,100
	Power input kW	7.53	8.37	9.79	9.79	9.79
	Current input A	12.7-12.0-11.6	14.1-13.4-12.9	16.5-15.7-15.1	16.5-15.7-15.1	16.5-15.7-15.1
Temp. range of heating	COP kW / kW	5.97	5.97	5.72	5.72	5.72
	Indoor D.B.	15.0~27.0°C (59~81°F)	15.0~27.0°C (59~81°F)	15.0~27.0°C (59~81°F)	15.0~27.0°C (59~81°F)	15.0~27.0°C (59~81°F)
	Inlet water °C	10.0~45.0°C (50~113°F)	10.0~45.0°C (50~113°F)	10.0~45.0°C (50~113°F)	10.0~45.0°C (50~113°F)	10.0~45.0°C (50~113°F)
Indoor unit connectable	Total capacity	50~130% of heat source unit capacity	50~130% of heat source unit capacity	50~130% of heat source unit capacity	50~130% of heat source unit capacity	50~130% of heat source unit capacity
	Model / Quantity	P15~P300/1~30	P15~P400/1~34	P15~P400/1~34	P15~P400/1~34	P15~P400/1~39
Sound pressure level (measured in anechoic room)	Model					
	Quantity	52	52	54	54	54
Refrigerant piping diameter	Liquid pipe mm (in.)	12.7 (1/2) Brazed	15.88 (5/8) Brazed	15.88 (5/8) Brazed	15.88 (5/8) Brazed	15.88 (5/8) Brazed
	Gas pipe mm (in.)	28.58 (1-1/8) Brazed	28.58 (1-1/8) Brazed	28.58 (1-1/8) Brazed	28.58 (1-1/8) Brazed	28.58 (1-1/8) Brazed
Circulating water	Water flow rate	m <sup>3</sup> / h	7.20	7.20	7.20	7.20
		L/min	120	120	120	120
		cfm	4.2	4.2	4.2	4.2
	Pressure drop	kPa	44	44	44	44
		Operating volume range m <sup>3</sup> / h	4.5 ~ 11.6	4.5 ~ 11.6	4.5 ~ 11.6	4.5 ~ 11.6
Compressor	Type	Inverter scroll hermetic compressor	Inverter scroll hermetic compressor	Inverter scroll hermetic compressor	Inverter scroll hermetic compressor	Inverter scroll hermetic compressor
	Starting method	Inverter	Inverter	Inverter	Inverter	
	Motor output kW	9.5	10.7	11.6	11.6	
	Case heater kW	-	-	-	-	
External finish	Galvanized steel sheets		Galvanized steel sheets		Galvanized steel sheets	
External dimension HxWxD	mm	1,450 x 880 x 550	1,450 x 880 x 550	1,450 x 880 x 550	1,450 x 880 x 550	1,450 x 880 x 550
	in.	57-1/8 x 34-11/16 x 21-11/16	57-1/8 x 34-11/16 x 21-11/16	57-1/8 x 34-11/16 x 21-11/16	57-1/8 x 34-11/16 x 21-11/16	57-1/8 x 34-11/16 x 21-11/16
Protection devices	High pressure protection	High pressure sensor, High pressure switch at 4.15 MPa (601 psi)	High pressure sensor, High pressure switch at 4.15 MPa (601 psi)	High pressure sensor, High pressure switch at 4.15 MPa (601 psi)	High pressure sensor, High pressure switch at 4.15 MPa (601 psi)	High pressure sensor, High pressure switch at 4.15 MPa (601 psi)
	Inverter circuit (COMP.)	Over-heat protection, Over-current protection	Over-heat protection, Over-current protection	Over-heat protection, Over-current protection	Over-heat protection, Over-current protection	Over-heat protection, Over-current protection
	Compressor	Over-heat protection	Over-heat protection	Over-heat protection	Over-heat protection	
Refrigerant	Type x original charge	R410A x 6.0 kg (14 lbs)	R410A x 6.0 kg (14 lbs)	R410A x 6.0 kg (14 lbs)	R410A x 6.0 kg (14 lbs)	
Net weight	kg (lbs)	214 (472)	214 (472)	214 (472)	214 (472)	
Heat exchanger	plate type		plate type		plate type	
	Water volume in plate L	5.0	5.0	5.0	5.0	
	Water pressure Max. MPa	2.0	2.0	2.0	2.0	
Optional parts	Joint: CMY-Y102SS/LS-G2, CMY-Y202S-G2 Header: CMY-Y104, 108, 1010-G		Joint: CMY-Y102SS/LS-G2, CMY-Y202S-G2 Header: CMY-Y104, 108, 1010-G		Joint: CMY-Y102SS/LS-G2, CMY-Y202S-G2 Header: CMY-Y104, 108, 1010-G	

Notes:

\*1,\*2 Nominal conditions

	Indoor	Inlet water temperature	Pipe length	Level difference
Cooling	27°C D.B./19°C W.B. (81°F D.B./66°F W.B.)	30°C (86°F)	7.5m (24-9/16ft.)	0m (0ft.)
Heating	20°C D.B. (68°F D.B.)	20°C (68°F)		

\*The ambient temperature of the heat source unit needs to be kept below 40°C D.B.

\*The ambient relative humidity of the heat source unit needs to be kept below 80%.

\*The heat source unit should not be installed at outdoor.

\*Be sure to mount a strainer (more than 50 meshes) at the water inlet piping of the unit.

\*Be sure to provide interlocking for the unit operation and water circuit.

\*When a PFFY-P400/500YM indoor unit is used, the capacity of the indoor unit must not exceed the capacity of the heat source unit. Each indoor unit must be connected to a heat source unit.

\*Nominal condition \*1,\*2 are subject to JIS B8615-2.

\*Due to continuing improvement, above specification may be subject to change without notice.

HEAT SOURCE UNIT

WY-series (Heat pump)

PQHY-P YLM-A1



Specifications

Model		PQHY-P500YLM-A1	PQHY-P550YLM-A1	PQHY-P600YLM-A1	
Power source		3-phase 4-wire 380-400-415 V 50/60 Hz			
Cooling capacity (Nominal)	*1 kW	56.0	63.0	69.0	
	*1 BTU / h	191,100	215,000	235,400	
	Power input kW	11.17	12.54	14.49	
	Current input A	18.8-17.9-17.2	21.1-20.1-19.3	24.4-23.2-22.3	
Temp. range of cooling	EER kW / kW	5.01	5.02	4.76	
	Indoor W.B.	15.0~24.0°C (59~75°F)	15.0~24.0°C (59~75°F)	15.0~24.0°C (59~75°F)	
	Inlet water °C	10.0~45.0°C (50~113°F)	10.0~45.0°C (50~113°F)	10.0~45.0°C (50~113°F)	
Heating capacity (Nominal)	*2 kW	63.0	69.0	76.5	
	*2 BTU / h	215,000	235,400	261,000	
	Power input kW	11.43	12.27	14.51	
	Current input A	19.2-18.3-17.6	20.7-19.6-18.9	24.4-23.2-22.4	
Temp. range of heating	COP kW / kW	5.51	5.62	5.27	
	Indoor D.B.	15.0~27.0°C (59~81°F)	15.0~27.0°C (59~81°F)	15.0~27.0°C (59~81°F)	
	Inlet water °C	10.0~45.0°C (50~113°F)	10.0~45.0°C (50~113°F)	10.0~45.0°C (50~113°F)	
Indoor unit connectable	Total capacity	50~130% of heat source unit capacity	50~130% of heat source unit capacity	50~130% of heat source unit capacity	
	Model / Quantity	P15~P500/1~43	P15~P500/1~47	P15~P600/1~50	
Sound pressure level (measured in anechoic room)	Model				
	dB <A>	54	56.5	56.5	
Refrigerant piping diameter	Liquid pipe mm (in.)	15.88 (5/8) Brazed	15.88 (5/8) Brazed	15.88 (5/8) Brazed	
	Gas pipe mm (in.)	28.58 (1-1/8) Brazed	28.58 (1-1/8) Brazed	28.58 (1-1/8) Brazed	
Circulating water	Water flow rate	m <sup>3</sup> / h	7.20	11.52	
		L/min	120	192	
		cfm	4.2	6.8	
	Pressure drop	kPa	44	45	45
		Operating volume range m <sup>3</sup> / h	4.5 ~ 11.6	6.0 ~ 14.4	6.0 ~ 14.4
Compressor	Type	Inverter scroll hermetic compressor			
	Starting method	Inverter			
	Motor output kW	13.0	15.0	16.1	
	Case heater kW	-	0.045 (240 V)	0.045 (240 V)	
External finish		Galvanized steel sheets			
External dimension HxWxD	mm	1,450 x 880 x 550			
	in.	57-1/8 x 34-11/16 x 21-11/16			
Protection devices	High pressure protection	High pressure sensor, High pressure switch at 4.15 MPa (601 psi)			
	Inverter circuit (COMP.)	Over-heat protection, Over-current protection			
	Compressor	Over-heat protection			
Refrigerant	Type x original charge	R410A x 6.0 kg (14 lbs)	R410A x 11.7 kg (26 lbs)	R410A x 11.7 kg (26 lbs)	
Net weight	kg (lbs)	214 (472)	243 (536)	243 (536)	
Heat exchanger	Water volume in plate		L		
			5.0	10.0	
	Water pressure Max.		MPa		
		2.0	2.0	2.0	
Optional parts		Joint: CMY-Y102SS/LS-G2, CMY-Y202S-G2 Header: CMY-Y104, 108, 1010-G			

Notes:

\*1,\*2 Nominal conditions

	Indoor	Inlet water temperature	Pipe length	Level difference
Cooling	27°C D.B./19°C W.B. (81°F D.B./66°F W.B.)	30°C (86°F)	7.5m (24-9/16ft.)	0m (0ft.)
Heating	20°C D.B. (68°F D.B.)	20°C (68°F)		

\*The ambient temperature of the heat source unit needs to be kept below 40°C D.B.

\*The ambient relative humidity of the heat source unit needs to be kept below 80%.

\*The heat source unit should not be installed at outdoor.

\*Be sure to mount a strainer (more than 50 meshes) at the water inlet piping of the unit.

\*Be sure to provide interlocking for the unit operation and water circuit.

\*When a PFFY-P400/500YM indoor unit is used, the capacity of the indoor unit must not exceed the capacity of the heat source unit. Each indoor unit must be connected to a heat source unit.

\*Nominal condition \*1,\*2 are subject to JIS B8615-2.

\*Due to continuing improvement, above specification may be subject to change without notice.

HEAT SOURCE UNIT

WY-series (Heat pump)

PQHY-P YSLM-A1



Advantages of CITY MULTI

Outdoor/Heat source unit

Indoor unit

Remote Controller

Lossnay

Installation information

Specifications

Model	PQHY-P400YSLM-A1		PQHY-P450YSLM-A1		PQHY-P500YSLM-A1	
Power source	3-phase 4-wire 380-400-415 V 50/60 Hz		3-phase 4-wire 380-400-415 V 50/60 Hz		3-phase 4-wire 380-400-415 V 50/60 Hz	
Cooling capacity (Nominal)	*1 kW	45.0	50.0		56.0	
	*1 BTU / h	153,500	170,600		191,100	
	Power input kW	7.70	8.78		10.12	
	Current input A	12.9-12.3-11.9	14.8-14.0-13.5		17.0-16.2-15.6	
Temp. range of cooling	EER kW / kW	5.84	5.69		5.53	
	Indoor W.B.	15.0~24.0°C (59~75°F)	15.0~24.0°C (59~75°F)		15.0~24.0°C (59~75°F)	
	Inlet water °C	10.0~45.0°C (50~113°F)	10.0~45.0°C (50~113°F)		10.0~45.0°C (50~113°F)	
Heating capacity (Nominal)	*2 kW	50.0	56.0		63.0	
	*2 BTU / h	170,600	191,100		215,000	
	Power input kW	7.94	8.97		10.16	
	Current input A	13.4-12.7-12.2	15.1-14.3-13.8		17.1-16.2-15.7	
Temp. range of heating	COP kW / kW	6.29	6.24		6.20	
	Indoor D.B.	15.0~27.0°C (59~81°F)	15.0~27.0°C (59~81°F)		15.0~27.0°C (59~81°F)	
	Inlet water °C	10.0~45.0°C (50~113°F)	10.0~45.0°C (50~113°F)		10.0~45.0°C (50~113°F)	
Indoor unit connectable	Total capacity Model / Quantity	50~130% of heat source unit capacity P15~P400/1~34	50~130% of heat source unit capacity P15~P400/1~39		50~130% of heat source unit capacity P15~P500/1~43	
	Sound pressure level (measured in anechoic room) dB <A>	49	50		51	
Refrigerant piping diameter	Liquid pipe mm (in.)	15.88 (5/8) Brazed	15.88 (5/8) Brazed		15.88 (5/8) Brazed	
	Gas pipe mm (in.)	28.58 (1-1/8) Brazed	28.58 (1-1/8) Brazed		28.58 (1-1/8) Brazed	

Set Model

Model	PQHY-P200YLM-A1		PQHY-P250YLM-A1		PQHY-P250YLM-A1	
Circulating water	Water flow rate	m <sup>3</sup> / h	5.76 + 5.76		5.76 + 5.76	
		L/min	96 + 96		96 + 96	
		cfm	3.4 + 3.4		3.4 + 3.4	
	Pressure drop	kPa	24	24	24	24
	Operating volume range	m <sup>3</sup> / h	3.0 + 3.0 ~ 7.2 + 7.2		3.0 + 3.0 ~ 7.2 + 7.2	
Compressor	Type	Inverter scroll hermetic compressor		Inverter scroll hermetic compressor		
	Starting method	Inverter		Inverter		
	Motor output	kW	4.8	4.8	6.2	6.2
	Case heater	kW	-	-	-	-
External finish	Galvanized steel sheets					
External dimension HxWxD	mm	1,100 x 880 x 550	1,100 x 880 x 550	1,100 x 880 x 550	1,100 x 880 x 550	1,100 x 880 x 550
	in.	43-5/16 x 34-11/16 x 21-11/16	43-5/16 x 34-11/16 x 21-11/16	43-5/16 x 34-11/16 x 21-11/16	43-5/16 x 34-11/16 x 21-11/16	43-5/16 x 34-11/16 x 21-11/16
Protection devices	High pressure protection	High pressure sensor, High pressure switch at 4.15 MPa (601 psi)		High pressure sensor, High pressure switch at 4.15 MPa (601 psi)		
	Inverter circuit (COMP.)	Over-heat protection, Over-current protection		Over-heat protection, Over-current protection		
	Compressor	Over-heat protection		Over-heat protection		
Refrigerant	Type x original charge	R410A x 5.0 kg (12 lbs)	R410A x 5.0 kg (12 lbs)	R410A x 5.0 kg (12 lbs)	R410A x 5.0 kg (12 lbs)	
Net weight	kg (lbs)	170 (375)	170 (375)	170 (375)	170 (375)	
Heat exchanger	plate type		plate type	plate type	plate type	plate type
	Water volume in plate	L	5.0	5.0	5.0	5.0
	Water pressure Max.	MPa	2.0	2.0	2.0	2.0
Optional parts	Heat Source Twinning kit: CMY-Y100VBK3 Joint: CMY-Y102SS/LS-G2, CMY-Y202S-G2 Header: CMY-Y104, 108, 1010-G		Heat Source Twinning kit: CMY-Y100VBK3 Joint: CMY-Y102SS/LS-G2, CMY-Y202S-G2 Header: CMY-Y104, 108, 1010-G		Heat Source Twinning kit: CMY-Y100VBK3 Joint: CMY-Y102SS/LS-G2, CMY-Y202S-G2 Header: CMY-Y104, 108, 1010-G	

Notes:

\*1,\*2 Nominal conditions

	Indoor	Inlet water temperature	Pipe length	Level difference
Cooling	27°C D.B./19°C W.B. (81°F D.B./66°F W.B.)	30°C (86°F)	7.5m (24-9/16ft.)	0m (0ft.)
Heating	20°C D.B. (68°F D.B.)	20°C (68°F)		

\*The ambient temperature of the heat source unit needs to be kept below 40°C D.B.

\*The ambient relative humidity of the heat source unit needs to be kept below 80%.

\*The heat source unit should not be installed at outdoor.

\*Be sure to mount a strainer (more than 50 meshes) at the water inlet piping of the unit.

\*Be sure to provide interlocking for the unit operation and water circuit.

\*When a PFFY-P400/500YM indoor unit is used, the capacity of the indoor unit must not exceed the capacity of the heat source unit. Each indoor unit must be connected to a heat source unit.

\*Nominal condition \*1,\*2 are subject to JIS B8615-2.

\*Due to continuing improvement, above specification may be subject to change without notice.

HEAT SOURCE UNIT

WY-series (Heat pump)

PQHY-P YSLM-A1



Specifications

Model	PQHY-P550YSLM-A1		PQHY-P600YSLM-A1		PQHY-P700YSLM-A1	
Power source	3-phase 4-wire 380-400-415 V 50/60 Hz		3-phase 4-wire 380-400-415 V 50/60 Hz		3-phase 4-wire 380-400-415 V 50/60 Hz	
Cooling capacity (Nominal)	*1 kW	63.0	69.0		80.0	
	*1 BTU / h	215,000	235,400		273,000	
	Power input kW	11.55	12.84		14.73	
	Current input A	19.4-18.5-17.8	21.6-20.5-19.8		24.8-23.6-22.7	
Temp. range of cooling	EER kW / kW	5.45	5.37		5.43	
	Indoor W.B.	15.0~24.0°C (59~75°F)	15.0~24.0°C (59~75°F)		15.0~24.0°C (59~75°F)	
	Inlet water °C	10.0~45.0°C (50~113°F)	10.0~45.0°C (50~113°F)		10.0~45.0°C (50~113°F)	
Heating capacity (Nominal)	*2 kW	69.0	76.5		88.0	
	*2 BTU / h	235,400	261,000		300,300	
	Power input kW	11.31	12.75		14.73	
	Current input A	19.0-18.1-17.4	21.5-20.4-19.7		24.8-23.6-22.7	
Temp. range of heating	COP kW / kW	6.10	6.00		5.97	
	Indoor D.B.	15.0~27.0°C (59~81°F)	15.0~27.0°C (59~81°F)		15.0~27.0°C (59~81°F)	
	Inlet water °C	10.0~45.0°C (50~113°F)	10.0~45.0°C (50~113°F)		10.0~45.0°C (50~113°F)	
Indoor unit connectable	Total capacity Model / Quantity	50~130% of heat source unit capacity P15~P500/1~47	50~130% of heat source unit capacity P15~P600/1~50		50~130% of heat source unit capacity P15~P600/1~50	
	Sound pressure level (measured in anechoic room) dB <A>	55	57		55	
Refrigerant piping diameter	Liquid pipe mm (in.)	15.88 (5/8) Brazed	15.88 (5/8) Brazed		19.05 (3/4) Brazed	
	Gas pipe mm (in.)	28.58 (1-1/8) Brazed	28.58 (1-1/8) Brazed		34.93 (1-3/8) Brazed	

Set Model

Model	PQHY-P300YLM-A1		PQHY-P250YLM-A1		PQHY-P300YLM-A1		PQHY-P300YLM-A1		PQHY-P350YLM-A1		PQHY-P350YLM-A1	
Circulating water	Water flow rate	m <sup>3</sup> / h	5.76 + 5.76		5.76 + 5.76		7.20 + 7.20		7.20 + 7.20		120 + 120	
		L/min	96 + 96		96 + 96		120 + 120		120 + 120		120 + 120	
		cfm	3.4 + 3.4		3.4 + 3.4		4.2 + 4.2		4.2 + 4.2		4.2 + 4.2	
	Pressure drop	kPa	24	24	24	24	44	44	44	44	44	44
Operating volume range	m <sup>3</sup> / h	3.0 + 3.0 ~ 7.2 + 7.2		3.0 + 3.0 ~ 7.2 + 7.2		4.5 + 4.5 ~ 11.6 + 11.6		4.5 + 4.5 ~ 11.6 + 11.6		4.5 + 4.5 ~ 11.6 + 11.6		
	Type	Inverter scroll hermetic compressor		Inverter scroll hermetic compressor		Inverter scroll hermetic compressor		Inverter scroll hermetic compressor		Inverter scroll hermetic compressor		
Compressor	Starting method	Inverter		Inverter		Inverter		Inverter		Inverter		
	Motor output	kW	7.7	6.2	7.7	7.7	9.5	9.5	9.5	9.5	9.5	
	Case heater	kW	-	-	-	-	-	-	-	-	-	
External finish	Galvanized steel sheets		Galvanized steel sheets		Galvanized steel sheets		Galvanized steel sheets		Galvanized steel sheets		Galvanized steel sheets	
External dimension HxWxD	mm	1,100 x 880 x 550	1,100 x 880 x 550	1,100 x 880 x 550	1,100 x 880 x 550	1,450 x 880 x 550	1,450 x 880 x 550	1,450 x 880 x 550	1,450 x 880 x 550	1,450 x 880 x 550	1,450 x 880 x 550	
		in.	43-5/16 x 34-11/16 x 21-11/16	43-5/16 x 34-11/16 x 21-11/16	43-5/16 x 34-11/16 x 21-11/16	43-5/16 x 34-11/16 x 21-11/16	57-1/8 x 34-11/16 x 21-11/16	57-1/8 x 34-11/16 x 21-11/16	57-1/8 x 34-11/16 x 21-11/16	57-1/8 x 34-11/16 x 21-11/16	57-1/8 x 34-11/16 x 21-11/16	
Protection devices	High pressure protection	High pressure sensor, High pressure switch at 4.15 MPa (601 psi)		High pressure sensor, High pressure switch at 4.15 MPa (601 psi)		High pressure sensor, High pressure switch at 4.15 MPa (601 psi)		High pressure sensor, High pressure switch at 4.15 MPa (601 psi)		High pressure sensor, High pressure switch at 4.15 MPa (601 psi)		
	Inverter circuit (COMP.)	Over-heat protection, Over-current protection		Over-heat protection, Over-current protection		Over-heat protection, Over-current protection		Over-heat protection, Over-current protection		Over-heat protection, Over-current protection		
Refrigerant	Compressor	Over-heat protection		Over-heat protection		Over-heat protection		Over-heat protection		Over-heat protection		
	Type x original charge	R410A x 5.0 kg (12 lbs)	R410A x 5.0 kg (12 lbs)	R410A x 5.0 kg (12 lbs)	R410A x 5.0 kg (12 lbs)	R410A x 5.0 kg (12 lbs)	R410A x 5.0 kg (12 lbs)	R410A x 5.0 kg (12 lbs)	R410A x 5.0 kg (12 lbs)	R410A x 5.0 kg (12 lbs)	R410A x 5.0 kg (12 lbs)	
Net weight	kg (lbs)	170 (375)	170 (375)	170 (375)	170 (375)	214 (472)	214 (472)	214 (472)	214 (472)	214 (472)	214 (472)	
Heat exchanger	Water volume in plate	L	5.0	5.0	5.0	5.0	5.0	5.0	5.0	5.0	5.0	
	Water pressure Max.	MPa	2.0	2.0	2.0	2.0	2.0	2.0	2.0	2.0	2.0	
Optional parts	Heat Source Twinning kit: CMY-Y100VBK3 Joint: CMY-Y102SS/LS-G2, CMY-Y202S-G2 Header: CMY-Y104, 108, 1010-G		Heat Source Twinning kit: CMY-Y100VBK3 Joint: CMY-Y102SS/LS-G2, CMY-Y202S-G2 Header: CMY-Y104, 108, 1010-G		Heat Source Twinning kit: CMY-Y100VBK3 Joint: CMY-Y102SS/LS-G2, CMY-Y202S-G2 Header: CMY-Y104, 108, 1010-G		Heat Source Twinning kit: CMY-Y200VBK2 Joint: CMY-Y102SS/LS-G2, CMY-Y202, 302S-G2 Header: CMY-Y104, 108, 1010-G		Heat Source Twinning kit: CMY-Y200VBK2 Joint: CMY-Y102SS/LS-G2, CMY-Y202, 302S-G2 Header: CMY-Y104, 108, 1010-G		Heat Source Twinning kit: CMY-Y200VBK2 Joint: CMY-Y102SS/LS-G2, CMY-Y202, 302S-G2 Header: CMY-Y104, 108, 1010-G	

Notes:

\*1,\*2 Nominal conditions

	Indoor	Inlet water temperature	Pipe length	Level difference
Cooling	27°C D.B./19°C W.B. (81°F D.B./66°F W.B.)	30°C (86°F)	7.5m (24-9/16ft.)	0m (0ft.)
Heating	20°C D.B. (68°F D.B.)	20°C (68°F)		

\*The ambient temperature of the heat source unit needs to be kept below 40°C D.B.

\*The ambient relative humidity of the heat source unit needs to be kept below 80%.

\*The heat source unit should not be installed at outdoor.

\*Be sure to mount a strainer (more than 50 meshes) at the water inlet piping of the unit.

\*Be sure to provide interlocking for the unit operation and water circuit.

\*When a PFFY-P400/500YM indoor unit is used, the capacity of the indoor unit must not exceed the capacity of the heat source unit. Each indoor unit must be connected to a heat source unit.

\*Nominal condition \*1,\*2 are subject to JIS B8615-2.

\*Due to continuing improvement, above specification may be subject to change without notice.

HEAT SOURCE UNIT

WY-series (Heat pump)

PQHY-P YSLM-A1



Advantages of CITY MULTI

Outdoor/Heat source unit

Indoor unit

Remote Controller

Lossnay

Installation information

Specifications

Model			PQHY-P750YSLM-A1	PQHY-P800YSLM-A1
Power source			3-phase 4-wire 380-400-415 V 50/60 Hz	
Cooling capacity (Nominal)	*1	kW	85.0	90.0
	*1	BTU / h	290,000	307,100
Power input		kW	15.64	16.57
		A	26.4-25.0-24.1	27.9-26.5-25.6
	EER	kW / kW	5.43	5.43
Temp. range of cooling	Indoor	W.B.	15.0~24.0°C (59~75°F)	15.0~24.0°C (59~75°F)
	Inlet water	°C	10.0~45.0°C (50~113°F)	10.0~45.0°C (50~113°F)
Heating capacity (Nominal)	*2	kW	95.0	100.0
	*2	BTU / h	324,100	341,200
		kW	15.90	16.75
		A	26.8-25.4-24.5	28.2-26.8-25.8
Temp. range of heating	Indoor	D.B.	15.0~27.0°C (59~81°F)	15.0~27.0°C (59~81°F)
	Inlet water	°C	10.0~45.0°C (50~113°F)	10.0~45.0°C (50~113°F)
Indoor unit connectable	Total capacity		50~130% of heat source unit capacity	50~130% of heat source unit capacity
	Model / Quantity		P15~P600/1~50	P15~P600/1~50
Sound pressure level (measured in anechoic room)		dB <A>	55	55
Refrigerant piping diameter	Liquid pipe	mm (in.)	19.05 (3/4) Brazed	19.05 (3/4) Brazed
	Gas pipe	mm (in.)	34.93 (1-3/8) Brazed	34.93 (1-3/8) Brazed

Set Model

Model			PQHY-P400YLM-A1	PQHY-P350YLM-A1	PQHY-P400YLM-A1	PQHY-P400YLM-A1
Circulating water	Water flow rate	m <sup>3</sup> / h	7.20 + 7.20		7.20 + 7.20	
		L/min	120 + 120		120 + 120	
		cfm	4.2 + 4.2		4.2 + 4.2	
	Pressure drop	kPa	44	44	44	44
Operating volume range	m <sup>3</sup> / h	4.5 + 4.5 ~ 11.6 + 11.6		4.5 + 4.5 ~ 11.6 + 11.6		
Compressor	Type		Inverter scroll hermetic compressor		Inverter scroll hermetic compressor	
	Starting method		Inverter		Inverter	
	Motor output	kW	10.7	9.5	10.7	10.7
	Case heater	kW	-	-	-	-
External finish		Galvanized steel sheets	Galvanized steel sheets	Galvanized steel sheets	Galvanized steel sheets	
External dimension HxWxD	mm	1,450 x 880 x 550	1,450 x 880 x 550	1,450 x 880 x 550	1,450 x 880 x 550	
	in.	57-1/8 x 34-11/16 x 21-11/16	57-1/8 x 34-11/16 x 21-11/16	57-1/8 x 34-11/16 x 21-11/16	57-1/8 x 34-11/16 x 21-11/16	
Protection devices	High pressure protection	High pressure sensor, High pressure switch at 4.15 MPa (601 psi)		High pressure sensor, High pressure switch at 4.15 MPa (601 psi)		
	Inverter circuit (COMP.)	Over-heat protection, Over-current protection		Over-heat protection, Over-current protection		
Compressor		Over-heat protection		Over-heat protection		
Refrigerant	Type x original charge	R410A x 6.0 kg (14 lbs)	R410A x 6.0 kg (14 lbs)	R410A x 6.0 kg (14 lbs)	R410A x 6.0 kg (14 lbs)	
Net weight	kg (lbs)	214 (472)	214 (472)	214 (472)	214 (472)	
Heat exchanger		plate type		plate type		
	Water volume in plate	L	5.0	5.0	5.0	5.0
	Water pressure Max.	MPa	2.0	2.0	2.0	2.0
Optional parts		Heat Source Twinning kit: CMY-Y200VBK2 Joint: CMY-Y102SS/LS-G2, CMY-Y202, 302S-G2 Header: CMY-Y104, 108, 1010-G		Heat Source Twinning kit: CMY-Y200VBK2 Joint: CMY-Y102SS/LS-G2, CMY-Y202, 302S-G2 Header: CMY-Y104, 108, 1010-G		

Notes:

\*1,\*2 Nominal conditions

	Indoor	Inlet water temperature	Pipe length	Level difference
Cooling	27°C D.B./19°C W.B. (81°F D.B./66°F W.B.)	30°C (86°F)	7.5m (24-9/16ft.)	0m (0ft.)
Heating	20°C D.B. (68°F D.B.)	20°C (68°F)		

\*The ambient temperature of the heat source unit needs to be kept below 40°C D.B.

\*The ambient relative humidity of the heat source unit needs to be kept below 80%.

\*The heat source unit should not be installed at outdoor.

\*Be sure to mount a strainer (more than 50 meshes) at the water inlet piping of the unit.

\*Be sure to provide interlocking for the unit operation and water circuit.

\*When a PFY-P400/500YM indoor unit is used, the capacity of the indoor unit must not exceed the capacity of the heat source unit. Each indoor unit must be connected to a heat source unit.

\*Nominal condition \*1,\*2 are subject to JIS B8615-2.

\*Due to continuing improvement, above specification may be subject to change without notice.



HEAT SOURCE UNIT

**WY-series (Heat pump)**

**PQHY-P YSLM-A1**



**Specifications**

Model			PQHY-P850YSLM-A1	PQHY-P900YSLM-A1
Power source			3-phase 4-wire 380-400-415 V 50/60 Hz	
Cooling capacity (Nominal)	*1 kW		96.0	101.0
	*1 BTU / h		327,600	344,600
	Power input kW		18.03	19.38
	Current input A		30.4-28.9-27.8	32.7-31.0-29.9
	EER kW / kW		5.32	5.21
Temp. range of cooling	Indoor W.B.		15.0~24.0°C (59~75°F)	15.0~24.0°C (59~75°F)
	Inlet water °C		10.0~45.0°C (50~113°F)	10.0~45.0°C (50~113°F)
Heating capacity (Nominal)	*2 kW		108.0	113.0
	*2 BTU / h		368,500	385,600
	Power input kW		18.49	19.74
	Current input A		31.2-29.6-28.5	33.3-31.6-30.5
	COP kW / kW		5.84	5.72
Temp. range of heating	Indoor D.B.		15.0~27.0°C (59~81°F)	15.0~27.0°C (59~81°F)
	Inlet water °C		10.0~45.0°C (50~113°F)	10.0~45.0°C (50~113°F)
Indoor unit connectable	Total capacity		50~130% of heat source unit capacity	50~130% of heat source unit capacity
	Model / Quantity		P15~P600/1~50	P15~P600/1~50
Sound pressure level (measured in anechoic room)	dB <A>		56	57
Refrigerant piping diameter	Liquid pipe mm (in.)		19.05 (3/4) Brazed	19.05 (3/4) Brazed
	Gas pipe mm (in.)		41.28 (1-5/8) Brazed	41.28 (1-5/8) Brazed

**Set Model**

Model			PQHY-P450YLM-A1	PQHY-P400YLM-A1	PQHY-P450YLM-A1	PQHY-P450YLM-A1
Circulating water	Water flow rate	m <sup>3</sup> / h	7.20 + 7.20		7.20 + 7.20	
		L/min	120 + 120		120 + 120	
		cfm	4.2 + 4.2		4.2 + 4.2	
	Pressure drop	kPa	44	44	44	44
Operating volume range	m <sup>3</sup> / h	4.5 + 4.5 ~ 11.6 + 11.6		4.5 + 4.5 ~ 11.6 + 11.6		
Compressor	Type	Inverter scroll hermetic compressor				
	Starting method	Inverter		Inverter		
	Motor output	kW	11.6	10.7	11.6	11.6
	Case heater	kW	-	-	-	-
External finish		Galvanized steel sheets	Galvanized steel sheets	Galvanized steel sheets	Galvanized steel sheets	
External dimension HxWxD	mm	1,450 x 880 x 550	1,450 x 880 x 550	1,450 x 880 x 550	1,450 x 880 x 550	
	in.	57-1/8 x 34-11/16 x 21-11/16	57-1/8 x 34-11/16 x 21-11/16	57-1/8 x 34-11/16 x 21-11/16	57-1/8 x 34-11/16 x 21-11/16	
Protection devices	High pressure protection	High pressure sensor, High pressure switch at 4.15 MPa (601 psi)				
	Inverter circuit (COMP.)	Over-heat protection, Over-current protection		Over-heat protection, Over-current protection		
	Compressor	Over-heat protection		Over-heat protection		
Refrigerant	Type x original charge	R410A x 6.0 kg (14 lbs)	R410A x 6.0 kg (14 lbs)	R410A x 6.0 kg (14 lbs)	R410A x 6.0 kg (14 lbs)	
Net weight	kg (lbs)	214 (472)	214 (472)	214 (472)	214 (472)	
Heat exchanger		plate type		plate type		
	Water volume in plate	L	5.0	5.0	5.0	5.0
	Water pressure Max.	MPa	2.0	2.0	2.0	2.0
Optional parts		Heat Source Twinning kit: CMY-Y200VBK2 Joint: CMY-Y102SS/LS-G2, CMY-Y202, 302S-G2 Header: CMY-Y104, 108, 1010-G		Heat Source Twinning kit: CMY-Y200VBK2 Joint: CMY-Y102SS/LS-G2, CMY-Y202, 302S-G2 Header: CMY-Y104, 108, 1010-G		

**Notes:**

\*1,\*2 Nominal conditions

	Indoor	Inlet water temperature	Pipe length	Level difference
Cooling	27°C D.B./19°C W.B. (81°F D.B./66°F W.B.)	30°C (86°F)	7.5m (24-9/16ft.)	0m (0ft.)
Heating	20°C D.B. (68°F D.B.)	20°C (68°F)		

\*The ambient temperature of the heat source unit needs to be kept below 40°C D.B.

\*The ambient relative humidity of the heat source unit needs to be kept below 80%.

\*The heat source unit should not be installed at outdoor.

\*Be sure to mount a strainer (more than 50 meshes) at the water inlet piping of the unit.

\*Be sure to provide interlocking for the unit operation and water circuit.

\*When a PFY-P400/500YM indoor unit is used, the capacity of the indoor unit must not exceed the capacity of the heat source unit. Each indoor unit must be connected to a heat source unit.

\*Nominal condition \*1,\*2 are subject to JIS B8615-2.

\*Due to continuing improvement, above specification may be subject to change without notice.

## Optional Parts for Heat source unit

Description	Model	Remarks
Branch pipe (Joint)	CMY-Y102SS-G2	200 or below (Total capacity of indoor unit)
	CMY-Y102LS-G2	201~400 (Total capacity of indoor unit)
	CMY-Y202S-G2	401~650 (Total capacity of indoor unit) The first branch of P450-P650
	CMY-Y302S-G2	651 or above (Total capacity of indoor unit)
Branch pipe (Header)	CMY-Y104C-G	For 4 branches
	CMY-Y108C-G	For 8 branches
	CMY-Y1010C-G	For 10 branches
Twinning kit	CMY-Y100VBK3	For PQHY-P400~P600YSLM-A1
	CMY-Y200VBK2	For PQHY-P700~P900YSLM-A1



# Indoor unit

A suitable unit can be selected from among a wide lineup of 17 types of units according to a building's needs. The lineup includes the cassette type, ensuring improved comfort and a pleasant appearance, the ceiling concealed type, excelling in quietness and ensuring flexible placement of air outlets, and the ceiling suspended and wall-mounted types.





# Various installation patterns for indoor situations

## Ceiling Cassette



## Ceiling Concealed



## Other Types



Advantages of CITY MULTI

Outdoor/Heat source unit

Indoor unit

Remote Controller

Lossnay

Installation information

# Wide Selection of Indoor Units

## Ceiling Cassette Type

**4-way airflow type**  
**PLFY-P VEM-PA**



Office Hospital School Restaurant

**Capacity zone** NEW

kW	3.6	4.5	5.6	7.1	9.0	11.2	14.0	16.0
----	-----	-----	-----	-----	-----	------	------	------

>>> P105-P108

**4-way airflow type**  
**PLFY-P VFM-E1**



Office Hospital School Restaurant

**Capacity zone**

kW	1.7	2.2	2.8	3.6	4.5	5.6
----	-----	-----	-----	-----	-----	-----

>>> P109-P112

**2-way airflow type**  
**PLFY-P VLMD-E**



Office Hospital School Residence

**Capacity zone**

kW	2.2	2.8	3.6	4.5	5.6	7.1	9.0	11.2	14.0
----	-----	-----	-----	-----	-----	-----	-----	------	------

>>> P113-P114

**1-way airflow type**  
**PMFY-P VBM-E**  
**PMFY-P VFM-PA** NEW

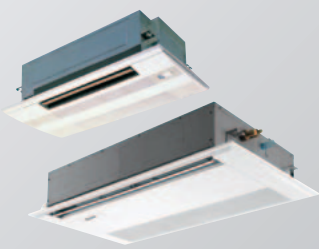

Office School Restaurant Residence

**Capacity zone**

VBM-E (kW)	2.2	2.8	3.6	4.5
VFM-PA (kW)	5.6	7.1	8.0	

>>> P115-P116

## Ceiling Concealed Type

**Low static pressure type**  
**PEFY-P VMS1(L)-E**

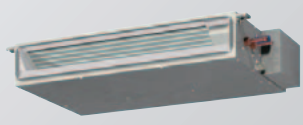

Office Residence Restaurant Hotel

**Capacity zone**

kW	1.7	2.2	2.8	3.6	4.5	5.6	7.1
----	-----	-----	-----	-----	-----	-----	-----

>>> P119-P120

**Medium static pressure type**  
**PEFY-P VMA(L)-E4** NEW  
**PEFY-P VMA3/4-E** NEW

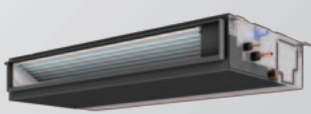

Office School Residence Hotel

**Capacity zone**

VMA(L) (kW)	2.2	2.8	3.6	4.5	5.6	7.1	8.0	9.0	11.2	14.0	16.0
VMA3/4 (kW)	2.2	2.8	3.6	4.5	5.6	7.1	8.0				

>>> P121-P124

**High static pressure type**  
**PEFY-P VMH(S)-E**





Office Hospital School Restaurant

**Capacity zone**

kW	4.5	5.6	7.1	8.0	9.0	11.2	14.0	16.0	22.4	28.0
----	-----	-----	-----	-----	-----	------	------	------	------	------

>>> P125-P126

**Fresh air intake type**  
**PEFY-P VMHS-E-F**



Office Hospital School Restaurant

**Capacity zone**

kW	14.0	22.4	28.0
----	------	------	------

>>> P127-P128

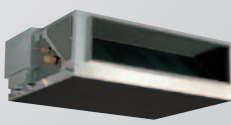
**Fresh air intake type**  
**PEFY-P VMH-E-F**

Office Hospital School Restaurant

**Capacity zone**

kW	9.0	16.0	22.4	28.0
----	-----	------	------	------

>>> P129-P130

**Low noise type**  
**PEFY-P VMR-E-L/R**



Residence Hotel

**Capacity zone**

kW	2.2	2.8	3.6
----	-----	-----	-----



>>> P131-P132



## Other Type

**Ceiling suspended type**

**PCFY-P VKM-E**



**Capacity zone**

kW	4.5	7.1	11.2	14.0
----	-----	-----	------	------

**>>> P133-P134**

**Wall-mounted type**

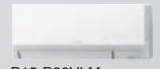
**PKFY-P VLM-E  
PKFY-P VKM-E**

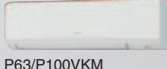

**Capacity zone**

VLM (kW)	1.7	2.2	2.8	3.6	4.5	5.6
VKM (kW)	7.1	11.2				

**>>> P135-P136**

**Floor standing type**

**PFFY-P VKM-E2**



**Capacity zone**

kW	2.2	2.8	3.6	4.5
----	-----	-----	-----	-----

**>>> P137-P138**

**Floor standing type (for perimeter zone)**

**PFFY-P VLEM-E**

**Capacity zone**

kW	2.2	2.8	3.6	4.5	5.6	7.1
----	-----	-----	-----	-----	-----	-----

**>>> P139-P140**

**Floor standing type (for perimeter zone)**

**PFFY-P VCM-E**

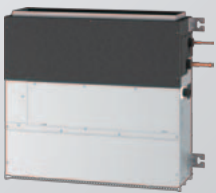



**Capacity zone**

kW	2.2	2.8	3.6	4.5	5.6	7.1
----	-----	-----	-----	-----	-----	-----

**>>> P141-P142**

**Floor standing type**

**PFFY-P YM-E  
PFFY-P YMH-E**



**Capacity zone**

YM (kW)	22.4	28.0	45.0	56.0
YMH (kW)	22.4	28.0		

**>>> P143-P144**

**Floor standing type (freshair intake type)**

**PFFY-P YM-E-F**

**Capacity zone**

kW	33.5	67.0
----	------	------

**>>> P145-P146**

# Ceiling Cassette



# Ceiling Cassette Type

## 4-way airflow type PLFY-P VEM-PA



- Line up expanded up to P140
- The airflow pattern can be selected from 4, 3, or 2 directions
- With the 3D i-see Sensor, "felt temperature\* control" is available, contributing to improve comfort/energy efficiency  
\*i.e., the temperature felt by people in the room

3D i-see Sensor	Decoration Panel	Drain Pump	Air Flow Rate 4 types	Fresh air intake usable
-----------------	------------------	------------	-----------------------	-------------------------

## 4-way airflow type PLFY-P VFM-E1



- 625 mm [24 in.] compact design. Fits perfectly with 2-inch by 2-inch ceiling systems
- With 3D i-see Sensor, smart control based on the number of people in the room is available, contributing to improve comfort/energy efficiency

3D i-see Sensor	Decoration Panel	Drain Pump	Air Flow Rate 3 types	Fresh air intake usable
-----------------	------------------	------------	-----------------------	-------------------------

## 2-way airflow type PLFY-P VLMD-E



- Stylish design with well blended air inlet
- The unit has a height of 290 mm [11-7/16 in.] and can be used in a corridor or narrow room

Decoration Panel	Drain Pump	Air Flow Rate 3 types	Fresh air intake usable
------------------	------------	-----------------------	-------------------------

## 1-way airflow type PMFY-P VBM-E PMFY-P VFM-PA

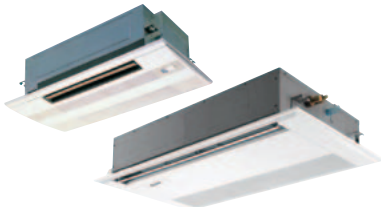

- Line up expanded up to P71
- The 1-way air flow type that is recommended to install on the edges of a room
- Thin design with a height of 230 mm [9-1/16 in.]

Decoration Panel	Drain Pump	Air Flow Rate 4 types	Fresh air intake usable
------------------	------------	-----------------------	-------------------------

### 3D i-see Sensor



The "3D i-see Sensor" built into the optional corner panel eliminates uneven temperature distribution and reduces electricity consumption.

### Highly accurate motion detection

A total of eight sensors rotate a full 360° in 3-minute intervals. In addition to detecting body temperature, our original algorithm also detects the number of occupants in the room and their positions.

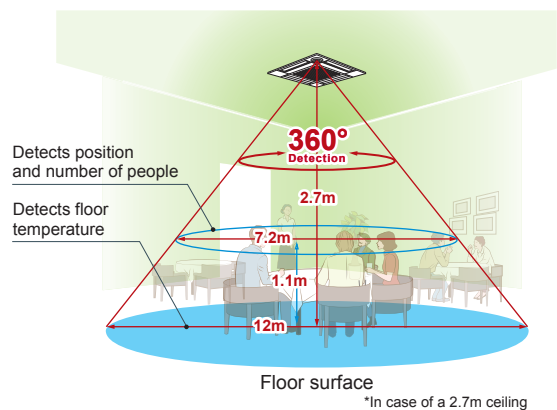



# 4-way airflow type

## PLFY-P VEM-PA



### Optimum Airflow

#### 2-, 3-, 4-way Airflow Pattern Selection

Three outlet options to choose from-bidirectional, 3-way, and 4-way to suit different types of installation. Select, for example, 4-directional for installation in the center of the room and 3-directional for installation in the corner.

2-, 3-, 4-way airflow pattern selection

\* Optional shuffle placement is required for 2- and 3-way patterns.

#### Individual Vane Angle Settings

Vane directions can be changed or fixed from the remote controller to direct the supply air at or away from the objects or the occupants in the room.

Airflow direction at each vane can be set using the wired remote controller or the wireless remote controller (PAR-SL101A-E).

Multi-directional air-conditioning

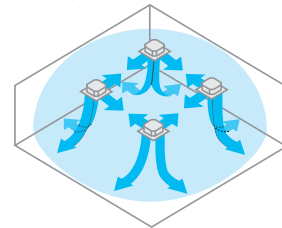

#### 2-, 3-, 4-way Airflow Pattern Selection

#### Individual Vane Angle Settings

The combination of individual vane setting enables the optimal outlet setting for each room layout to ensure even temperature distribution throughout each room. The result is uniformly comfortable air conditioning.

### Equipped with High- and Low-ceiling Modes

Units are equipped with high- and low-ceiling operation modes that make it possible to switch the airflow volume to match a room's height. The ability to choose the optimum airflow volume makes it possible to optimize the breezy sensation felt throughout the room.

4-way airflow with high-ceiling setting

4-way airflow with standard setting

4-way airflow with low-ceiling setting

#### Airflow Range

Airflow pattern	P32-P80			P100/P125/P140		
	High-ceiling setting	Standard setting	Low-ceiling setting	High-ceiling setting	Standard setting	Low-ceiling setting
4-way	3.5 m	2.7 m	2.5 m	4.5 m	3.2 m	2.7 m
3-way	3.5 m	3.0 m	2.7 m	4.5 m	3.6 m	3.0 m
2-way	3.5 m	3.3 m	3.0 m	4.5 m	4.0 m	3.3 m

### Automatic Air-speed Adjustment

An automatic air-speed mode that adjusts airflow speed automatically is adopted to maintain comfortable room conditions at all times. This setting automatically adjusts the air-speed to conditions that match the room environment.

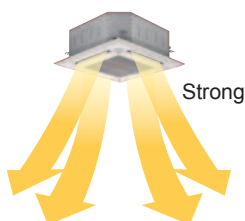

At the start of the heating / cooling operation, the airflow is set to high-speed to quickly heat / cool the room.

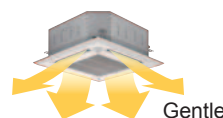

When the room temperature reaches the desired setting, the airflow speed is decreased automatically for stable and comfortable heating/cooling operation.

## 3D i-see Sensor



- Highly accurate people detection

A total of eight sensors rotate a full 360° in 3-minute intervals. In addition to detecting human body temperature, our original algorithm also detects people's positions and the number of people.

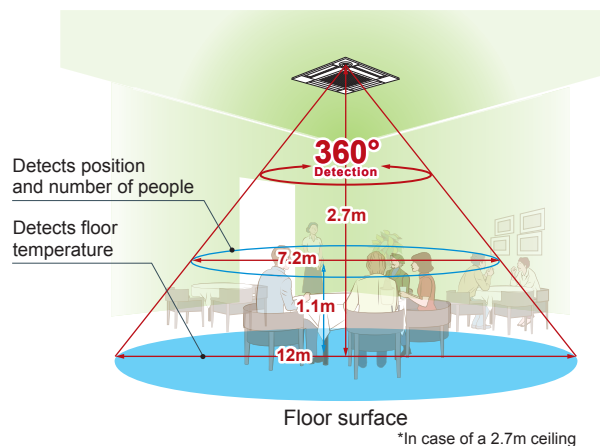
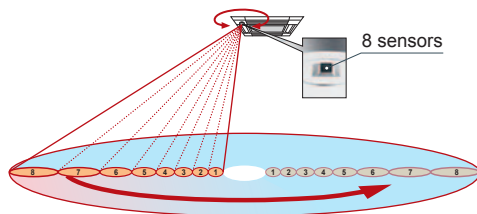

- Detects number of people

### Room occupancy energy-saving mode

The 3D i-see Sensor detects the number of people in the room. It then calculates the occupancy rate based on the maximum number of people in the room up to that point in time in order to save air-conditioning power. Air-conditioning power equivalent to 1°C is saved during both cooling and heating operation at an occupancy rate of approximately 30%. The temperature is controlled according to the number of people.

Room occupancy energy saving mode



### No occupancy energy-saving mode

When 3D i-see Sensor detects that no one is in the room, the system is switched to a preset power-saving mode. If the room remains unoccupied for more than 60min, air-conditioning power equivalent to 2°C is saved during both cooling and heating operation. This contributes to preventing waste in terms of heating and cooling.

No occupancy energy saving mode



### No occupancy Auto-OFF mode

When the room remains unoccupied for a preset period of time, the air conditioner turns off automatically, thereby providing even greater power savings. The time until operation is stopped can be set in intervals of 10min, ranging from 60 to 180 min.

No occupancy Auto-OFF mode



\*No occupancy Auto-OFF mode is not available when multiple indoor units are operated by one MA remote controller.

\*PAR-41MAA is required for each setting.

- Detects people's position

### Direct/Indirect settings\*

Some people do not like the feeling of wind, while others want to be warm from head to toe. People's likes and dislikes vary. With the 3D i-see Sensor, it is possible to choose to block or not block to the wind for each vane.

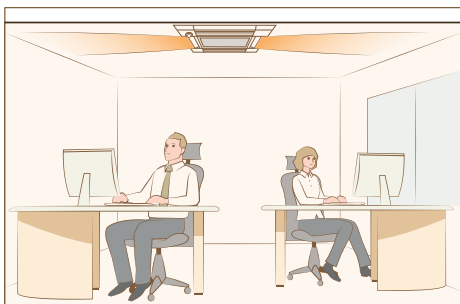

\*PAR-41MAA or PAR-SL101A-E is required for each setting.

### Seasonal airflow\*

#### <When cooling>

Saves energy while keeping a comfortable effective temperature by automatically switching between ventilation and cooling. When a pre-set temperature is reached, the air conditioning unit switches to swing fan operation to maintain the effective temperature. This clever function contributes to keeping a comfortable coolness.

#### <When heating>

The air conditioning unit automatically switches between circulator and heating. Wasted heat that accumulates near the ceiling is reused via circulation. When a pre-set temperature is reached the air conditioner switches from heating to circulator and blows air in the horizontal direction. It pushes down the warm air that has gathered near the ceiling to people's height, thereby providing smart heating.

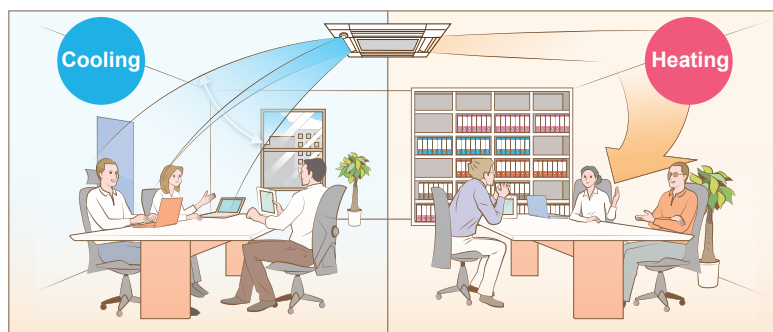

\*PAR-41MAA is required for each setting.



## Easy Installation

### Temporary hanging hook

The structure of the panel has been redesigned and is now equipped with a temporary hanging hook. This has improved work efficiency during panel installation.



### No need to remove screws

Installation is possible without removing the screws for the corner panel and the control box, simply loosen them. This lowers the risk of losing screws.

- Corner panel
- Control box cover



### Electrical box wiring

After reviewing the power supply terminal position in the electrical box, the structure was redesigned to improve connectivity. This has made complex wiring work easier.

- PLFY-P VBM-E → • PLFY-P VEM-PA

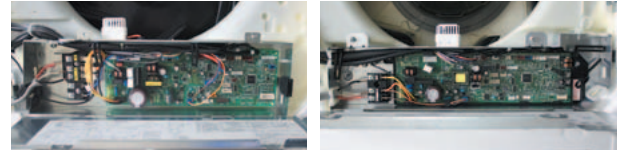

### Increased space for plumbing work

The top and bottom positions of the liquid and gas pipes have been reversed to allow the gas pipe work, which requires more effort, to be completed first. Further, through structural innovations related to the space around the pipes, the area where the spanner can be moved has been increased, thus improving liquid pipe work and enabling it to be completed smoothly.

- PLFY-P VBM-E → • PLFY-P VEM-PA



## Easy Cleaning

With automatic elevation panel, cleaning the filter is easy, even with high ceilings.

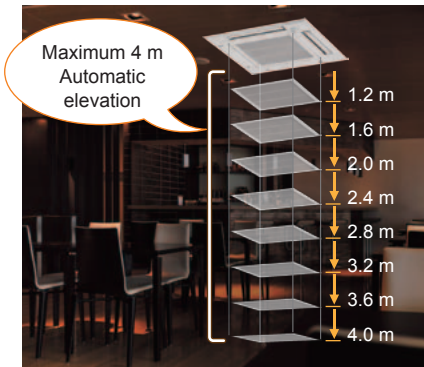

## Connectable to

### Plasma Quad Connect\*

The optional Plasma Quad Connect PAC-SK51FT-E can be installed on the indoor units.

\* Plasma Quad Connect (PAC-SK51FT-E) cannot be used with Auto elevation panel (PLP-6EAJ), Multi functional casement (PAC-SJ41TM-E), and High-efficiency filter element (PAC-SH59KF-E).



## Optional Parts

Description	Model	Applicable capacity
Air outlet shutter plate	PAC-SJ37SP-E	P32, P40, P50, P63, P80, P100, P125, P140
Multi-function casement	PAC-SJ41TM-E	P32, P40, P50, P63, P80, P100, P125, P140
High efficiency filter element	PAC-SH59KF-E	P32, P40, P50, P63, P80, P100, P125, P140
3D i-see Sensor corner panel	PAC-SE1ME-E	P32, P40, P50, P63, P80, P100, P125, P140
Auto elevation and signal receiver panel	PLP-6EAJ	P32, P40, P50, P63, P80, P100, P125, P140
Wireless signal receiver	PAR-SE9FA-E	P32, P40, P50, P63, P80, P100, P125, P140
Space panel	PAC-SJ65AS-E	P32, P40, P50, P63, P80, P100, P125, P140
Duct flange for fresh air intake	PAC-SH65OF-E	P32, P40, P50, P63, P80, P100, P125, P140
Plasma quad connect	PAC-SK51FT-E	P32, P40, P50, P63, P80, P100, P125, P140
Anti-allergy enzyme filter	PAC-SK44KF-E	P32, P40, P50, P63, P80, P100, P125, P140

## Specifications

Model			PLFY-P32VEM-PA	PLFY-P40VEM-PA	PLFY-P50VEM-PA	PLFY-P63VEM-PA
Power source			1-phase 220-240V 50Hz/1-phase 220-230V 60Hz			
Cooling capacity	*1	kW	3.6	4.5	5.6	7.1
	*1	BTU/h	12,300	15,400	19,100	24,200
	Power input	kW	0.03	0.03	0.03	0.03
	Current input	A	0.32	0.32	0.32	0.36
Heating capacity	*2	kW	4.0	5.0	6.3	8.0
	*2	BTU/h	13,600	17,100	21,500	27,300
	Power input	kW	0.03	0.03	0.03	0.03
	Current input	A	0.25	0.25	0.25	0.29
External finish (Munsell No.)	Unit		Galvanized steel sheet			
	Panel		MUNSELL (1.0Y 9.2/0.2)			
External dimension H x W x D	Unit	mm	258 x 840 x 840			
	Panel	mm	40 x 950 x 950			
Net weight	Unit	kg	19			21
	Panel	kg	5			
Heat exchanger			Micro slit fin (Aluminumfin and copper tube)			
Fan			Turbo fan x 1			
Airflow rate (Low-Mid2-Mid1-High)	Type x Quantity					
		m <sup>3</sup> /min	13-14-16-17	13-14-16-18	13-14-16-19	15-16-17-19
		L/s	217-233-267-283	217-233-267-300	217-233-267-317	250-267-283-317
		cfm	459-494-565-600	459-494-565-636	459-494-565-671	530-565-600-671
External static pressure			Pa			
			0			
Motor	Type		DC motor			
	Output	kW	0.050			
Air filter			PP honeycomb			
Sound pressure level (Low-Mid2-Mid1-High)		dB (A)	26-27-29-31	26-27-29-31	26-27-29-31	28-29-30-32
Refrigerant control device			LEV			
Diameter of refrigerant pipe	Liquid	mm (in.)	ø6.35 (ø1/4) Flare			ø9.52 (ø3/8) Flare
	Gas	mm (in.)	ø12.7 (ø1/2) Flare			ø15.88 (ø5/8) Flare
Field drain pipe size		mm (in.)	O.D 32 (1-1/4)			

Model			PLFY-P80VEM-PA	PLFY-P100VEM-PA	PLFY-P125VEM-PA	PLFY-P140VEM-PA <b>NEW</b>
Power source			1-phase 220-240V 50Hz/1-phase 220-230V 60Hz			
Cooling capacity	*1	kW	9.0	11.2	14.0	16.0
	*1	BTU/h	30,700	38,200	47,800	54,600
	Power input	kW	0.05	0.07	0.11	0.11
	Current input	A	0.50	0.67	1.06	1.06
Heating capacity	*2	kW	10.0	12.5	16.0	18.0
	*2	BTU/h	34,100	42,700	54,600	61,400
	Power input	kW	0.05	0.07	0.11	0.11
	Current input	A	0.43	0.60	0.99	0.99
External finish (Munsell No.)	Unit		Galvanized steel sheet			
	Panel		MUNSELL (1.0Y 9.2/0.2)			
External dimension H x W x D	Unit	mm	258 x 840 x 840	298 x 840 x 840		
	Panel	mm	40 x 950 x 950			
Net weight	Unit	kg	21	24		26
	Panel	kg	5			
Heat exchanger			Micro slit fin (Aluminumfin and copper tube)			
Fan			Turbo fan x 1			
Airflow rate (Low-Mid2-Mid1-High)	Type x Quantity					
		m <sup>3</sup> /min	15-18-20-23	20-23-26-29	24-26-30-35	22-27-31-35
		L/s	250-300-333-383	333-383-433-483	400-433-500-583	367-450-517-583
		cfm	530-636-706-812	706-812-918-1024	847-918-1060-1236	777-953-1095-1235
External static pressure			Pa			
			0			
Motor	Type		DC motor			
	Output	kW	0.050	0.120		
Air filter			PP honeycomb			
Sound pressure level (Low-Mid2-Mid1-High)		dB (A)	28-31-34-37	34-37-39-41	35-39-42-45	36-39-42-45
Refrigerant control device			LEV			
Diameter of refrigerant pipe	Liquid	mm (in.)	ø9.52 (ø3/8) Flare			
	Gas	mm (in.)	ø15.88 (ø5/8) Flare			
Field drain pipe size		mm (in.)	O.D 32 (1-1/4)			

### Notes:

- \*1. Nominal cooling conditions  
Indoor: 27°CDB./19°CWB. (81°FDB./66°FWB.), Outdoor: 35°CDB. (95°FDB.)  
Pipe length: 7.5 m (24-9/16 ft.), Level difference: 0 m (0 ft.)
- \*2. Nominal heating conditions  
Indoor: 20°CDB. (68°FDB.), Outdoor: 7°CDB./6°CWB. (45°FDB./43°FWB.)  
Pipe length: 7.5 m (24-9/16 ft.), Level difference: 0 m (0 ft.)

## 4-way airflow type

### PLFY-P VFM-E1



### Beautiful square design

The straight square design matches 2 × 2 (600 mm × 600 mm) ceiling construction specifications.

Direct line-based square design enables designs of system ceiling to match the design of direct line type illuminations, thereby creating a beautiful space.

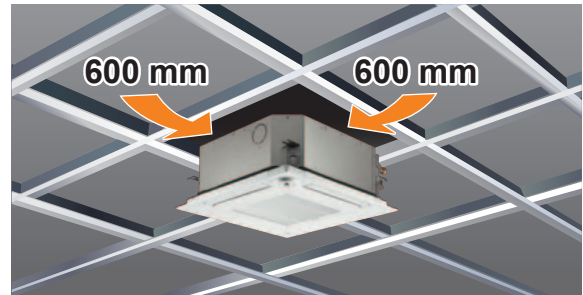

### The height above ceiling 245 mm

The height above ceiling of 245 mm is top class in the industry\*, and enables fitting into narrow ceiling space.

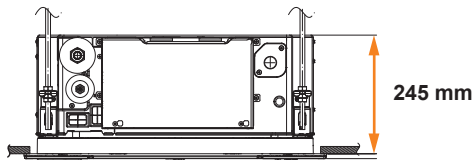

\* As of Aug 2015. Among compact 4-way cassettes for system ceiling. (An incompany investigation.)

### Compact & light-weight design

The panel weighs 3 kg, and the unit's body weighs 14 kg (P15, P20 and P25 models) or 15 kg (P32, P40 and P50 models). Their weight is 5 kg lighter than the PLY-P VEM-E model, allowing them to be easily suspended.

### 3D i-see Sensor

- Highly accurate people detection

A total of eight sensors rotate a full 360° in 3-minute intervals. In addition to detecting human body temperature, our original algorithm also detects people's positions and the number of people.

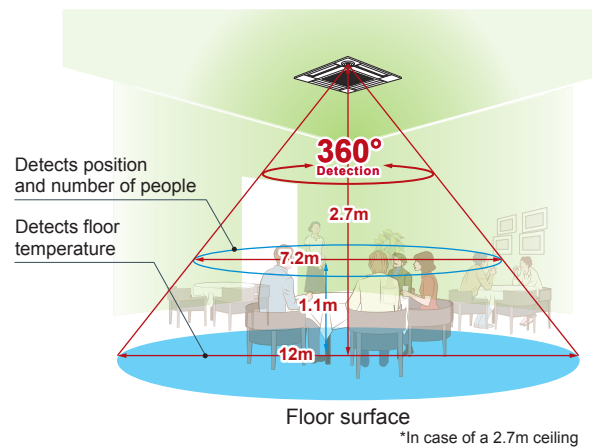
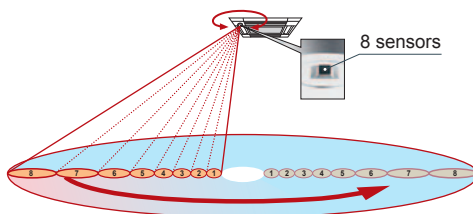

- Detects number of people

### Room occupancy energy-saving mode

The 3D i-see Sensor detects the number of people in the room. It then calculates the occupancy rate based on the maximum number of people in the room up to that point in time in order to save air-conditioning power. Air-conditioning power equivalent to 1°C is saved during both cooling and heating operation at an occupancy rate of approximately 30%. The temperature is controlled according to the number of people.

Room occupancy energy saving mode



### No occupancy energy-saving mode

When 3D i-see Sensor detects that no one is in the room, the system is switched to a preset power-saving mode. If the room remains unoccupied for more than 60min, air-conditioning power equivalent to 2°C is saved during both cooling and heating operation. This contributes to preventing waste in terms of heating and cooling.

No occupancy energy saving mode

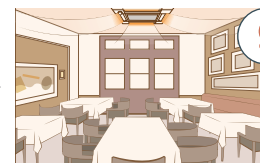

### No occupancy Auto-OFF mode

When the room remains unoccupied for a preset period of time, the air conditioner turns off automatically, thereby providing even greater power savings. The time until operation is stopped can be set in intervals of 10min, ranging from 60 to 180 min.

No occupancy Auto-OFF mode

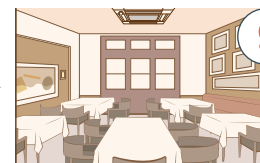

\*No occupancy Auto-OFF mode is not available when multiple indoor units are operated by one MA remote controller.

\*PAR-41MAA is required for each setting.

- Detects people's position

### Direct/Indirect settings\*

Some people do not like the feeling of wind, while others want to be warm from head to toe. People's likes and dislikes vary. With the 3D i-see Sensor, it is possible to choose to block or not block to the wind for each vane.

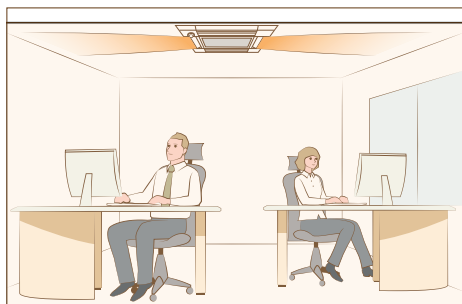

\*PAR-41MAA or PAR-SL101A-E is required for each setting.

### Seasonal airflow\*

#### <When cooling>

Saves energy while keeping a comfortable effective temperature by automatically switching between ventilation and cooling. When a pre-set temperature is reached, the air conditioning unit switches to swing fan operation to maintain the effective temperature. This clever function contributes to keeping a comfortable coolness.

#### <When heating>

The air conditioning unit automatically switches between circulator and heating. Wasted heat that accumulates near the ceiling is reused via circulation. When a pre-set temperature is reached the air conditioner switches from heating to circulator and blows air in the horizontal direction. It pushes down the warm air that has gathered near the ceiling to people's height, thereby providing smart heating.

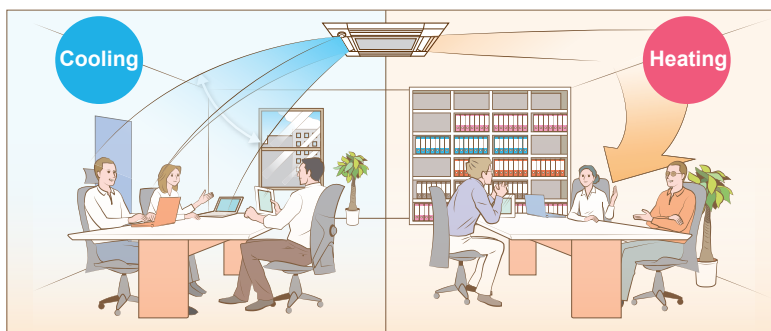

\*PAR-41MAA is required for each setting.

## Anti-Allergy Enzyme Filter NEW

The optional anti-allergy enzyme filter PAC-SK46KF-E contains artificial enzymes to filter out or reduce the level of bacteria<sup>\*1</sup>, viruses<sup>\*2</sup>, and allergens (pollen)<sup>\*3</sup>.

### It can be easily added to units that have already been installed<sup>\*4</sup>.

\* This is effective against bacteria that are attached to the filter surface for 18 hours and viruses that are attached to the filter surface for 24 hours. However, it does not actively remove them from the room itself.

Anti-bacterial Removes viruses Anti-allergen Removes odors

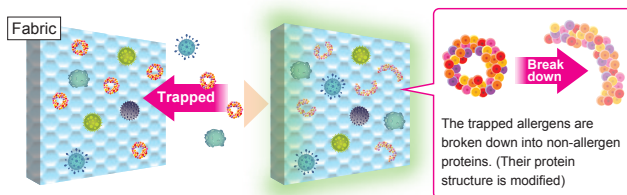

1. The filter fabric traps bacteria, viruses, and allergens.

2. The enzymes inside the filter break down the bacteria, viruses, and allergens to reduce their.

(Image provided for illustrative purposes only.)

\*1: According to tests performed by the Boken Quality Evaluation Institute. Testing procedure: JIS L 1902, Quantitative Test (bacterial solution absorption method). Test number: 006109-1, 2. Target: Two types of bacteria attached to the filter. Test result: At least a 99% reduction after 18 hours compared to untreated fabric. \*2: According to tests performed by the Japan Textile Products Quality and Technology Center. Testing procedure: JIS L 1922, Determination of Antiviral Activity of Textile Products. Test number: 19KB060923-1. Target: One type of virus attached to the filter. Test result: At least a 99% reduction after 24 hours compared to untreated fabric. \*3: According to tests performed by the Japan Food Research Laboratories. Testing procedure: ELISA method. Test number: No. 10014572002-01. Target: One type of pollen attached to the filter. Test result: At least a 99% reduction. \*4: For a list of models that are compatible with this product, please refer to the feature page of each indoor unit.

## Optional Parts

Description	Model	Applicable models
i-see Sensor corner panel	PAC-SF1ME-E	P15, P20, P25, P32, P40, P50
Wireless signal receiver	PAR-SF9FA-E	P15, P20, P25, P32, P40, P50
Anti-allergy enzyme filter	PAC-SK46KF-E	P15, P20, P25, P32, P40, P50

## Panel & Corner panel

		With signal Receiver	With 3D i-see Sensor	With New Wireless
Panel	SLP-2FA			
	SLP-2FAL	●		
	SLP-2FAE		●	
	SLP-2FALE	●	●	
	SLP-2FALM	●		●
	SLP-2FALME	●	●	●
Corner panel	PAR-SF9FA-E	●		
	PAC-SF1ME-E		●	



## Specifications

Model		PLFY-P15VFM-E1	PLFY-P20VFM-E1	PLFY-P25VFM-E1	PLFY-P32VFM-E1	PLFY-P40VFM-E1	PLFY-P50VFM-E1		
Power source		1-phase 220-240V 50Hz/220V 60Hz							
Cooling capacity	*1 kW	1.7	2.2	2.8	3.6	4.5	5.6		
	*1 BTU/h	5,800	7,500	9,600	12,300	15,400	19,100		
Heating capacity	*1 kW	1.9	2.5	3.2	4.0	5.0	6.3		
	*1 BTU/h	6,500	8,500	10,900	13,600	17,100	21,500		
Power consumption	Cooling kW	0.02	0.02	0.02	0.02	0.03	0.04		
	Heating kW	0.02	0.02	0.02	0.02	0.03	0.04		
Current	Cooling A	0.19	0.21	0.22	0.23	0.28	0.40		
	Heating A	0.14	0.16	0.17	0.18	0.23	0.35		
External finish (Munsell No.)	Unit	Galvanized steel sheet							
	Panel	MUNSELL (1.0Y 9.2/0.2)							
Dimension	Unit	208 x 570 x 570 (8-1/4 x 22-1/2 x 22-1/2)							
H x W x D	Panel	10 x 625 x 625 (3/8 x 24-5/8 x 24-5/8)							
Net weight	Unit	14 (31)			15 (33)				
	Panel	3 (7)							
Heat exchanger		Cross fin (Aluminum fin and copper tube)							
Fan	Type x Quantity		Turbo fan x 1						
	Airflow rate (Lo-Mid-Hi)	m <sup>3</sup> /min	6.5-7.5-8.0	6.5-7.5-8.5	6.5-8.0-9.0	7.0-8.0-9.5	7.5-9.0-11.0	9.0-11.0-13.0	
		L/s	108-125-133	108-125-142	108-133-150	117-133-158	125-150-183	150-183-217	
		cfm	230-265-282	230-265-300	230-282-318	247-282-335	265-318-388	318-388-459	
External static pressure		Pa							
Motor		Type							
Output		kW							
Air filter		PP Honeycomb fabric (long life type)							
Refrigerant pipe diameter	Gas (Flare)	mm (in.)							
	Liquid (Flare)	mm (in.)							
Field drain pipe diameter		mm (in.)							
Sound pressure level (Lo-Mid-Hi)		*2	dB (A)	26-28-30	26-29-31	26-30-33	26-30-34	28-33-39	33-39-43

### Notes:

- \*1 Cooling/Heating capacity indicates the maximum value at operation under the following condition.  
Cooling : Indoor 27°C(81°F)DB/19°C(66°F)WB, Outdoor 35°C(95°F)DB  
Heating : Indoor 20°C(68°F)DB, Outdoor 7°C(45°F)DB/6°C(43°F)WB
- \*2 It is measured in anechoic room at power source 230V.

## 2-way airflow type

### PLFY-P VLMD-E



#### Simple panel design

In-take port is not a grille but made in stylish design. It can be installed visually beautifully in harmony with ceiling and illuminations.

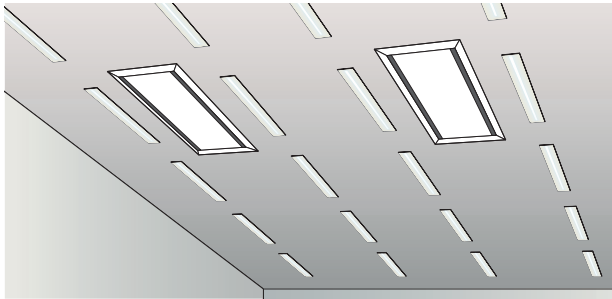

#### Vane Control

Vane angle can be selected from 7 types including "Horizontal fix" and "Swing" to set a airflow type according to your taste.

\*Airflow direction cannot be changed individually.

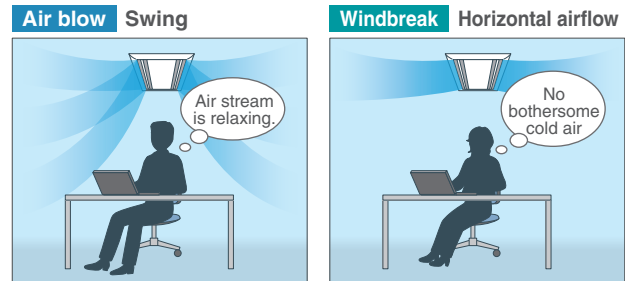

#### Drain pump is equipped as standard feature

The drain can be positioned anywhere up to 583 mm (22-15/16 in.) from the ceiling's surface, providing greater freedom with long cross-piping and allowing more versatility with piping layouts.

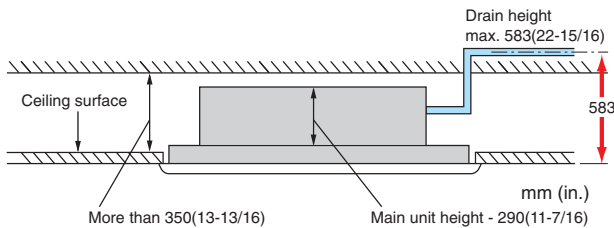

#### Optional Parts

Description	Model	Applicable capacity
Decoration panel	CMP-40VLW-C	P20, P25, P32, P40
	CMP-63VLW-C	P50, P63
	CMP-100VLW-C	P80, P100
	CMP-125VLW-C	P125
OA duct flange	PAC-KH110F	P20, P25, P32, P40, P50, P63, P80, P100

## Specifications

Model			PLFY-P20VLMD-E	PLFY-P25VLMD-E	PLFY-P32VLMD-E	PLFY-P40VLMD-E	
Power source			1-phase 220-240V 50Hz/1-phase 220-230V 60Hz				
Cooling capacity	*1	kW	2.2	2.8	3.6	4.5	
	*1	BTU/h	7,500	9,600	12,300	15,400	
Heating capacity	*1	kW	2.5	3.2	4.0	5.0	
	*1	BTU/h	8,500	10,900	13,600	17,100	
Power consumption	Cooling	kW	0.072/0.075	0.072/0.075	0.072/0.075	0.081/0.085	
	Heating	kW	0.065/0.069	0.065/0.069	0.065/0.069	0.074/0.079	
Current	Cooling	A	0.36/0.37	0.36/0.37	0.36/0.37	0.40/0.42	
	Heating	A	0.30/0.32	0.30/0.32	0.30/0.32	0.34/0.37	
External finish (Munsell No.)	Unit		Galvanized steel plate				
	Panel		Pure white (6.4Y 8.9/0.4)				
Dimension	Unit	mm (in.)	290 x 776 x 634 (11-7/16 x 30-9/16 x 25)				
H x W x D	Panel	mm (in.)	20 x 1080 x 710 (13/16 x 42-9/16 x 28)				
Net weight	Unit	kg (lbs.)	23 (51)		24 (53)		
	Panel	kg (lbs.)	6.5 (15)				
Heat exchanger			Cross fin				
Fan	Type x Quantity		Turbo fan x 1				
	Airflow rate (Lo-Mid-Hi)	*2	m <sup>3</sup> /min	6.5-8.0-9.5		7.0-8.5-10.5	
			L/s	108-133-158		117-142-175	
			cfm	230-283-335		247-300-371	
External static pressure		Pa	0				
Motor	Type		1-phase induction motor				
	Output	kW	0.015 (at 240V)				
Air filter			PP honeycomb fabric (long life type)				
Refrigerant pipe diameter	Gas (Flare)	mm (in.)	ø12.7 (ø1/2)				
	Liquid (Flare)	mm (in.)	ø6.35 (ø1/4)				
Field drain pipe diameter		mm (in.)	O.D.32 (1-1/4)				
Sound pressure level (Lo-Mid-Hi)	220V, 240V	dB (A)	27-30-33		29-33-36		
	*2 *3	230V	28-31-34		30-34-37		

Model			PLFY-P50VLMD-E	PLFY-P63VLMD-E	PLFY-P80VLMD-E	PLFY-P100VLMD-E	PLFY-P125VLMD-E	
Power source			1-phase 220-240V 50Hz/1-phase 220-230V 60Hz					
Cooling capacity	*1	kW	5.6	7.1	9.0	11.2	14.0	
	*1	BTU/h	19,100	24,200	30,700	38,200	47,800	
Heating capacity	*1	kW	6.3	8.0	10.0	12.5	16.0	
	*1	BTU/h	21,500	27,300	34,100	42,700	54,600	
Power consumption	Cooling	kW	0.082/0.086	0.101/0.105	0.147/0.156	0.157/0.186	0.28/0.28	
	Heating	kW	0.075/0.080	0.094/0.099	0.140/0.150	0.150/0.180	0.27/0.27	
Current	Cooling	A	0.41/0.43	0.49/0.51	0.72/0.74	0.75/0.88	1.35/1.35	
	Heating	A	0.35/0.38	0.43/0.46	0.66/0.69	0.69/0.83	1.33/1.33	
External finish (Munsell No.)	Unit		Galvanized steel plate					
	Panel		Pure white (6.4Y 8.9/0.4)					
Dimension	Unit	mm (in.)	290 x 946 x 634 (11-7/16 x 37-1/4 x 25)	290 x 1446 x 634 (11-7/16 x 56-15/16 x 25)	290 x 1750 x 710 (13/16 x 68-15/16 x 28)	290 x 1708 x 606 (11-7/16 x 67-1/4 x 23-7/8)	290 x 2010 x 710 (13/16 x 79-3/16 x 28)	
H x W x D	Panel	mm (in.)	20 x 1250 x 710 (13/16 x 49-1/4 x 28)	20 x 1750 x 710 (13/16 x 68-15/16 x 28)	20 x 1750 x 710 (13/16 x 68-15/16 x 28)	20 x 1750 x 710 (13/16 x 68-15/16 x 28)	20 x 2010 x 710 (13/16 x 79-3/16 x 28)	
Net weight	Unit	kg (lbs.)	27 (60)	28 (62)	44 (98)	47 (104)	56 (124)	
	Panel	kg (lbs.)	7.5 (17)		12.5 (28)		13.0 (29)	
Heat exchanger			Cross fin					
Fan	Type x Quantity		Turbo fan x 1		Turbo fan x 2		Sirocco fan x 4	
	Airflow rate (P50-P100:Lo-Mid-Hi) (P125:Lo-Mid2-Mid1-Hi)	*2	m <sup>3</sup> /min	9.0-11.0-12.5	11.0-13.0-15.5	15.5-18.5-22.0	17.5-21.0-25.0	24.0-27.0-30.0-33.0
			L/s	150-183-208	167-217-258	258-308-367	292-350-417	400-450-500-550
			cfm	318-388-441	353-459-547	547-653-777	618-742-883	848-953-1,059-1,165
External static pressure		Pa	0					
Motor	Type		1-phase induction motor					
	Output	kW	0.020 (at 240V)		0.020 (at 240V)	0.030 (at 240V)	0.078 x 2 (at 240V)	
Air filter			PP honeycomb fabric (long life type)				Synthetic fiber unwoven cloth filter (long life)	
Refrigerant pipe diameter	Gas (Flare)	mm (in.)	ø12.7 (ø1/2)		ø15.88 (ø5/8)			
	Liquid (Flare)	mm (in.)	ø6.35 (ø1/4)		ø9.52 (ø3/8)			
Field drain pipe diameter		mm (in.)	O.D.32 (1-1/4)					
Sound pressure level (Lo-Mid-Hi)	220V, 240V	dB (A)	31-34-37	32-37-39	33-36-39	36-39-42	40-42-44-46	
	*2 *3	230V	32-35-38	33-38-40	34-37-40	37-41-43	(Lo-Mid2-Mid1-Hi)	

### Notes:

\*1 Cooling/Heating capacity indicates the maximum value at operation under the following condition.

Cooling : Indoor 27°C(81°F)DB/19°C(66°F)WB, Outdoor 35°C(95°F)DB

Heating : Indoor 20°C(68°F)DB, Outdoor 7°C(45°F)DB/6°C(43°F)WB

\*2 Airflow rate/Sound pressure level are in (low-middle-high) or (low-middle2-middle1-high).

\*3 It is measured in anechoic room.

# 1-way airflow type

## PMFY-P VBM-E PMFY-P VFM-PA NEW

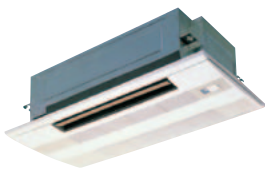

PMFY-P VBM-E (P20-P40)



PMFY-P VFM-PA (P50-P71)



### Ceiling Mounted

Installing a the 1-way airflow type unit in a room creates a more spacious feel that enhances room comfort. This overhead format is also an excellent solution when lighting equipment is installed at the center of the room and fixtures such as book shelves are mounted on wall surfaces.

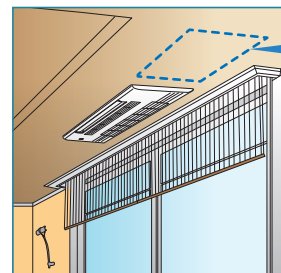

### Expanded line-up

Newly introducing bigger capacity P50-P71 models to suit larger room sizes.

Capacity	P20	P25	P32	P40	P50	P63	P71
Model	PMFY-P VBM				PMFY-P VFM <span style="color: red; font-weight: bold;">NEW</span>		

### Compact size for smooth installation and maintenance(PMFY-P VBM-E)

Unit body size has been standardized for all models at 812 mm for easier installation. Body weight is only 14 kg for the main unit and 3 kg for the panel, making this unit one of the lightest in the industry.

### Drain pump is equipped as standadard feature

The drain can be positioned anywhere up to 600 mm (23-5/8 in.) for P20-40VBM models and 850 mm (33-7/16 in.) for P50-71VFM models from the ceiling's surface.

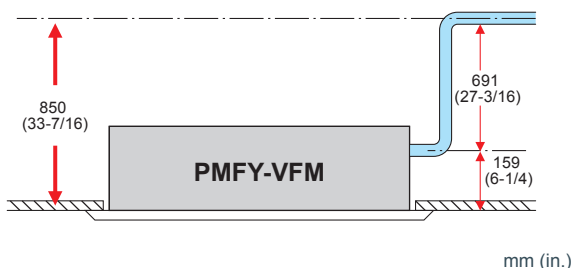
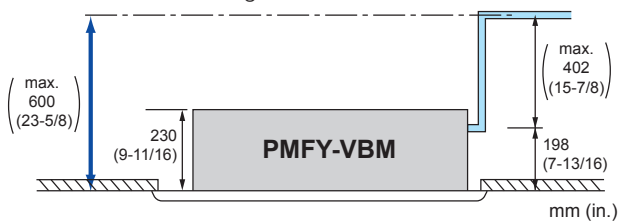

### Easy installation (PMFY-P VFM-PA)

#### Temporary hanging hook

The panel is equipped with a temporary hanging hook. This structure makes work efficiency easier during panel installation.



temporary hanging hook

#### Easy access to suspension bolt

The structure of the panel makes access to suspension bolt easier for height adjustment during installation and maintenance.



### Optional Parts

Description	Model	Applicable capacity
Decoration panel	PMP-40BMW	P20, P25, P32, P40
	PMP-63FMW	P50, P63, P71
Anti-allergy enzyme filter	PAC-SK47KF-E	P50, P63, P71
Left/right airflow direction louver	PAC-SJ15LR-E	P50, P63, P71
External LEV box	PAC-SG95LE-E	P50, P63

# Specifications

Model			PMFY-P20VBM-E	PMFY-P25VBM-E	PMFY-P32VBM-E	PMFY-P40VBM-E	
Power source			1-phase 220-240V 50Hz/1-phase 220V 60Hz				
Cooling capacity	*1	kW	2.2	2.8	3.6	4.5	
	*1	BTU/h	7,500	9,600	12,300	15,400	
Heating capacity	*1	kW	2.5	3.2	4.0	5.0	
	*1	BTU/h	8,500	10,900	13,600	17,100	
Power consumption	Cooling	kW	0.044			0.054	
	Heating	kW	0.042			0.054	
Current	Cooling	A	0.20			0.26	
	Heating	A	0.20			0.26	
External finish (Munsell No.)			White (6.4Y 8.9/0.4)				
Dimension	Unit	mm (in.)	230 x 812 x 395 (9-1/16 x 32 x 15-9/16)				
	Panel	mm (in.)	30 x 1000 x 470 (1-3/16 x 39-3/8 x 18-9/16)				
Net weight	Unit	kg (lbs.)	14 (31)				
	Panel	kg (lbs.)	3 (7)				
Heat exchanger			Cross fin (Aluminum plate fin and copper tube)				
Fan	Type x Quantity		Line flow fan x 1				
	Airflow rate (Lo-Mid2-Mid1-Hi)	*2	m <sup>3</sup> /min	6.5-7.2-8.0-8.7			7.7-8.7-9.7-10.7
			L/s	108-120-133-145			128-145-162-178
		cfm	230-254-283-307			272-307-343-378	
External static pressure	Pa	0					
Motor	Type		1-phase induction motor				
	Output	kW	0.028				
Air filter			PP Honeycomb fabric				
Refrigerant pipe diameter	Gas (Flare)	mm (in.)	ø12.7 (ø1/2)				
	Liquid (Flare)	mm (in.)	ø6.35 (ø1/4)				
Field drain pipe diameter		mm (in.)	O.D. 26 (1)				
Sound pressure level (Lo-Mid2-Mid1-Hi)	*2 *3	dB (A)	27-30-33-35	32-34-36-37	33-35-37-39		

Model			PMFY-P50VFM-PA	PMFY-P63VFM-PA	PMFY-P71VFM-PA	
Power source			1-phase 220-240V 50Hz/1-phase 220-230V 60Hz			
Cooling capacity	*1	kW	5.6	7.1	8.0	
	*1	BTU/h	19,100	24,200	27,300	
Heating capacity	*1	kW	6.3	8.0	9.0	
	*1	BTU/h	21,500	27,300	30,700	
Power consumption	Cooling	kW	0.060			0.090
	Heating	kW	0.045			0.075
Current	Cooling	A	0.47			0.74
	Heating	A	0.42			0.62
External finish (Munsell No.)			White (6.4Y 8.9/0.4)			
Dimension	Unit	mm (in.)	225 x 1112 x 724 (8-7/8 x 43-3/4 x 24-1/2)			
	Panel	mm (in.)	20 x 1340 x 800 (13/16 x 52-3/4 x 31-1/2)			
Net weight	Unit	kg (lbs.)	26 (57)	28 (62)		
	Panel	kg (lbs.)	6.5 (14)			
Heat exchanger			Cross fin (Aluminum plate fin and copper tube)			
Fan	Type x Quantity		Sirocco fan x 2		Sirocco fan x 3	
	Airflow rate (Lo-Mid2-Mid1-Hi)	*2	m <sup>3</sup> /min	11-12-14-16		14-16-17-19
			L/s	183-200-233-267		233-267-300-333
		cfm	388-424-494-565		494-565-600-671	
External static pressure	Pa	0				
Motor	Type		DC motor			
	Output	kW	0.09	0.095		
Air filter			PP honeycomb fabric			
Refrigerant pipe diameter	Gas (Flare)	mm (in.)	ø12.7 (ø1/2)		ø15.88 (ø5/8)	
	Liquid (Flare)	mm (in.)	ø6.35 (ø1/4)		ø9.52 (ø3/8)	
Field drain pipe diameter		mm (in.)	O.D.32 (1-1/4)			
Sound pressure level (Lo-Mid2-Mid1-Hi)	*2 *3	dB (A)	29-32-35-38	32-35-37-39	32-35-38-41	

## Notes:

- \*1 Cooling/Heating capacity indicates the maximum value at operation under the following condition.  
Cooling : Indoor 27°C(81°F)DB/19°C(66°F)WB, Outdoor 35°C(95°F)DB  
Heating : Indoor 20°C(68°F)DB, Outdoor 7°C(45°F)DB/6°C(43°F)WB
- \*2 Airflow rate/Sound pressure level are in (low-middle2-middle1-high).
- \*3 It is measured in anechoic room.



# Ceiling Concealed



## Ceiling Concealed Type

### Low static pressure type

PEFY-P VMS1(L)-E

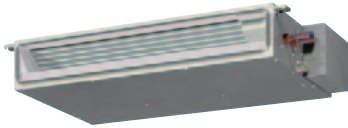

- The thin design with a body height of only 200 mm [7-7/8 in.] (all horsepower models) enables installation in a narrow space in the ceiling
- Low-noise operation
- Compact body with an external static pressure of up to 50 Pa

Static pressure  
up to 50 Pa

Low noise

Height  
200 mm

Drain pump  
(standard)  
up to 550 mm [21-11/16 in.]

Air flow rate  
3 stages

VMS1 model only

### Medium static pressure type

PEFY-P VMA(L)-E4 **NEW**  
PEFY-P VMA3/4-E **NEW**

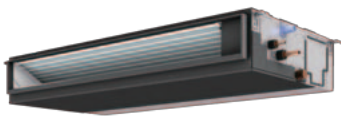

- Thin design of a body height of 250 mm [9-7/8 in.] (all horsepower models)
- The rear or bottom air inlet can be selected
- The drain pump is optionally selectable

Static pressure  
up to 150 Pa

Height  
250 mm

Rear or  
bottom inlet

Drain pump  
(standard)  
up to 700 mm [27-9/16 in.]

Air flow rate  
3 stages

\* The maximum value varies depending on the model.

VMA model only

### High static pressure type

PEFY-P VMH(S)-E



- External static pressure of up to 250 Pa\*<sup>1</sup>, ensuring flexible duct design
- Applicable to drain pumps (option) from 550 mm [21-11/16 in.] to up to 700 mm [27-9/16 in.]

Static pressure  
up to 250 Pa

Drain pump  
option  
up to 700 mm [27-9/16 in.]

Air flow rate  
3 stages\*<sup>2</sup>

\*<sup>1</sup> The maximum value varies depending on the model.  
\*<sup>2</sup> Except VMH Models.

### Fresh air intake type

PEFY-P VMHS-E-F



- Controllable outlet air temperature
- Fresh air intake type indoor unit
- Usable with external static pressures of up to 250 Pa, and available with three different types of air flow

Controllable  
outlet air  
temperature

Static pressure  
up to 250 Pa

Drain pump  
option  
up to 700 mm [27-9/16 in.]

Fresh air  
intake type

Air flow rate  
3 stage

### Fresh air intake type

PEFY-P VMH-E-F



- Fresh air intake type indoor unit
- External static pressure of up to 240 Pa\* expands duct design possibilities

\* P140 model 240 V

Static pressure  
up to 240 Pa

Drain pump  
option  
up to 550 mm [21-11/16 in.]

Fresh air  
intake type

Air flow rate  
1 stage

\* The maximum value varies depending on the model.

### Low noise type

PEFY-P VMR-E-L/R



- Low noise operation. Suitable for spaces where low noise is required such as hotels
- The rear or bottom air inlet can be selected
- The piping connection position can be selected according to the room layout

Static pressure  
5 Pa

Low noise

Rear or  
bottom inlet

Right/Left  
Piping connection

Air flow rate  
3 stages



## Low static pressure type

# PEFY-P VMS1(L)-E

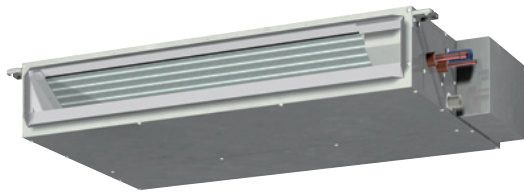

Compact design with a height of only 200 mm [7-7/8 in.] (all models) and a width of 790 mm [31-1/8 in.] (P15 to P32), 990 mm [39 in.] (P40 and P50), or 1190 mm [46-7/8 in.] (P63)

Thin body design with a height of only 200 mm [7-7/8 in.] (all models) enables installation in a narrow space in the ceiling.

PEFY-P VMS1(L)-E		P15	P20	P25	P32	P40	P50	P63
Height	mm [in.]	200 [7-7/8]						
Width	mm [in.]	790 [31-1/8]			990 [39]		1190 [46-7/8]	

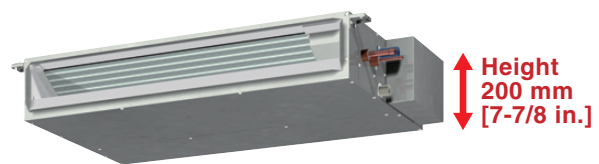

## Low-noise design

The centrifugal fan and coil are designed to reduce noise, making these models suitable for spaces where quietness is required.

Sound pressure level table (Standard static pressure) at 15 Pa dB(A)

Sound Pressure Level	Capacity	dB(A)						
		P15	P20	P25	P32	P40	P50	P63
Fan Speed	High	28	29	30	32	33	35	36
	Mid	24	25	26	27	30	32	33
	Low	22	23	24	24	28	30	30

## Selectable external static pressure

The unit may have a compact body, but its external static pressure can be up to 50 Pa.

The external static pressure can be selected from 5, 15, 35 and 50 Pa.

(The factory default is 15 Pa.)

## Models with and without drain pump are available

PEFY-P VMS1 is provided with a drain pump as standard and does not require a drain trap. PEFY-P VMS1L which is model without drain pump is recommended for places where low-noise operation is required (i.e. hotels)

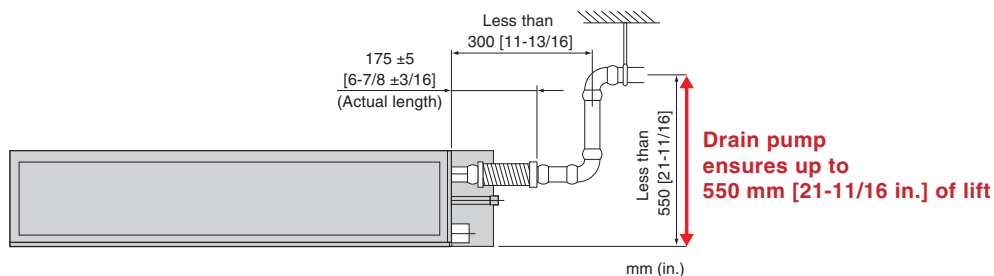

## Connectable to Plasma Quad Connect

The optional Plasma Quad Connect MAC-100FT-E can be installed on the indoor unit's air inlet side. For installation, PQ attachment is required.

## Optional Parts

Description	Model	Applicable capacity
Drain pump*1	PAC-KE07DM-E	P15, 20, 25, 32, 40, 50, 63
Control box replace kit	PAC-KE70HS-E	P15, 20, 25, 32, 40, 50, 63
Plasma quad connect*2	MAC-100FT-E	P15, 20, 25, 32, 40, 50, 63
PQ attachment*2	PAC-HA11PAR	P15, 20, 25, 32, 40, 50, 63

\*1 For PEFY-VMS1L only

\*2 Plasma quad connect (MAC-100FT-E) should be used together with PQ attachment.

## Specifications

Model		PEFY-P15VMS1(L)-E	PEFY-P20VMS1(L)-E	PEFY-P25VMS1(L)-E	PEFY-P32VMS1(L)-E	PEFY-P40VMS1(L)-E	PEFY-P50VMS1(L)-E	PEFY-P63VMS1(L)-E	
Power source		1-phase 220-240V 50Hz/1-phase 220-240V 60Hz							
Cooling capacity	*1 kW	1.7	2.2	2.8	3.6	4.5	5.6	7.1	
	*1 BTU/h	5,800	7,500	9,600	12,300	15,400	19,100	24,200	
Heating capacity	*1 kW	1.9	2.5	3.2	4.0	5.0	6.3	8.0	
	*1 BTU/h	6,500	8,500	10,900	13,600	17,100	21,500	27,300	
Power consumption	*3 Cooling kW	0.05 [0.03]	0.05 [0.03]	0.06 [0.04]	0.07 [0.05]	0.07 [0.05]	0.09 [0.07]	0.09 [0.07]	
	Heating kW	0.03 [0.03]	0.03 [0.03]	0.04 [0.04]	0.05 [0.05]	0.05 [0.05]	0.07 [0.07]	0.07 [0.07]	
Current	*3 Cooling A	0.42 [0.31]	0.47 [0.36]	0.50 [0.39]	0.50 [0.39]	0.56 [0.45]	0.67 [0.56]	0.72 [0.61]	
	Heating A	0.31 [0.31]	0.36 [0.36]	0.39 [0.39]	0.39 [0.39]	0.45 [0.45]	0.56 [0.56]	0.61 [0.61]	
External finish		Galvanized							
Dimension H x W x D	mm	200 x 790 x 700				200 x 990 x 700		200 x 1,190 x 700	
	in.	7-7/8 x 31-1/8 x 27-9/16				7-7/8 x 39 x 27-9/16		7-7/8 x 46-7/8 x 27-9/16	
Net weight	*3 kg (lbs.)	19 (42) [18 (40)]			20 (45) [19 (42)]		24 (53) [23 (51)]		28 (62) [27 (60)]
Heat exchanger		Cross fin (Aluminium fin and copper tube)							
Fan	Type x Quantity	Sirocco fan x 2			Sirocco fan x 3		Sirocco fan x 4		
	Airflow rate (Lo-Mid-Hi)	m <sup>3</sup> /min	5-6-7	5.5-6.5-8	5.5-7-9	6-8-10	8-9.5-11	9.5-11-13	12-14-16.5
		L/s	83-100-117	91-108-133	91-117-150	100-133-167	133-158-183	158-183-217	200-233-275
	External static pressure	cfm	176-212-247	194-229-282	194-247-317	212-282-353	282-335-388	335-388-459	424-494-583
	Pa	5-15-35-50							
Motor	Type	DC motor							
	Output	0.096							
Air filter		PP Honeycomb fabric (washable)							
Refrigerant pipe diameter	Gas	mm (in.)						ø12.7 (ø1/2) Brazed	ø15.88 (ø5/8) Brazed
	Liquid	mm (in.)						ø6.35 (ø1/4) Brazed	ø9.52 (ø3/8) Brazed
Field drain pipe diameter		mm (in.)							O.D. 32 (1-1/4)
Sound pressure level (Lo-Mid-Hi) (measured in anechoic room)		dB (A)	22-24-28	23-25-29	24-26-30	24-27-32	28-30-33	30-32-35	30-33-36

### Notes:

- \*1 Cooling/Heating capacity indicates the maximum value at operation under the following condition.  
Cooling : Indoor : 27°CDB./19°CWB. (81°FDB./66°FWB.) Outdoor : 35°CDB. (95°FDB.)  
Heating : Indoor : 20°CDB. (68°FDB.) Outdoor : 7°CDB./6°CWB. (45°FDB./43°FWB.)  
Pipe length : 7.5m(24-9/16ft) Height difference : 0m(0ft)
- \*2 The external static pressure is set to 15 Pa at factory shipment.
- \*3 [ ] is in case of PEFY-P15-63VMS1L-E

# Medium static pressure type

## PEFY-P VMA(L)-E4 NEW PEFY-P VMA3/4-E NEW

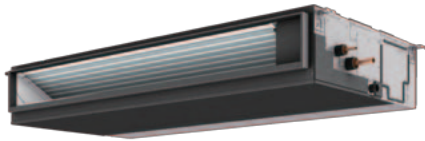

PEFY-P VMA(L)-E4



### Less power consumption

The shape of fan wing and casing is improved to provide more smooth airflow. Besides, the drain pump motor is changed from AC motor to high-efficient DC motor. Operation efficiency is increased by the air flow and motor, which realizes up to 42% reduction in energy consumption (P50/140).

### Comparison of energy consumption in cooling operation

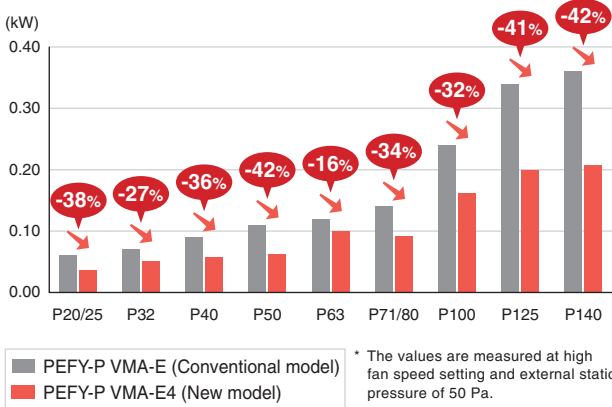

### External static pressure is settable up to 150 Pa (VMA(L)-E4/VMA4-E)

Five-stage external static pressure settings provide flexibility for duct extension, branching, and air outlet configuration and are adjustable to meet different application conditions. Setting ranges to maximum of 150 Pa.

### External static pressure settings

Series	20	25	32	40	50	63	71	80	100	125	140	
PEFY-P VMA(L)-E4	35/50/70/100/150 Pa						40/50/70/100/150 Pa					

### Compact unit requires less installation space (applicable to the PEFY-P63VMA-E4 model only)

The use of new fan with improved air pathway helps to reduce the size of the P63 model unit. The P63 model unit is 200 mm less in width and fits into tighter ceiling space.

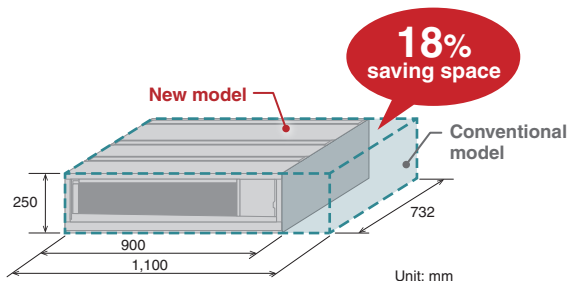

### Air inlet direction can be easily changed

By simply switching the closing board and air filter, the inlet layout can be changed from the rear inlet to the bottom inlet. (At factory shipment: Rear inlet)

### Two air inlet options can be chosen, rear or bottom:

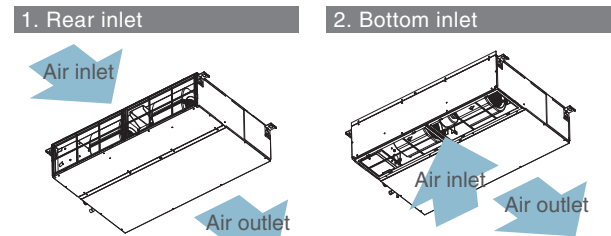

\* Unit with a bottom inlet make more noise than those with a rear inlet. It is recommended that the rear inlet be selected when installing the units in rooms that should be quiet, such as bedrooms.

### Drain pump is optionally selectable

The lineup consists of two types: models with or without a built-in drain pump, thus allowing more freedom in piping layout design.

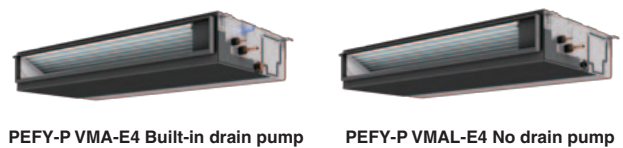

Built-in drain pump PEFY-P VMA-E4, PEFY-P-VMA3/4-E  
No drain pump PEFY-P VMA(L)-E4

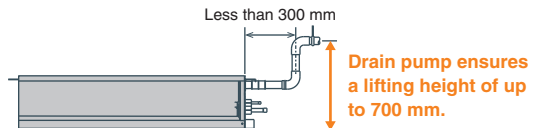

### Large air volume model is available (VMA3/VMA4)

The VMA3/4 lineup offers a selection of models with a larger air volume.



## High power fan speed mode [VMA(L)-E4/VMA4-E] NEW

This start-up mode is run with the increased fan speed for a maximum of 15 minutes to rapidly cool or heat the space (after the first Thermo-ON operation).

- \*1. Power consumption and sound pressure level will increase in this mode.
- \*2. High power fan speed mode is not available when the external static pressure is set to 150 Pa.
- \*3. PAR-41MAA, PAR-U02MEDA, PAR-CT01MAA-S or PAC-YT52CRA is required for this setting. See the instructions and installation manuals for details.

•PAR-41MAA



"HiPower" is displayed on the monitor during high power fan speed mode.

\*High power fan speed mode can be displayed only with PAR-41MAA and PAR-CT01MAA-S.

## Internal dry mode [VMA(L)-E4/VMA4-E] NEW

To dry the heat exchanger (HEX), the unit will operate in the fan mode at high speed after cooling or drying operation has stopped. The drying time is selectable from 30 or 60 minutes.

- \*1. PAR-41MAA, PAR-U02MEDA, PAR-CT01MAA-S or PAC-YT52CRA is required for this setting. See the instructions and installation manuals for details.
- \*2. Air blowing noise is heard during the internal dry operation.
- \*3. To cancel the internal dry operation, start and stop the unit operation within 3 minutes.
- \*4. When using AE-200E's apportioned electricity billing function to apportion electricity consumption of indoor units, do not use the internal dry operation function of indoor units.

### ■Operating Sample

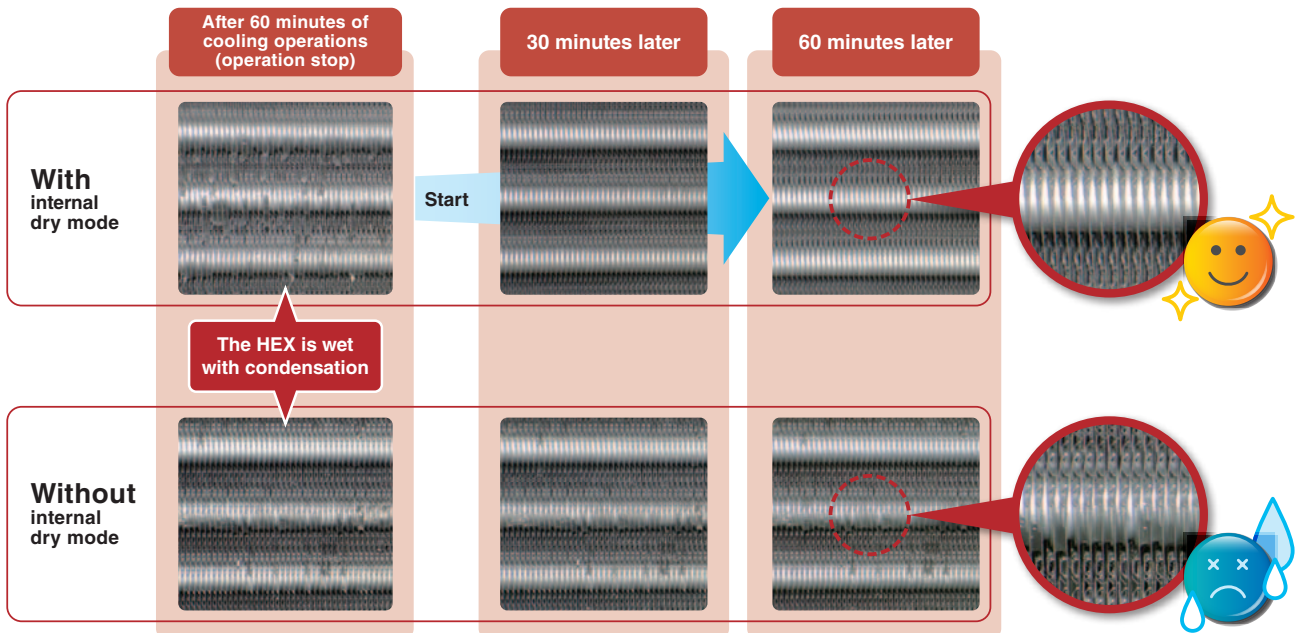

\* Under nominal cooling conditions (Indoor) (27°C D.B./19°C W.B.)  
\* Results will vary depending on indoor temperature and humidity conditions.

## Connectable to *Plasma Quad Connect* [PEFY-P VMA(L)-E4]

The optional Plasma Quad Connect MAC-100FT-E can be installed on the indoor unit's air inlet side. For installation, PQ attachment or PQ box is required.

### Optional Parts

Description	Model	Applicable capacity		
		VMA (L)	VMA4	VMA3
Filter box	PAC-KE91TB-E	P20, P25, P32	—	—
	PAC-KE92TB-E	P40, P50, P63	P20	P20
	PAC-KE93TB-E	P71, P80	P25, P32, P40	—
	PAC-KE94TB-E	P100, P125	—	—
	PAC-KE95TB-E	P140	P50, P63, P71	—
Plasma Quad Connect*	MAC-100FT-E	P20, P25, P32, P40, P50, P63, P71, P80, P100, P125	—	—
PQ attachment (Rear inlet)*	PAC-HA31PAR	P20, P25, P32, P40, P50, P63, P71, P80, P100, P125	—	—
PQ attachment (Bottom inlet)*	PAC-HA31PAU	P20, P25, P32, P40, P50, P63, P71, P80, P100, P125	—	—
PQ box*	PAC-KE91PTB-E	P20, P25, P32	—	—
	PAC-KE92PTB-E	P40, P50, P63	—	—
	PAC-KE93PTB-E	P71, P80	—	—
	PAC-KE94PTB-E	P100, P125	—	—
	PAC-KE95PTB-E	P140	—	—

\*Plasma Quad Connect (MAC-100FT-E) should be used together with PQ attachment or PQ box.

# Specifications

\* [ ] is in case of PEFY-P VMAL-E4.

Model		PEFY-P20VMA(L)-E4	PEFY-P25VMA(L)-E4	PEFY-P32VMA(L)-E4	PEFY-P40VMA(L)-E4	PEFY-P50VMA(L)-E4	PEFY-P63VMA(L)-E4	
Power source		1-phase 220-230-240 V 50/60 Hz						
Cooling capacity (Nominal)	*1 kW	2.2	2.8	3.6	4.5	5.6	7.1	
	*1 BTU/h	7,500	9,600	12,300	15,400	19,100	24,200	
	Power input *2 (220-230-240 V)	0.032 [0.030]	0.032 [0.030]	0.044 [0.042]	0.047 [0.045]	0.066 [0.064]	0.087 [0.085]	
Heating capacity (Nominal)	*2 A	0.26 - 0.25 - 0.24	0.26 - 0.25 - 0.24	0.36 - 0.34 - 0.33	0.39 - 0.37 - 0.36	0.53 - 0.51 - 0.49	0.69 - 0.66 - 0.63	
	*3 kW	2.5	3.2	4.0	5.0	6.3	8.0	
	*3 BTU/h	8,500	10,900	13,600	17,100	21,500	27,300	
External finish	Power input *2 (220-230-240 V)	0.030	0.030	0.042	0.045	0.064	0.085	
	Current input *2 (220-230-240 V)	0.26 - 0.25 - 0.24	0.26 - 0.25 - 0.24	0.36 - 0.34 - 0.33	0.39 - 0.37 - 0.36	0.53 - 0.51 - 0.49	0.69 - 0.66 - 0.63	
	External dimension	Galvanized steel plate						
External dimension	mm	250 x 700 x 732	250 x 700 x 732	250 x 700 x 732	250 x 900 x 732	250 x 900 x 732	250 x 900 x 732	
	in.	9-7/8 x 27-9/16 x 28-7/8	9-7/8 x 27-9/16 x 28-7/8	9-7/8 x 27-9/16 x 28-7/8	9-7/8 x 35-7/16 x 28-7/8	9-7/8 x 35-7/16 x 28-7/8	9-7/8 x 35-7/16 x 28-7/8	
H x W x D								
Net weight	kg (lbs)	21.5 (49) [21 (47)]	21.5 (49) [21 (47)]	21.5 (49) [21 (47)]	26 (58) [25.5 (58)]	26 (58) [25.5 (58)]	27 (60) [26.5 (60)]	
Heat exchanger		Cross fin (Aluminum fin and copper tube)						
FAN	Type x Quantity	Sirocco fan x 1		Sirocco fan x 1		Sirocco fan x 2		
	External static press. *4	Pa	35 - <50> - <70> - <100> - <150>	35 - <50> - <70> - <100> - <150>	35 - <50> - <70> - <100> - <150>	35 - <50> - <70> - <100> - <150>	35 - <50> - <70> - <100> - <150>	
	Motor Type	DC motor						
	Motor output	kW	0.085	0.085	0.085	0.121	0.121	
	Air flow rate (Lo-Mid-Hi)	m <sup>3</sup> /min	6.0 - 7.5 - 8.5	6.0 - 7.5 - 8.5	7.5 - 9.0 - 10.5	10.0 - 12.0 - 14.0	12.0 - 14.5 - 17.0	13.5 - 16.0 - 19.0
		L/s	100 - 125 - 142	100 - 125 - 142	125 - 150 - 175	167 - 200 - 233	200 - 242 - 283	225 - 267 - 317
		cfm	212 - 265 - 300	212 - 265 - 300	265 - 318 - 371	353 - 424 - 494	424 - 512 - 600	477 - 565 - 671
Sound pressure level (measured in anechoic room) (Lo-Mid-Hi) *2 *5	dB <A>	22.0 - 26.0 - 28.0	22.0 - 26.0 - 28.0	24.0 - 28.0 - 31.0	24.0 - 29.0 - 32.0	25.0 - 32.0 - 35.0	28.0 - 32.0 - 36.0	
Air filter		PP honeycomb fabric.						
Refrigerant piping diameter	Liquid (R410A)	mm (in.)	6.35 (1/4) Brazed	6.35 (1/4) Brazed	6.35 (1/4) Brazed	6.35 (1/4) Brazed	6.35 (1/4) Brazed	
	Gas (R410A)	mm (in.)	12.7 (1/2) Brazed	12.7 (1/2) Brazed	12.7 (1/2) Brazed	12.7 (1/2) Brazed	12.7 (1/2) Brazed	
Field drain pipe size	mm (in.)	O.D.32 (1-1/4)	O.D.32 (1-1/4)	O.D.32 (1-1/4)	O.D.32 (1-1/4)	O.D.32 (1-1/4)	O.D.32 (1-1/4)	

Model		PEFY-P71VMA(L)-E4	PEFY-P80VMA(L)-E4	PEFY-P100VMA(L)-E4	PEFY-P125VMA(L)-E4	PEFY-P140VMA(L)-E4	
Power source		1-phase 220-230-240 V 50/60 Hz					
Cooling capacity (Nominal)	*1 kW	8.0	9.0	11.2	14.0	16.0	
	*1 BTU/h	27,300	30,700	38,200	47,800	54,600	
	Power input *2 (220-230-240 V)	0.080 [0.078]	0.080 [0.078]	0.142 [0.140]	0.199 [0.197]	0.208 [0.206]	
Heating capacity (Nominal)	Current input *2 (220-230-240 V)	A	0.60 - 0.57 - 0.55	0.60 - 0.57 - 0.55	1.01 - 0.97 - 0.93	1.29 - 1.23 - 1.18	
	*3 kW	9.0	10.0	12.5	16.0	18.0	
	*3 BTU/h	30,700	34,100	42,700	54,600	61,400	
External finish	Power input *2 (220-230-240 V)	0.078	0.078	0.140	0.197	0.206	
	Current input *2 (220-230-240 V)	A	0.60 - 0.57 - 0.55	0.60 - 0.57 - 0.55	1.01 - 0.97 - 0.93	1.29 - 1.23 - 1.18	
	External dimension	Galvanized steel plate					
External dimension	mm	250 x 1,100 x 732	250 x 1,100 x 732	250 x 1,400 x 732	250 x 1,400 x 732	250 x 1,600 x 732	
	in.	9-7/8 x 43-5/16 x 28-7/8	9-7/8 x 43-5/16 x 28-7/8	9-7/8 x 55-1/8 x 28-7/8	9-7/8 x 55-1/8 x 28-7/8	9-7/8 x 63 x 28-7/8	
H x W x D							
Net weight	kg (lbs)	30 (67) [29.5 (67)]	30 (67) [29.5 (67)]	37.5 (84) [37 (82)]	38.5 (86) [38 (84)]	41.5 (93) [41 (91)]	
Heat exchanger		Cross fin (Aluminum fin and copper tube)					
FAN	Type x Quantity	Sirocco fan x 2		Sirocco fan x 3		Sirocco fan x 3	
	External static press. *4	Pa	40 - <50> - <70> - <100> - <150>	40 - <50> - <70> - <100> - <150>	40 - <50> - <70> - <100> - <150>	<40> - 50 - <70> - <100> - <150>	
	Motor Type	DC motor					
	Motor output	kW	0.121	0.121	0.300	0.300	0.300
	Air flow rate (Lo-Mid-Hi)	m <sup>3</sup> /min	14.5 - 18.0 - 21.0	14.5 - 18.0 - 21.0	23.0 - 28.0 - 32.0	28.0 - 34.0 - 37.0	29.5 - 35.5 - 40.0
		L/s	242 - 300 - 350	242 - 300 - 350	383 - 467 - 533	467 - 567 - 617	492 - 592 - 667
		cfm	512 - 636 - 742	512 - 636 - 742	812 - 989 - 1,130	989 - 1,201 - 1,306	1,042 - 1,254 - 1,412
Sound pressure level (measured in anechoic room) (Lo-Mid-Hi) *2 *5	dB <A>	26.0 - 32.0 - 35.0	26.0 - 32.0 - 35.0	31.0 - 36.0 - 39.0	35.0 - 39.0 - 41.0	34.0 - 38.0 - 41.0	
Air filter		PP honeycomb fabric.					
Refrigerant piping diameter	Liquid (R410A)	mm (in.)	9.52 (3/8) Brazed	9.52 (3/8) Brazed	9.52 (3/8) Brazed	9.52 (3/8) Brazed	
	Gas (R410A)	mm (in.)	15.88 (5/8) Brazed	15.88 (5/8) Brazed	15.88 (5/8) Brazed	15.88 (5/8) Brazed	
Field drain pipe size	mm (in.)	O.D.32 (1-1/4)	O.D.32 (1-1/4)	O.D.32 (1-1/4)	O.D.32 (1-1/4)	O.D.32 (1-1/4)	

## Notes:

- \*1 Nominal cooling conditions  
Indoor: 27°CDB/19°CWB (81°FDB/66°FWB), Outdoor: 35°CDB (95°FDB)  
Pipe length: 7.5 m (24-9/16 ft.), Level difference: 0 m (0 ft.)
- \*2 The values are measured at the factory setting of external static pressure.
- \*3 Nominal heating conditions  
Indoor: 20°CDB (68°FDB), Outdoor: 7°CDB/6°CWB (45°FDB/43°FWB)  
Pipe length: 7.5 m (24-9/16 ft.), Level difference: 0 m (0 ft.)
- \*4 The factory setting of airflow mode and external static pressure mode is shown without < >.  
Refer to "Fan characteristics curves", according to the external static pressure, in DATA BOOK for the usable range of air flow rate.
- \*5 Measured in anechoic room with a 1 m air inlet duct and 2 m air outlet duct attached to the unit and 1.5 m below the unit.

## Specifications (Larger air volume)

Model		PEFY-P20VMA3/4-E	PEFY-P25VMA4-E	PEFY-P32VMA4-E
Power source		1-phase 220-230-240 V 50/60 Hz		
Cooling capacity	*1 kW	2.2	2.8	3.6
	*1 BTU/h	7,500	9,600	12,300
*2 Power input	kW	0.087 [0.110] *6	0.080	0.080
	A	0.69-0.66-0.63 [0.90] *6	0.60-0.57-0.55	0.60-0.57-0.55
Heating capacity	*3 kW	2.5	3.2	4.0
	*3 BTU/h	8,500	10,900	13,600
*2 Power input	kW	0.085 [0.090] *6	0.078	0.078
	A	0.69-0.66-0.63 [0.79] *6	0.60-0.57-0.55	0.60-0.57-0.55
External finish		Galvanized steel plate		
External dimension H x W x D	mm	250 x 900 x 732	250 x 1,100 x 732	250 x 1,100 x 732
	in.	9-7/8 x 35-7/16 x 28-7/8	9-7/8 x 43-5/16 x 28-7/8	9-7/8 x 43-5/16 x 28-7/8
Net weight	kg (lbs.)	27 (60)	30 (67)	30 (67)
Heat exchanger		Cross fin (Aluminum fin and copper tube)		
Fan		Sirocco fan x 2 [x 1] *6		
*4 External static press.	Pa	35-<50>-<70>-<100>-<150> [<35>-50-<70>-<100>-<125>] *6	40-<50>-<70>-<100>-<150>	40-<50>-<70>-<100>-<150>
	mmH <sub>2</sub> O	3.6-<5.1>-<7.1>-<10.2>-<15.3> [<3.6>-5.1-<7.1>-<10.2>-<12.7>] *6	4.1-<5.1>-<7.1>-<10.2>-<15.3>	4.1-<5.1>-<7.1>-<10.2>-<15.3>
Motor Type		DC motor		
Motor output	kW	0.121 [0.085] *6	0.121	0.121
Air flow rate	(Low-Mid-High)			
	m <sup>3</sup> /min	13.5 - 16.0 - 19.0 [12.0 - 14.5 - 17.0] *6	14.5 - 18.0 - 21.0	14.5 - 18.0 - 21.0
	L/s	225 - 267 - 317 [200 - 242 - 283] *6	242 - 300 - 350	242 - 300 - 350
	cfm	477 - 565 - 671 [424 - 512 - 600] *6	512 - 636 - 742	512 - 636 - 742
Sound pressure level (measured in anechoic room)	*2 dB <A>	(Low-Mid-High) 28.0-32.0-36.0 [30.0-35.0-39.0] *6	(Low-Mid-High) 26.0-32.0-35.0	(Low-Mid-High) 26.0-32.0-35.0
Air filter		PP honeycomb fabric.		
Refrigerant piping diameter	Gas (R410A)	mm (in.) 12.7 (1/2)Braze	12.7 (1/2)Braze	12.7 (1/2)Braze
	Liquid (R410A)	mm (in.) 6.35 (1/4)Braze	6.35 (1/4)Braze	6.35 (1/4)Braze
Field drain pipe diameter	mm (in.)	O.D.32 (1-1/4")	O.D.32 (1-1/4")	O.D.32 (1-1/4")

Model		PEFY-P40VMA4-E	PEFY-P50VMA4-E	PEFY-P63VMA4-E	PEFY-P71VMA4-E
Power source		1-phase 220-230-240 V 50/60 Hz			
Cooling capacity	*1 kW	4.5	5.6	7.1	8.0
	*1 BTU/h	15,400	19,100	24,200	27,300
*2 Power input	kW	0.080	0.208	0.208	0.208
	A	0.60-0.57-0.55	1.40-1.34-1.28	1.40-1.34-1.28	1.40-1.34-1.28
Heating capacity	*3 kW	5.0	6.3	8.0	9.0
	*3 BTU/h	17,100	21,500	27,300	30,700
*2 Power input	kW	0.078	0.206	0.206	0.206
	A	0.60-0.57-0.55	1.40-1.34-1.28	1.40-1.34-1.28	1.40-1.34-1.28
External finish		Galvanized steel plate			
External dimension H x W x D	mm	250 x 1,100 x 732	250 x 1,600 x 732	250 x 1,600 x 732	250 x 1,600 x 732
	in.	9-7/8 x 43-5/16 x 28-7/8	9-7/8 x 63 x 28-7/8	9-7/8 x 63 x 28-7/8	9-7/8 x 63 x 28-7/8
Net weight	kg (lbs.)	30 (67)	41.5 (93)	41.5 (93)	41.5 (93)
Heat exchanger		Cross fin (Aluminum fin and copper tube)			
Fan		Sirocco fan x 2			
*4 External static press.	Pa	40-<50>-<70>-<100>-<150>	<40>-50-<70>-<100>-<150>	<40>-50-<70>-<100>-<150>	<40>-50-<70>-<100>-<150>
	mmH <sub>2</sub> O	4.1-<5.1>-<7.1>-<10.2>-<15.3>	<4.1>-5.1-<7.1>-<10.2>-<15.3>	<4.1>-5.1-<7.1>-<10.2>-<15.3>	<4.1>-5.1-<7.1>-<10.2>-<15.3>
Motor Type		DC motor			
Motor output	kW	0.121	0.300	0.300	0.300
Air flow rate	(Low-Mid-High)				
	m <sup>3</sup> /min	14.5 - 18.0 - 21.0	29.5 - 35.5 - 40.0	29.5 - 35.5 - 40.0	29.5 - 35.5 - 40.0
	L/s	242 - 300 - 350	492 - 592 - 667	492 - 592 - 667	492 - 592 - 667
	cfm	512 - 636 - 742	1,042 - 1,254 - 1,412	1,042 - 1,254 - 1,412	1,042 - 1,254 - 1,412
Sound pressure level (measured in anechoic room)	*2 dB <A>	(Low-Mid-High) 26.0-32.0-35.0	(Low-Mid-High) 34.0-38.0-41.0	(Low-Mid-High) 34.0-38.0-41.0	(Low-Mid-High) 34.0-38.0-41.0
Air filter		PP honeycomb fabric.			
Refrigerant piping diameter	Gas (R410A)	mm (in.) 12.7 (1/2)Braze	12.7 (1/2)Braze	15.88 (5/8)Braze	15.88 (5/8)Braze
	Liquid (R410A)	mm (in.) 6.35 (1/4)Braze	6.35 (1/4)Braze	9.52 (3/8)Braze	9.52 (3/8)Braze
Field drain pipe diameter	mm (in.)	O.D.32 (1-1/4")	O.D.32 (1-1/4")	O.D.32 (1-1/4")	O.D.32 (1-1/4")

### Notes:

- \*1 Nominal cooling conditions  
Indoor: 27°C(81°F)DB/19°C(66°F)WB, Outdoor: 35°C(95°F)DB  
Pipe length: 7.5m(24-9/16ft.), Level difference: 0m(0ft.)
- \*2 The values are measured at the factory setting of external static pressure.
- \*3 Nominal heating conditions  
Indoor: 20°C(68°F)DB, Outdoor: 7°C(45°F)DB/6°C(43°F)WB  
Pipe length: 7.5m(24-9/16ft.), Level difference: 0m(0ft.)
- \*4 The factory setting of external static pressure is shown without < > .  
Refer to "Fan characteristics curves", according to the external static pressure, in DATA BOOK for the usable range of air flow rate.
- \*5 Measured in anechoic room with a 1m air inlet duct and 2m air outlet duct attached to the unit and 1.5m below the unit.
- \*6 The figures in [ ] show the specification values of PEFY-P20VMA3-E.

# High static pressure type

## PEFY-P VMH(S)-E



PEFY-P VMH-E



PEFY-P VMHS-E (P40-P140)



PEFY-P VMHS-E (P200/P250)



### Sufficient external static pressure ensuring flexible duct design

Sufficient external static pressure enables designs with long ducts and greatly expands design possibilities. Ducted air-conditioning that matches an interior design can be realized.

PEFY-P VMHS	P40	P50	P63	P71	P80	P100	P125	P140
External static pressure (Pa)	50 - <100> - <150> - <200>							
PEFY-P VMHS-E	P200				P250			
External static pressure (Pa)	<50> - <100> - 150 - <200> - <250>*							

PEFY-P VMH-E	P200	P250
External static pressure (Pa)	380 V	<110> - 220
	400/415 V	<130> - 260

\* The rated external static pressure is shown without < > .  
The factory setting is the rated value.

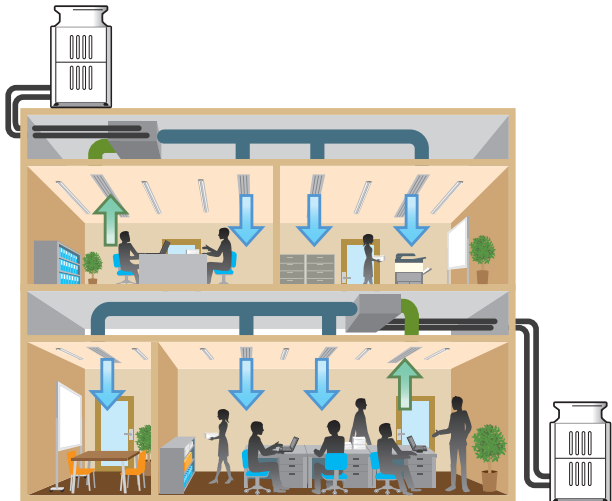

### Use of DC motors (VMHS Models)

These new P40 to P140VMHS Models use DC motors. This reduces the power consumption and weight of the units.

Reduction in weight of units

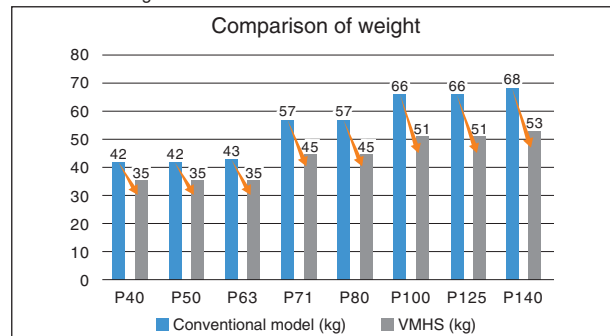

### Drain pump (option) ensures up to 550 mm [21-11/16 in.] for P40-P140VMHS, P200/P250VMH model / 700 mm [27-9/16 in.] for P200/P250VMHS models

The introduction of an upper drain pump allows the drain connection to be raised as high as 550 mm [21-11/16 in.] for P40-P140VMHS, P200/P250VMH models/700 mm [27-9/16 in.] for P200, 500VMHS models, allowing more freedom in piping layout design and reducing horizontal piping requirements.

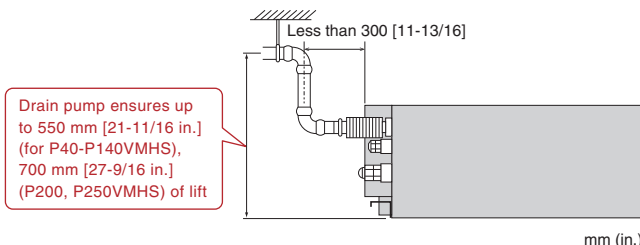

### Optional Parts

Description	Model	Applicable capacity		Remarks
		VMH-E	VMHS-E	
Drain pump	PAC-KE04DM-F	P200, P250	-	
	PAC-KE05DM-F	-	P200, P250	
	PAC-DRP10DP-E2	-	P40-P140	
Long life filter	PAC-KE86LAF	-	P40, P50, P63	
	PAC-KE88LAF	-	P71, P80	
	PAC-KE89LAF	-	P100, P125, P140	
	PAC-KE85LAF	P200, P250	P200, P250	
	PAC-KE63TB-F	-	P40, P50, P63	
Filter box	PAC-KE99TB-F	-	P71, P80	Required when long life filter is used
	PAC-KE140TB-F	-	P100, P125, P140	
	PAC-KE250TB-F	P200, P250	P200, P250	

# Specifications

Model		PEFY-P40VMHS-E	PEFY-P50VMHS-E	PEFY-P63VMHS-E	PEFY-P71VMHS-E	PEFY-P80VMHS-E	PEFY-P100VMHS-E	PEFY-P125VMHS-E	PEFY-P140VMHS-E	
Power source		1-phase 220-230-240 V 50/60 Hz								
Cooling capacity	*1 kW	4.5	5.6	7.1	8.0	9.0	11.2	14.0	16.0	
	*1 BTU/h	15,400	19,100	24,200	27,300	30,700	38,200	47,800	54,600	
	*2 Power input kW	0.055		0.090	0.075	0.090	0.160		0.190	
*2 Current input (220-230-240 V)	A	0.41-0.39-0.38		0.64-0.62-0.59	0.54-0.52-0.50	0.63-0.61-0.58	1.05-1.01-0.96		1.24-1.19-1.14	
	A	0.41-0.39-0.38		0.64-0.62-0.59	0.54-0.52-0.50	0.63-0.61-0.58	1.05-1.01-0.96		1.24-1.19-1.14	
Heating capacity	*3 kW	5.0	6.3	8.0	9.0	10.0	12.5	16.0	18.0	
	*3 BTU/h	17,100	21,500	27,300	30,700	34,100	42,700	54,600	61,400	
	*2 Power input kW	0.055		0.090	0.075	0.090	0.160		0.190	
*2 Current input (220-230-240 V)	A	0.41-0.39-0.38		0.64-0.62-0.59	0.54-0.52-0.50	0.63-0.61-0.58	1.05-1.01-0.96		1.24-1.19-1.14	
	A	0.41-0.39-0.38		0.64-0.62-0.59	0.54-0.52-0.50	0.63-0.61-0.58	1.05-1.01-0.96		1.24-1.19-1.14	
External finish		Galvanized steel plate								
External dimension H x W x D	mm	380 x 745 x 900			380 x 1,030 x 900			380 x 1,195 x 900		
	in.	15 x 29-3/8 x 35-7/16			15 x 40-9/16 x 35-7/16			15 x 47-1/16 x 35-7/16		
Net weight	kg (lbs.)	35 (78)			45 (100)			51 (113)	53 (117)	
Heat exchanger		Cross fin (Aluminum fin and copper tube)								
Fan	Type x Quantity	Sirocco fan x 1				Sirocco fan x 2				
	*4 External static press.	Pa	50-<100>-<150>-<200>				50-<100>-<150>-<200>			
		mmH <sub>2</sub> O	5.1-<10.2>-<15.3>-<20.4>				5.1-<10.2>-<15.3>-<20.4>			
	Motor Type	DC motor								
	Motor output	kW	0.121			0.244		0.375		
	Air flow rate	(Low-Mid-High)								
		m <sup>3</sup> /min	10.0-12.0-14.0	13.5-16.0-19.0	15.5-18.0-22.0	18.0-21.5-25.0	26.5-32.0-38.0	28.0-34.0-40.0		
L/s		167-200-233	225-267-317	258-300-367	300-358-417	442-533-633	467-567-667			
cfm	353-424-494	477-565-671	547-636-777	636-759-883	936-1,130-1,342	989-1,201-1,412				
Sound pressure level (measured in anechoic room)		(Low-Mid-High)								
*2 dB <A>		20-23-27		24-27-32	24-26-30	25-27-30	27-31-34		27-32-36	
		Option:Synthetic fiber unwoven cloth filter (long life filter) and filter box are recommended.								
Air filter		Option:Synthetic fiber unwoven cloth filter (long life filter) and filter box are recommended.								
Refrigerant piping diameter	Gas (R410A)	mm (in.)	12.7 (1/2) Brazed			15.88 (5/8) Brazed				
	Liquid (R410A)	mm (in.)	6.35 (1/4) Brazed			9.52 (3/8) Brazed				
Field drain pipe diameter		mm (in.)	O.D.32 (1-1/4)							

Model		PEFY-P200VMH-E	PEFY-P250VMH-E	PEFY-P200VMHS-E	PEFY-P250VMHS-E	
Power source		3-phase 380-415V 50Hz/3N ~ 380-415V 60Hz		1-phase 220-240V 50Hz/1-phase 220-240V 60Hz		
Cooling capacity	*5 kW	22.4	28.0	22.4	28.0	
	*5 BTU/h	76,400	95,500	76,400	95,500	
Heating capacity	*5 kW	25.0	31.5	25.0	31.5	
	*5 BTU/h	85,300	107,500	85,300	107,500	
Power consumption	Cooling kW	0.99/1.14	1.23/1.41	0.63 *2	0.82 *2	
	Heating kW	0.99/1.14	1.23/1.41	0.63 *2	0.82 *2	
Current	Cooling	380-415V A	2.00/2.30			
		220-230-240V A		3.47-3.32-3.18 *2	4.72-4.43-4.14 *2	
	Heating	380-415V A	1.62/1.86	2.00/2.30		
		220-230-240V A			3.47-3.32-3.18 *2	4.72-4.43-4.14 *2
External finish		Galvanized		Galvanized steel plate		
Dimension H x W x D	mm	470 x 1,250 x 1,120				
	in.	18-9/16 x 49-1/4 x 44-1/8				
Net weight	kg (lbs.)	100 (221)		97 (214)	100 (221)	
Heat exchanger		Cross fin (Aluminum plate fin and copper tube)				
Fan	Type x Quantity	Sirocco fan x 2				
	Airflow rate	m <sup>3</sup> /min	58.0	72.0		
		L/s	967	1200		
		cfm	2048	2543		
	Lo-Mid-Hi	m <sup>3</sup> /min			50.0-61.0-72.0	58.0-71.0-84.0
		L/s			833-1017-1200	967-1183-1400
		cfm			1766-2154-2542	2048-2507-2966
External static pressure	380V Pa	110 · 220 *6				
	400, 415V Pa	130 · 260 *6				
	Pa			<50>-<100>-150-<200>-<250> *9		
	mmH <sub>2</sub> O			<5.1>-<10.2>-15.3-<20.4>-<25.5> *9		
Motor	Type	3-phase induction motor			DC motor	
	Output kW	0.76 *7	1.08 *7	0.87		
Air filter (option)		Synthetic fiber unwoven cloth filter (long life)				
Refrigerant piping diameter	Gas (Brazing)	mm (in.)	ø19.05 (ø3/4)	ø22.2 (ø7/8)	ø19.05 (ø3/4)	
	Liquid (Brazing)	mm (in.)	ø9.52 (ø3/8)			
Field drain pipe diameter		mm (in.)	O.D. 32 (1-1/4)			
Sound pressure level	380V dB (A)	42 (110Pa)/45 (220Pa) *8	50 (110Pa)/52 (220Pa) *8			
	400, 415V dB (A)	44 (130Pa)/47 (260Pa) *8	52 (130Pa)/54 (260Pa) *8			
	Lo-Mid-Hi dB (A)			36-39-43 *10	39-42-46 *10	

## Notes:

- \*1 Nominal cooling conditions  
Indoor: 27°C D.B./19°C W.B. (81°F D.B./66°F W.B.), Outdoor: 35°C D.B. (95°F D.B.)  
Pipe length: 7.5 m (24-9/16 ft.), Level difference: 0 m (0 ft.)
- \*2 The values are measured at the factory setting of external static pressure.
- \*3 Nominal heating conditions  
Indoor: 20°C D.B. (68°F D.B.), Outdoor: 7°C D.B./6°C W.B. (45°F D.B./43°F W.B.)  
Pipe length: 7.5 m (24-9/16 ft.), Level difference: 0 m (0 ft.)
- \*4 The factory setting of external static pressure is shown without < >.  
Refer to "Fan characteristics curves", according to the external static pressure, in DATA BOOK for the usable range of air flow rate.

- \*5 Cooling/heating capacity indicates the maximum value at operation under the following condition.  
Cooling Indoor : 27°C(81°F)DB/19°C(66°F)WB, Outdoor : 35°C(95°F)DB  
Heating Indoor : 20°C(68°F)DB, Outdoor : 7°C(45°F)DB/6°C(43°F)WB
- \*6 The external static pressure is set to 220Pa (at 380V) /260Pa (at 400, 415V) at factory shipment.
- \*7 The value are that at 415V.
- \*8 It is measured in anechoic room.
- \*9 The rated external static pressure is shown without < >.  
The factory setting is the rated value.
- \*10 It is measured at the rated external static pressure in anechoic room.



# Fresh air intake type

## PEFY-P VMHS-E-F



PEFY-P VMHS-E-F (P125)



PEFY-P VMHS-E-F (P200/P250)



### Enables Intake of Outside Air

Fresh air can be taken in with temperature control. Fresh air intake is available for each air-conditioning zone.

\* Fresh air intake type indoor unit is designed to supply pretreated outside air into the room. Do not use to handle internal thermal load.

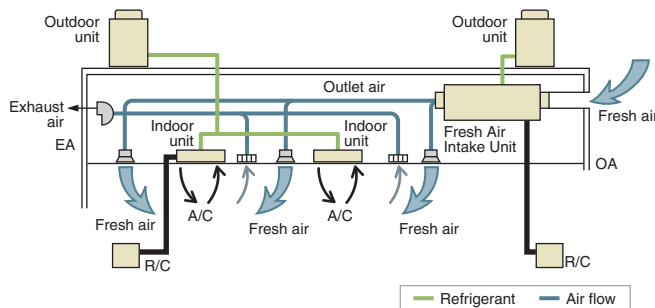

### Flexible Air-Flow Setting

Four levels of external static pressure levels to choose from compared to the three levels on the existing models

Model	P125	P200	P250
External static pressure (Pa)	<100> - <150> - 200 - <250>		

\*The factory setting of external static pressure is shown without chevrons "< >".

Two types of air-flow modes are available, each of which has three air-flow rates to choose from.

Mode	Normal-airflow rate	High-airflow rate
Air-flow rate	Low-Medium-High	Low-Medium-High

\*Air-flow rates are accessible from the remote controller.

### Controllable Outlet Air Temperature

Pre-treating the intake air before being supplied to the room contributes to the stability of room temperature, ensuring optimized comfort of the occupants.

\* Outlet air temperature may fluctuate, depending on the outside air temperature and the operating status of indoor and outdoor units.

### Equipped with DC Fan Motor

Fan motor has been changed to higher efficiency DC motor. Power source has been changed from three-phase power supply to single-phase power supply, which allows for easier installation.

\* Comparison with PEFY-P140, 200, 250VMH-E-F

### Drain Pump (Optional)

Greater design flexibility made possible by the increased head height (Max. 700 mm)\*

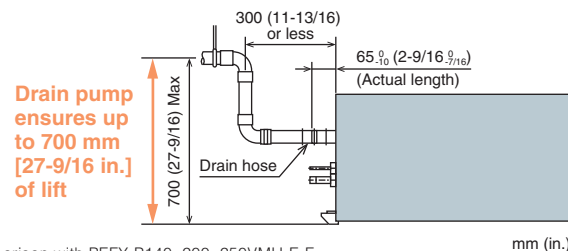

\* Comparison with PEFY-P140, 200, 250VMH-E-F

mm (in.)

## Optional Parts

Description	Model	Applicable capacity
Drain pump kit	PAC-DRP10DP-E2	P125
	PAC-KE06DM-F	P200, 250
Long life filter	PAC-KE89LAF	P125
	PAC-KE85LAF	P200, 250
Filter box	PAC-KE140TB-F	P125
	PAC-KE250TB-F	P200, 250

# Specifications

Model		PEFY-P125VMHS-E-F	PEFY-P200VMHS-E-F	PEFY-P250VMHS-E-F *6
Power source		1-phase 220-230-240 V 50/60 Hz		
Cooling capacity (Nominal)	*1 kW	14.0	22.4	28.0
	*1 BTU/h	47,800	76,400	95,500
Power input	*2 kW	0.220	0.260	0.350
	*2 Current input (220 V)	A	1.43	2.16
Temp. range of cooling		17°CDB./15.5°CWB. ~ 43°CDB./35°CWB. * Thermo-off (FAN-mode) automatically starts if the outdoor temperature is lower than 17°CDB.	17°CDB./15.5°CWB. ~ 43°CDB./35°CWB. * Thermo-off (FAN-mode) automatically starts if the outdoor temperature is lower than 17°CDB.	17°CDB./15.5°CWB. ~ 43°CDB./35°CWB. * Thermo-off (FAN-mode) automatically starts if the outdoor temperature is lower than 17°CDB.
Heating capacity (Nominal)	*3 kW	8.9	13.9	17.4
	*3 BTU/h	30,400	47,400	59,400
Power input	*2 kW	0.230	0.270	0.360
	*2 Current input (220 V)	A	1.52	2.38
Temp. range of heating		-10°CDB. ~ 20°CDB. * Thermo-off (FAN-mode) automatically starts if the outdoor temperature is higher than 20°CDB.	-10°CDB. ~ 20°CDB. * Thermo-off (FAN-mode) automatically starts if the outdoor temperature is higher than 20°CDB.	-10°CDB. ~ 20°CDB. * Thermo-off (FAN-mode) automatically starts if the outdoor temperature is higher than 20°CDB.
External finish		Galvanized		
External dimension HxWxD	mm	380 x 1,195 x 900	470 x 1,250 x 1,120	470 x 1,250 x 1,120
	in.	15 x 47-1/16 x 35-7/16	18-9/16 x 49-1/4 x 44-1/8	18-9/16 x 49-1/4 x 44-1/8
Net weight		kg (lbs.)	49 (109)	78 (172)
Heat exchanger		Cross fin (Aluminum fin and copper tube)		
FAN		Sirocco fan x 1		
*4, 5	Type x Quantity	Sirocco fan x 2		
	External static press. mmH <sub>2</sub> O	<100> - <150> - 200 - <250>	<100> - <150> - 200 - <250>	<100> - <150> - 200 - <250>
Motor Type		DC motor		
Motor output kW		0.244		
Driving mechanism		Direct-driven by motor		
*4, 5	Air flow rate	Normal-airflow rate mode <High-airflow rate mode>	Normal-airflow rate mode <High-airflow rate mode>	Normal-airflow rate mode <High-airflow rate mode>
	(Low-Mid-High)	m <sup>3</sup> /min L/s cfm	14.0 - 15.5 - 18.0 233 - 258 - 300 494 - 547 - 636	15.5 - 18.0 - 20.0 258 - 300 - 333 547 - 636 - 706
Sound pressure level (measured in anechoic room) (Low-Mid-High)		Normal-airflow rate mode <High-airflow rate mode>	Normal-airflow rate mode <High-airflow rate mode>	Normal-airflow rate mode <High-airflow rate mode>
Air filter		Option: Synthetic fiber unwoven cloth filter (long life filter).		
Refrigerant piping diameter	Liquid (R410A)	mm (in.)	9.52 (3/8) Brazed	9.52 (3/8) Brazed
	Gas (R410A)	mm (in.)	15.88 (5/8) Brazed	19.05 (3/4) Brazed
Field drain pipe size		mm (in.)	O.D.32 (1-1/4)	O.D.32 (1-1/4)
Optional parts	Drain pump kit	PAC-DRP10DP-E2		
	Long life filter	PAC-KE89LAF		
	Filter box	PAC-KE140TB-F		

## Notes:

- \*1 Cooling capacity indicates the maximum value at operation under the following condition. Cooling: Indoor 33°CDB/28°CWB, Outdoor 33°CDB. The set temperature of the remote controller is 18°C.
- \*2 The value are measured at the factory setting of airflow mode and external static pressure.
- \*3 Heating capacity indicates the maximum value at operation under the following condition. Heating: Indoor 0°CDB/-2.9°CWB, Outdoor 0°CDB/-2.9°CWB. The set temperature of the remote controller is 25°C.
- \*4 The factory setting of airflow mode and external static pressure mode is shown without < >. Refer to "Fan characteristics curves", according to the external static pressure, in DATA BOOK for the usable range of air flow rate.
- \*5 If the airflow rate is over the usable range, dew drop can be caused from the air outlet and the air flow rate is changed automatically because of the output down by the fan motor control. If the air flow rate is less than the usable range, condensation from the unit surface can be caused.
- \*6 Regarding P250VMHS-E-F, the middle notch air flow rate is different from the spec value when the external static pressure setting is set to 100Pa. See "Fan characteristics curves" in DATA BOOK for the details.
- The combination of fresh air intake type indoor units with other types of indoor units to handle internal thermal load which may cause the conflict of operation mode. It is not recommended when fresh air intake type indoor unit is connected to the Y or WY series.
- Depending on the air conditioning load, outside temperature, and due to the activation of protection functions, the desired preset temperature may not always be achieved and the discharge temperature may swing. Note that untreated outside air may be delivered directly into the room upon the activation of protection functions.
- Fresh air intake type indoor units cannot be connected to PUMY series, except for PUMY-SP125/140V(Y)KM2, PUMY-CP125/140VKM2, PUMY-CP125/140/200/225YKM2, PUMY-P200/225YKM3, PUMY-(C)P250/300YBM2. Fresh air intake type indoor unit and PUMY have to be one to one connection. Fresh air intake type unit cannot be connected to an outdoor unit together with PWFY series.
- The maximum connectable indoor units to 1 outdoor unit are 110% (100% in case of heating below -5°C).
- When fresh air intake type indoor units connect to an outdoor unit together with other types of indoor unit, the total capacity of fresh air intake type indoor units needs to be 30% or less of the connected outdoor unit capacity.
- The AUTO mode on the local remote controller is available only when fresh air intake type indoor unit is connected to the R2 or WR2 series of outdoor unit.
- The system changeover function is available only when all the connected indoor units are fresh air intake type indoor units.
- The fan temporary stops during defrost.
- The cooling and heating capacities are the maximum capacities that were obtained by operating in the above air conditions and with a refrigerant pipe of about 7.5 m and a level difference of 0 m.
- The actual capacity characteristics vary with the combination of indoor and outdoor units. See the technical information in DATA BOOK for the details.
- Thermo off (Fan) operation automatically starts either when temperature is lower than 17°CDB in cooling mode or when the temperature exceeds 20°CDB in heating mode.
- Dry mode is not available.
- When this unit is used as sole A/C system, be careful about the dew in air outlet grilles in cooling mode.
- Un-conditioned outdoor air such as humid air or cold air blows to the indoor during thermo off operation. Please be careful when positioning indoor unit air outlet grilles, ie take the necessary precautions for cold air, and also insulate rooms for dew condensation prevention as required.
- Air filter must be installed in the air intake side. The filter should be attached where easy maintenance is possible in case of usage of field supply filters.

# Fresh air intake type

## PEFY-P VMH-E-F

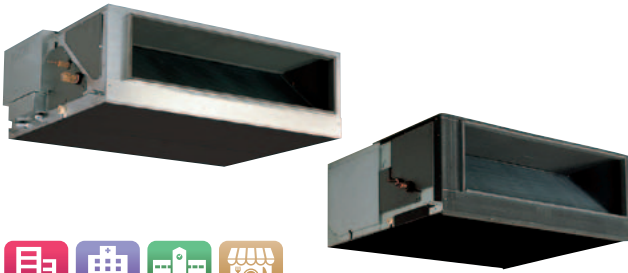

### Example design for an outside air treatment unit system

The Fresh Air intake indoor unit can take fresh outdoor air into any building.

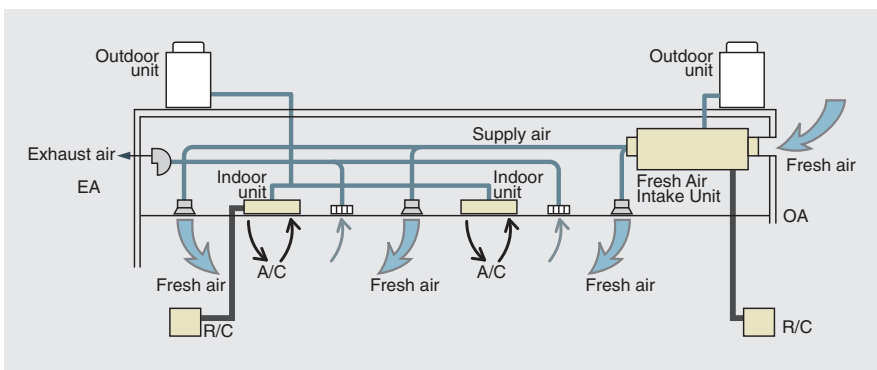

- \* Fresh air intake type indoor unit is designed to supply pretreated outside air into the room. Do not use to handle internal thermal load.
- \* Discharge temperature control is not possible. PEFY-P VMH-E-F models turn the thermo ON or OFF depending on the room temperature. Either a remote controller (sold separately) or a remote sensor (sold separately) must be installed to monitor the room temperature. During thermo-off (FAN-mode), outside air blows directly into the room.

### Applications across a wide range of design

Sufficient external static pressure (up to 240 Pa) enables designs with long ducts and expands design possibilities.

PEFY-P VMH-E-F		P80	P140	P200	P250
External static pressure (Pa)	208 V	<35> - 85 - <170>	<35> - 85 - <170>	<140> - 200	<110> - 190
	220 V	<40> - 115 - <190>	<50> - 115 - <190>	<150> - 210	<120> - 200
	230 V	<50> - 130 - <210>	<60> - 130 - <220>	<160> - 220	<130> - 210
	240 V	<80> - 170 - <220>	<100> - 170 - <240>	-	-

\*The factory setting for external static pressure is shown without "<>".

Refer to "Fan characteristics curves", according to the external static pressure, in the DATA BOOK for the usable range of the air flow rate.

### Drain pump (option) ensures up to 550 mm [21-11/16 in.] of lift

The introduction of an upper drain pump allows the drain connection to be raised as high as 550 mm [21-11/16 in.], allowing more freedom in piping layout design and reducing horizontal piping requirements.

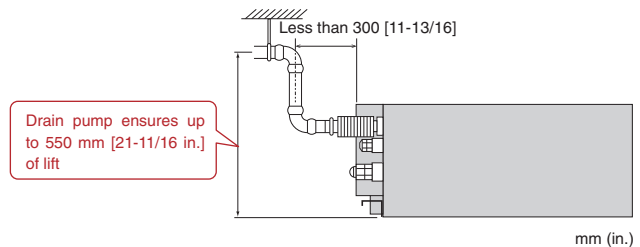

### Optional Parts

Description	Model	Applicable capacity
Long life filter	PAC-KE88LAF	P80
	PAC-KE89LAF	P140
	PAC-KE85LAF	P200, P250
Filter box	PAC-KE80TB-F	P80
	PAC-KE140TB-F	P140
	PAC-KE250TB-F	P200/P250
Drain pump	PAC-KE04DM-F	P80, P140, P200, P250

# Specifications

Model		PEFY-P80VMH-E-F	PEFY-P140VMH-E-F	PEFY-P200VMH-E-F	PEFY-P250VMH-E-F	
Power source		1-phase 220-240V 50Hz / 1-phase 208-230V 60Hz		3-phase 380-415V 50Hz / 3N- 380-415V 60Hz		
Cooling capacity	*1 kW	9.0	16.0	22.4	28.0	
	*1 BTU/h	30,700	54,600	76,400	95,500	
Temp. range of cooling		21°C.D.B./15.5°C.W.B. ~ 43°C.D.B./35°C.W.B. * Thermo-off (FAN-mode) automatically starts if the outdoor temperature is lower than 21°C.D.B.				
Heating capacity	*1 kW	8.5	15.1	21.2	26.5	
	*1 BTU/h	29,000	51,500	72,300	90,400	
Temp. range of heating		-10°C.D.B. ~ 20°C.D.B. * Thermo-off (FAN-mode) automatically starts if the outdoor temperature is higher than 20°C.D.B.				
Power consumption	*2 Cooling	kW	0.16 / 0.21	0.29 / 0.33	0.34 / 0.42	0.39 / 0.50
	*2 Heating	kW	0.16 / 0.21	0.29 / 0.33	0.34 / 0.42	0.39 / 0.50
Current	*2 Cooling	A	0.67 / 0.91	1.24 / 1.48	0.58 / 0.74	0.68 / 0.86
	*2 Heating	A	0.67 / 0.91	1.24 / 1.48	0.58 / 0.74	0.68 / 0.86
External finish		Galvanized				
Dimension H x W x D		mm (in.)	380 x 1,000 x 900 (15 x 39-3/8 x 35-7/16)	380 x 1,200 x 900 (15 x 47-1/4 x 35-7/16)	470 x 1,250 x 1120 (18-9/16 x 49-1/4 x 44-1/8)	
Net weight		kg (lbs)	50 (111)	67 (148)	100 (221)	
Heat exchanger		Cross fin (Aluminum plate fin and copper tube)				
Fan	Type x Quantity	Sirocco fan x 1		Sirocco fan x 2		
	Airflow rate	m <sup>3</sup> /min	9.0	18.0	28	35
		L/s	150	300	467	583
		cfm	318	636	989	1,236
External static pressure *3	208V	Pa	<35> - 85 - <170>	<35> - 85 - <170>	-	-
	220V	Pa	<40> - 115 - <190>	<50> - 115 - <190>	-	-
	230V	Pa	<50> - 130 - <210>	<60> - 130 - <220>	-	-
	240V	Pa	<80> - 170 - <220>	<100> - 170 - <240>	-	-
	380V	Pa	-	-	<140> / 200	<110> / 190
	400V	Pa	-	-	<150> / 210	<120> / 200
	415V	Pa	-	-	<160> / 220	<130> / 210
Motor	Type	1-phase induction motor		3-phase induction motor		
	Output	kW	0.09 (220V, 115Pa)	0.14 (220V, 115Pa)	0.20 (415V, 220Pa)	0.23 (415V, 210Pa)
Air filter (option)		Synthetic fiber unwoven cloth filter (long life)				
Refrigerant pipe diameter	Gas	mm (in.)	ø15.88 (ø5/8) Flare		ø19.05 (ø3/4) Brazed	ø22.2 (ø7/8) Brazed
	Liquid	mm (in.)	ø9.52 (ø3/8) Flare		ø9.52 (ø3/8) Brazed	
Field drain pipe diameter		mm (in.)	O.D.32 (1-1/4)		O.D.32 (1-1/4)	
Sound pressure level (measured in anechoic room)*2 *4	208, 220V	dB<A>	38	38	-	-
	230, 240V	dB<A>	43	43	-	-
	380V	dB<A>	-	-	42	44
	400V	dB<A>	-	-	43	45
	415V	dB<A>	-	-	44	46

## Notes:

\*1 Cooling/Heating capacity indicates the maximum value at operation under the following condition.

	Indoor	Outdoor	Pipe length	Level difference
Cooling	33°CDB/28°CWB (91°FDB/82°FWB)	33°CDB (91°FDB)	7.5 m (24-9/16 ft)	0m (0ft.)
Heating	0°CDB/-2.9°CWB (32°FDB/27°FWB)	0°CDB/-2.9°CWB (32°FDB/27°FWB)	7.5 m (24-9/16 ft)	0m (0ft.)

\*2 The values are measured at the factory setting of external static pressure.

The figure of Electrical characteristic indicates at 240V 50Hz/230V 60Hz (PEFY-P80, 140VMH-E-F type), at 50Hz/60Hz (PEFY-P200, 250VMH-E-F type).

\*3 The factory setting of external static pressure is shown without < >.

Refer to "Fan characteristics curves", according to the external static pressure, in DATA BOOK for the usable range of air flow rate.

\*4 Measured in anechoic room with a 1 m air inlet duct and 2 m air outlet duct attached to the unit and 1.5 m below the unit.

- Depending on the air conditioning load, outside temperature, and due to the activation of protection functions, the outlet air temperature may swing. Note that untreated outside air may be delivered directly into the room upon the activation of protection functions.
- The maximum connectable indoor units to 1 outdoor unit are 110% (100% in case of heating below -5°C).
- When fresh air intake type indoor units connect to an outdoor unit together with other types of indoor unit, the total capacity of fresh air intake type indoor units needs to be 30% or less of the connected outdoor unit capacity.
- Either a remote controller (sold separately) or a remote sensor (sold separately) must be installed to monitor the room temperature.
- The AUTO mode on the local remote controller is available only when fresh air intake type indoor unit is connected to the R2 or WR2 series of outdoor unit.
- The system changeover function is available only when all the connected indoor units are fresh air intake type indoor units.
- The fan temporary stops during defrost.
- Dry mode is not available.
- In any case, the air flow rate should be kept lower than 110% of the above chart. Please see "Fan characteristics curves" in DATA BOOK for the details.
- When this unit is used as sole A/C system, be careful about the dew in air outlet grilles in cooling mode.
- Un-conditioned outdoor air such as humid air or cold air blows to the indoor during thermo off operation.
- Please be careful when positioning indoor unit air outlet grilles, ie take the necessary precautions for cold air, and also insulate rooms for dew condensation prevention as required.
- Air filter must be installed in the air intake side. The filter should be attached where easy maintenance is possible in case of usage of field supply filters.
- Fresh air intake type indoor units cannot be connected to PUMY series, except for PUMY-SP125/140V(Y)KM2, PUMY-CP125/140VKM2, PUMY-CP125/140/200/225YKM2, PUMY-P200/225YKM3.
- Fresh air intake type indoor unit and PUMY have to be one to one connection. Fresh air intake type unit cannot be connected to an outdoor unit together with PWFY series.



## Low noise type

### PEFY-P VMR-E-L/R

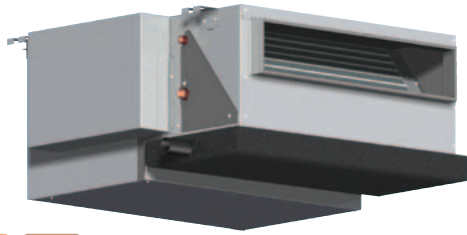

\* The picture represents -L type. For -R type, the control box comes to the right side when looked at from the front.



### Low-noise operation for a quiet indoor environment

Low noise design: Minimum of 20 dB when air flow rate is low and maximum of 35 dB when air flow rate is high.

\* Noise values measured on a rear-inlet model in an anechoic room. (The noise value is higher in cases where the bottom inlet is used.)

### Flexibly application in symmetrically arranged rooms

Models are available with refrigerant/drain piping and control box on either the right or left sides. They can be flexibly applied to symmetrically arranged hotel rooms.

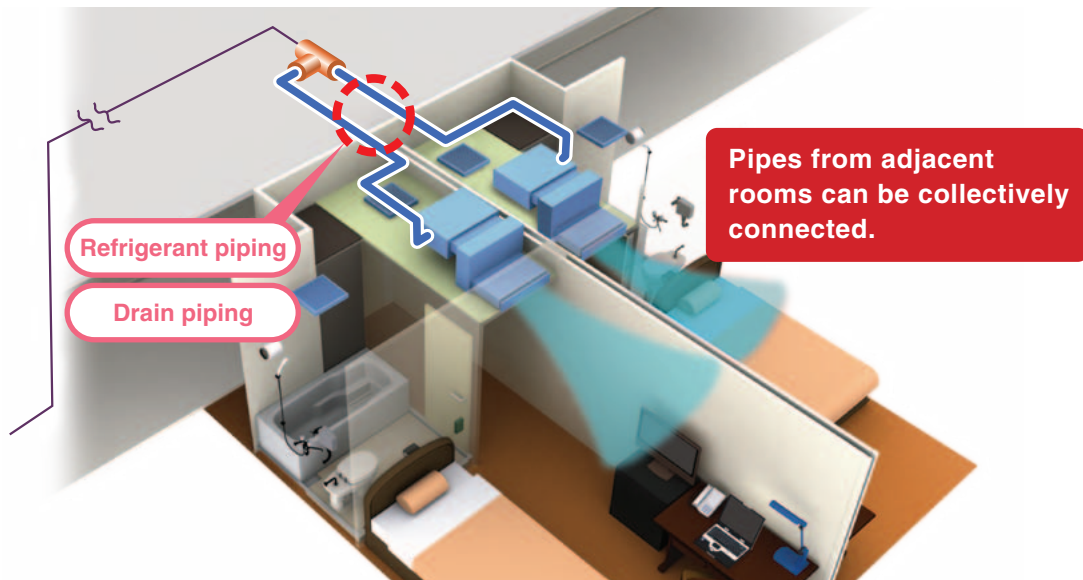

### Easy Maintenance

The fan case has no screws and can be easily removed, meaning the fan is easy to maintain. The air filter can be removed from the side or rear of the body.

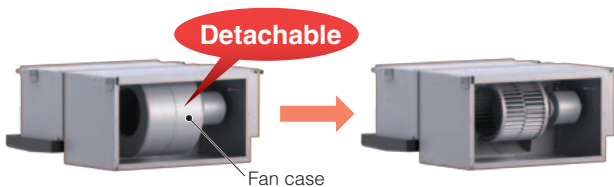

### Air inlet direction can easily be changed

The rear or bottom air inlet can be selected according to the room's layout.

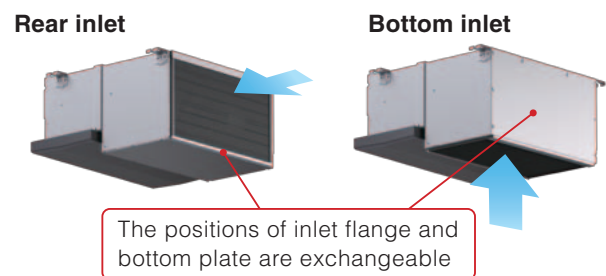

By exchanging the closing board and air filter, rear inlet and bottom inlet can be changed. (At factory shipment: Rear inlet)

\* The units with bottom inlet make more noise than those with rear inlet. It is recommended to choose the type of "with rear inlet" for the rooms that should be quiet such as bedrooms.



# Specifications

Model		PEFY-P20VMR-E-L	PEFY-P25VMR-E-L	PEFY-P32VMR-E-L
Power source		1-phase 220-230-240V 50Hz/1-phase 220-230V 60Hz		
Cooling capacity	*1 kW	2.2	2.8	3.6
	*1 BTU/h	7,500	9,600	12,300
Heating capacity	*1 kW	2.5	3.2	4.0
	*1 BTU/h	8,500	10,900	13,600
Power consumption	Cooling kW	0.06/0.06	0.06/0.06	0.07/0.08
	Heating kW	0.06/0.06	0.06/0.06	0.07/0.08
Current	Cooling A	0.29/0.29	0.29/0.29	0.34/0.38
	Heating A	0.29/0.29	0.29/0.29	0.34/0.38
External finish		Galvanized		
Dimension	Rear inlet mm (in.)	292 x 640 x 580 (11-1/2 x 25-1/4 x 22-7/8)		
	Bottom inlet mm (in.)	300 x 640 x 570 (11-7/8 x 25-1/4 x 22-1/2)		
Net weight		kg (lbs.) 18 (40)		
Heat exchanger		Cross fin (Aluminum fin and copper tube)		
Fan	Type x Quantity		Sirocco fan x 1	
	Airflow rate (Lo-Mid-Hi)	m <sup>3</sup> /min	4.8-5.8-7.9	4.8-5.8-9.3
		L/s	80-97-132	80-97-155
		cfm	170-205-279	170-205-328
External static pressure	*2 Pa	5		
Motor	Type	1-phase induction motor		
	Output kW	0.018		0.023
Air filter		PP Honeycomb fabric (washable)		
Refrigerant pipe diameter	Gas mm (in.)	ø12.7 (ø1/2) Brazed		
	Liquid mm (in.)	ø6.35 (ø1/4) Brazed		
Field drain pipe diameter		mm (in.) O.D. 26 (1)		
Sound pressure level (Lo-Mid-Hi)	*3 220V dB (A)	20-25-30		20-25-33
	230V dB (A)	21-26-32		21-26-35
	240V dB (A)	22-27-30		22-27-33

Model		PEFY-P20VMR-E-R	PEFY-P25VMR-E-R	PEFY-P32VMR-E-R
Power source		1-phase 220-230-240V 50Hz/1-phase 220-230V 60Hz		
Cooling capacity	*1 kW	2.2	2.8	3.6
	*1 BTU/h	7,500	9,600	12,300
Heating capacity	*1 kW	2.5	3.2	4.0
	*1 BTU/h	8,500	10,900	13,600
Power consumption	Cooling kW	0.06/0.06	0.06/0.06	0.07/0.08
	Heating kW	0.06/0.06	0.06/0.06	0.07/0.08
Current	Cooling A	0.29/0.29	0.29/0.29	0.34/0.38
	Heating A	0.29/0.29	0.29/0.29	0.34/0.38
External finish		Galvanized		
Dimension	Rear inlet mm (in.)	292 x 640 x 580 (11-1/2 x 25-1/4 x 22-7/8)		
	Bottom inlet mm (in.)	300 x 640 x 570 (11-7/8 x 25-1/4 x 22-1/2)		
Net weight		kg (lbs.) 18 (40)		
Heat exchanger		Cross fin (Aluminum fin and copper tube)		
Fan	Type x Quantity		Sirocco fan x 1	
	Airflow rate (Lo-Mid-Hi)	m <sup>3</sup> /min	4.8-5.8-7.9	4.8-5.8-9.3
		L/s	80-97-132	80-97-155
		cfm	170-205-279	170-205-328
External static pressure	*2 Pa	5		
Motor	Type	1-phase induction motor		
	Output kW	0.018		0.023
Air filter		PP Honeycomb fabric (washable)		
Refrigerant pipe diameter	Gas mm (in.)	ø12.7 (ø1/2) Brazed		
	Liquid mm (in.)	ø6.35 (ø1/4) Brazed		
Field drain pipe diameter		mm (in.) O.D. 26 (1)		
Sound pressure level (Lo-Mid-Hi)	*3 220V dB (A)	20-25-30		20-25-33
	230V dB (A)	21-26-32		21-26-35
	240V dB (A)	22-27-30		22-27-33

## Notes:

\*1 Cooling/Heating capacity indicates the maximum value at operation under the following condition.

Cooling : Indoor 27°C(81°F)DB/19°C(66°F)WB, Outdoor 35°C(95°F)DB  
 Heating : Indoor 20°C(68°F)DB, Outdoor 7°C(45°F)DB/6°C(43°F)WB

\*2 The external static pressure is set to 5Pa (at 220V, 230V, 240V).

\*3 Measured in anechoic room. Sound pressure levels of the unit with a rear air inlet. (Sound pressure levels are higher than the unit with a bottom air inlet.)

\* If quietness is required, installation of a crank-shaped duct is recommended. Please refer to the installation pattern below for the duct system design.

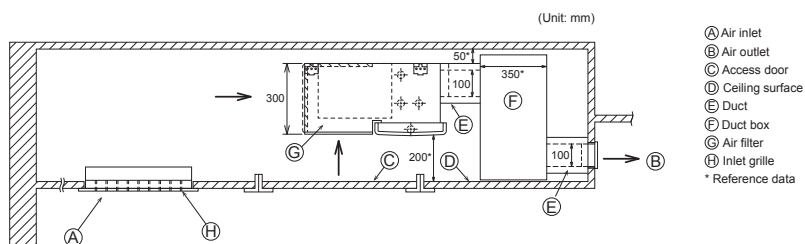

# Ceiling suspended type

## PCFY-P VKM-E



### Easy installation

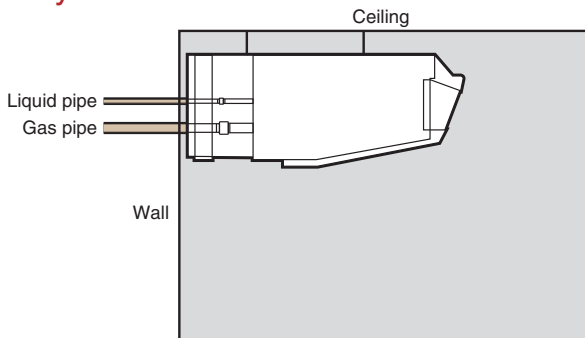

The ceiling suspended cassette can easily be installed without requiring duct work, even if the ceiling does not have sufficient space.

### Drain pump is available for all models

The optional drain pump allows the drain connection to be raised as high as 600mm [23-5/8 in.], expanding flexibility in choosing the unit's location.

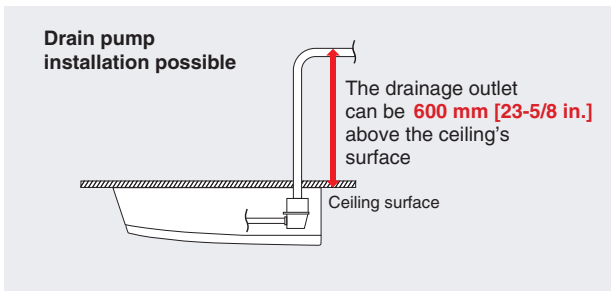

### Equipped with automatic air-speed adjustment

In addition to the conventional 4-speed settings, units are now equipped with an automatic air-speed adjustment mode. This setting automatically adjusts the air-speed to conditions that match the room environment. At the start of heating/cooling operation, the airflow is set to high-speed to quickly heat/cool the room. When the room temperature reaches the desired setting, the airflow speed is decreased automatically for stable comfortable heating/cooling operation.



230 mm [9-1/16 in.] high unit is designed in consideration of interior design coordination

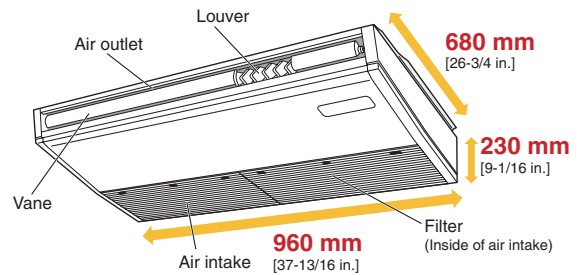

Sleek and slim with stylishly curved lines, the PCFY-Series is designed to blend into interior.

### Auto Vane Control

Outlet vanes can be moved up and down using the remote controller. This improved airflow control feature solves the problem of drafts.

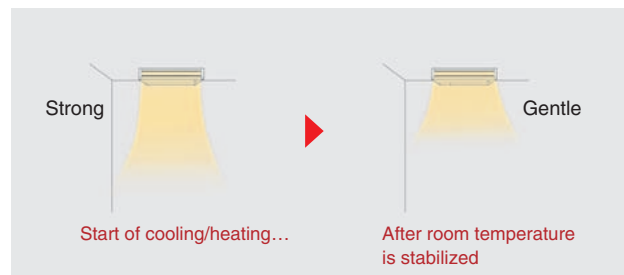
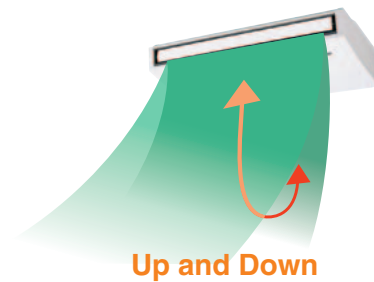

### Optional Parts

Description	Model	Applicable capacity
Drain pump kit	PAC-SH83DM-E	P40
	PAC-SH84DM-E	P63, 100, 125
High efficiency filter	PAC-SH88KF-E	P40
	PAC-SH89KF-E	P63
Wireless remote controller kit	PAC-SH90KF-E	P100, 125
	PAR-SL94B-E	P40, 63, 100, 125
Anti-allergy enzyme filter	PAC-SK48KF-E	P40
	PAC-SK49KF-E	P63
	PAC-SK50KF-E	P100, 125

## Specifications

Model		PCFY-P40VKM-E	PCFY-P63VKM-E	PCFY-P100VKM-E	PCFY-P125VKM-E
Power source		1-phase 220-240V 50Hz/1-phase 220V 60Hz			
Cooling capacity	*1 kW	4.5	7.1	11.2	14.0
	*1 BTU/h	15,400	24,200	38,200	47,800
Heating capacity	*1 kW	5.0	8.0	12.5	16.0
	*1 BTU/h	17,100	27,300	42,700	54,600
Power consumption	Cooling kW	0.04	0.05	0.09	0.11
	Heating kW	0.04	0.05	0.09	0.11
Current	Cooling A	0.28	0.33	0.65	0.76
	Heating A	0.28	0.33	0.65	0.76
External finish (Munsell No.)		6.4Y 8.9/ 0.4			
Dimension H x W x D		mm	230 x 960 x 680	230 x 1,280 x 680	230 x 1,600 x 680
		in.	9-1/16 x 37-13/16 x 26-3/4	9-1/16 x 50-3/8 x 26-3/4	9-1/16 x 63 x 26-3/4
Net weight		kg (lbs.)	24 (53)	32 (71)	36 (79)
Heat exchanger		Cross fin (Aluminum fin and copper tube)			
Fan	Type x Quantity		Sirocco fan x 2	Sirocco fan x 3	Sirocco fan x 4
	Airflow rate (Lo-Mid2-Mid1-Hi)	*2 m <sup>3</sup> /min	10-11-12-13	14-15-16-18	21-24-26-28
		L/s	167-183-200-217	233-250-267-300	350-400-433-467
		cfm	353-388-424-459	494-530-565-636	742-847-918-989
External static pressure		Pa			
Motor		DC motor			
Type		Output			
Output		kW	0.090	0.095	0.160
Air filter		PP Honeycomb (long life)			
Refrigerant pipe diameter	Gas (Flare)	mm (in.)	ø12.7 (ø1/2)	ø15.88 (ø5/8)	
	Liquid (Flare)	mm (in.)	ø6.35 (ø1/4)	ø9.52 (ø3/8)	
Field drain pipe diameter		mm (in.)	O.D. 26 (1)		
Sound pressure level (Lo-Mid2-Mid1-Hi)		*2 *3 dB (A)	29-32-34-36	31-33-35-37	36-38-41-43
					36-39-42-44

### Notes:

- \*1 Cooling/Heating capacity indicates the maximum value at operation under the following condition.  
Cooling Indoor : 27°C(80.6°F)DB/19°C(66.2°F)WB, Outdoor 35°C(95°F)DB  
Heating Indoor : 20°C(68°F)DB, Outdoor 7°C(44.6°F)DB/6°C(42.8°F)WB
- \*2 Airflow rate/Sound pressure level are shown in (low-middle 2-middle 1-high).
- \*3 It is measured in anechoic room.

# Wall-mounted type

## PKFY-P VLM-E PKFY-P VKM-E



PKFY-P VLM (P15~P32)



PKFY-P VLM (P40/P50)



PKFY-P VKM (P63/P100)



### New design that matches the room's interior (VLM model)

P15~P25



PKFY-P VBM

P32~P50



PKFY-P VHM

Conventional model



P15~P32



P40/P50



PKFY-P VLM

New model

A sharp and simple form that combines beauty and function. The simple square design harmonizes beautifully with the straight lines created by the intersection of the walls, floor and ceiling. Also adopted a new white body color. It will make your life and space beautiful and comfortable without disturbing the atmosphere of the room.

### Low noise

The noise level has been reduced compared to the conventional model (PKFY-P VBM/VHM) by improving the unit structure such as the line flow fan.

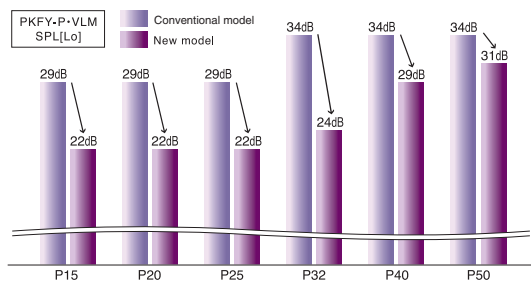

\* Measurement condition (Fan speed: Low)

\* It is measured in anechoic room.

### Improved Airflow control

Fan speed and Vane control

The new model (VLM) can set the fan speed to 4 steps and auto mode. Also, the vane angle can be set to 5 steps. This has enabled air conditioning to be tailored to your taste.

		Conventional		New PKFY-P**VLM-E
		PKFY-P**VBM	PKFY-P**VHM	
Fan Speed	Fan Speed	4 speeds	3 speeds + AUTO	4 speeds + AUTO
	Vane Control	Vane Angle	4 steps	5 steps
	Swing mode	-	✓	✓

### Drain pump option

The optional drain pump allows the drain connection to be raised as high as 850mm (P15-50), 800mm (P63/100), allowing more flexible in piping layout design.

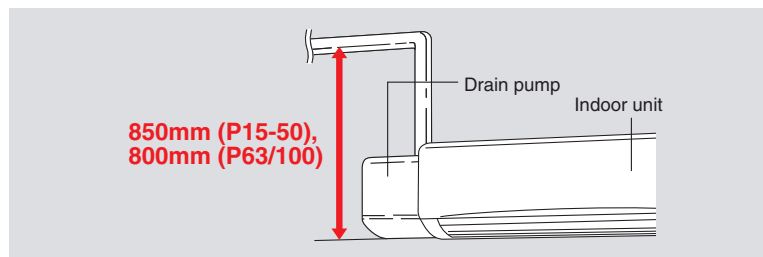

### Optional Parts

Description	Model	Applicable capacity
External LEV Box	PAC-SG95LE-E	P15, 20, 25, 32, 40, 50, 63
Drain pump kit	PAC-SK01DM-E	P15, 20, 25, 32, 40, 50
	PAC-SH94DM-E	P63, 100
Plasma quad connect	MAC-100FT-E	P15, 20, 25, 32, 40, 50, 63, 100

# Specifications

Model		PKFY-P15VLM-E	PKFY-P20VLM-E	PKFY-P25VLM-E	PKFY-P32VLM-E	PKFY-P40VLM-E	PKFY-P50VLM-E	
Power source		1-phase 220-240 V 50 Hz, 1-phase 220-230 V 60Hz						
Cooling capacity (Nominal)	*1 kW	1.7	2.2	2.8	3.6	4.5	5.6	
	*1 BTU/h	5,800	7,500	9,600	12,300	15,400	19,100	
	Power input kW	0.02	0.02	0.03	0.04	0.04	0.05	
Heating capacity (Nominal)	Current input A	0.20	0.20	0.25	0.35	0.35	0.45	
	*2 kW	1.9	2.5	3.2	4.0	5.0	6.3	
	*2 BTU/h	6,500	8,500	10,900	13,600	17,100	21,500	
Power input (220V)	kW	0.01	0.01	0.02	0.03	0.03	0.04	
	Current input A	0.15	0.15	0.20	0.30	0.30	0.40	
External finish (Munsell No.)		Plastic (0.7PB 9.2/0.4)						
External dimension		mm 299 x 773 x 237				299 x 898 x 237		
H x W x D		in. 11-25/32 x 30-7/16 x 9-11/32				11-25/32 x 35-3/8 x 9-11/32		
Net weight		kg (lbs.) 11 (25)				13 (29)		
Heat exchanger		Cross fin (Aluminum fin and copper tube)						
Fan	Type x Quantity		Line flow fan x 1					
	External static press Pa (mmH <sub>2</sub> O)		0 (0)					
	Motor type		DC motor					
	Motor output kW		0.03					
	Driving mechanism		Direct driven					
	Airflow rate (Lo-Mid2-Mid1-Hi)		m <sup>3</sup> /min 4.0-4.2-4.4-4.7	4.0-4.4-4.9-5.4	4.0-4.6-5.4-6.7	4.3-5.4-6.9-8.4	6.3-7.4-8.6-10.0	6.8-8.3-10.2-12.4
			L/s 67-70-73-78	67-73-82-90	67-77-90-112	72-90-115-140	105-123-143-167	113-138-170-207
		cfm 141-148-155-166	141-155-173-191	141-162-191-237	152-191-244-297	222-261-304-353	240-293-360-438	
Noise level (measured in anechoic room)		dB (A) 22-24-26-28		22-26-29-31	22-27-31-35	24-31-37-41	29-34-37-40	
Insulation material		Polyethylene sheet						
Air filter		PP honeycomb						
Protection device		Fuse						
Refrigerant control device		LEV						
Refrigerant piping diameter	Liquid (Flare) mm (in.)	ø6.35 (ø1/4)						
	Gas (Flare) mm (in.)	ø12.7 (ø1/2)						
Field drain pipe diameter		mm (in.) I.D.16 (5/8)						
Optional parts	DRAIN PUMP KIT		PAC-SK01DM-E					
	EXTERNAL LEV BOX		PAC-SG95LE-E					

## Notes:

- \*1 Nominal cooling conditions (subject to JIS B8615-1) Indoor : 27°C.D.B./19°C.W.B. (81°F.D.B./66°F.W.B.), Outdoor 35°C.D.B. (95°F.D.B.) Pipe length : 7.5 m (24-9/16 ft.), Level difference : 0 m (0 ft.)
- \*2 Nominal heating conditions (subject to JIS B8615-1) Indoor : 20°C.D.B. (68°F.D.B.), Outdoor 7°C.D.B./6°C.W.B. (45°F.D.B./43°F.W.B.) Pipe length : 7.5 m (24-9/16 ft.), Level difference : 0 m (0 ft.)

Model		PKFY-P63VKM-E	PKFY-P100VKM-E	
Power source		1-phase 220-240V 50Hz, 1-phase 220V 60Hz		
Cooling capacity (Nominal)	*1 kW	7.1	11.2	
	*1 BTU/h	24,200	38,200	
	Power input kW	0.05	0.08	
Heating capacity (Nominal)	Current input A	0.37	0.58	
	*2 kW	8.0	12.5	
	*2 BTU/h	27,300	42,600	
Power input (220V)	kW	0.04	0.07	
	Current input A	0.30	0.51	
External finish (Munsell No.)		Plastic, MUNSELL (1.0Y 9.2/0.2)		
External dimension		mm 365x1170x295		
H x W x D		in. 14-3/8 x 46-1/16 x 11-5/8		
Net weight		kg (lbs.) 21(46)		
Heat exchanger		Cross fin (Aluminum fin and copper tube)		
Fan	Type x Quantity		Line flow fan x 1	
	External static press Pa (mmH <sub>2</sub> O)		0 (0)	
	Motor type		DC motor	
	Motor output kW		0.056	
	Driving mechanism		Direct-drive	
	Airflow rate (Low-High)		m <sup>3</sup> /min 16-20	20-26
			L/s 267-333	333-433
		cfm 565-706	706-918	
Sound pressure level (measured in anechoic room)		dB (A) 39-45		
Insulation material		Polyethylene sheet		
Air filter		PP honeycomb		
Protection device		Fuse		
Refrigerant control device		LEV		
Refrigerant piping diameter	Liquid (Flare) mm (in.)	ø9.52 (ø3/8)		
	Gas (Flare) mm (in.)	ø15.88 (ø5/8)		
Field drain pipe diameter		mm (in.) I.D.16 (5/8)		
Optional parts	DRAIN PUMP KIT		PAC-SH94DM-E	
	EXTERNAL LEV BOX		PAC-SG95LE-E	

## Notes:

- \*1 Nominal cooling conditions (subject to JIS B8615-1) Indoor : 27°C.D.B./19°C.W.B. (81°F.D.B./66°F.W.B.), Outdoor 35°C.D.B. (95°F.D.B.) Pipe length : 7.5 m (24-9/16 ft.), Level difference : 0 m (0 ft.)
- \*2 Nominal heating conditions (subject to JIS B8615-1) Indoor : 20°C.D.B. (68°F.D.B.), Outdoor 7°C.D.B./6°C.W.B. (45°F.D.B./43°F.W.B.) Pipe length : 7.5 m (24-9/16 ft.), Level difference : 0 m (0 ft.)



## Floor standing exposed type

### PFFY-P VKM-E2



#### Sophisticated Design

An innovative floor-standing air-conditioner from Mitsubishi Electric. A pleasing mix of streamlined form and diversified function. Engineered to keep room walls free, provide comfortable cooling in summer, and toasty heating in the winter.

The "Glossy Pure White" color ensures a deluxe look, a perfect match for any room. Both upper and lower air outlets remain closed when switched off, a smart and striking image.

A superb new air-conditioner from Mitsubishi Electric, providing a handsome fit for your own distinctive interior.

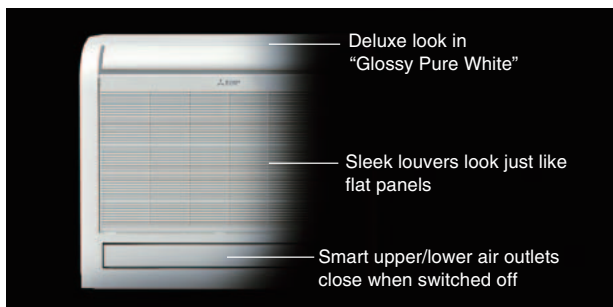

#### Slim yet Mighty

The unit's body is slim and trim, highlighting its compact essence. An ideal size for living rooms, bedrooms, and more.

The removable and washable front panel makes cleaning a snap. Easy, regular cleaning helps your air-conditioner stay beautiful while maintaining its energy-efficient operation.

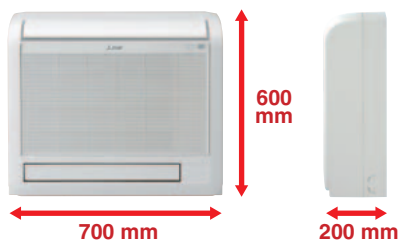

#### Optimum Air Distribution

Comfy room temperatures are accomplished through optimum, powerful and efficient air distribution through the upper and lower air outlets.

The upper vane angle is remote controllable, with 5 air flow direction levels (+Swing and Auto modes) and 4 wind power levels (+Auto mode).

By setting the vane angle almost vertical, bothersome direct wind can be avoided for increased comfort.

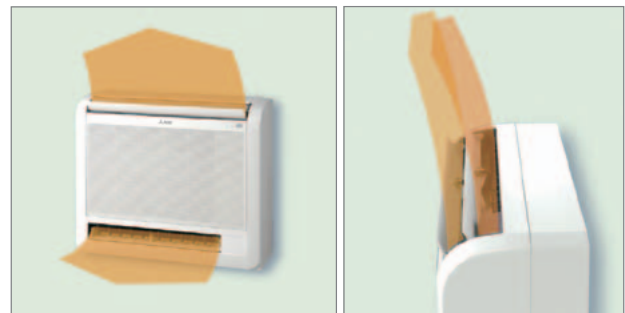

The air from both the upper and lower air outlets is optimally controlled and distributed evenly to every corner of the room. In heating mode, the warm air is smartly controlled to stay at the floor level: Say goodbye to chilly feet!

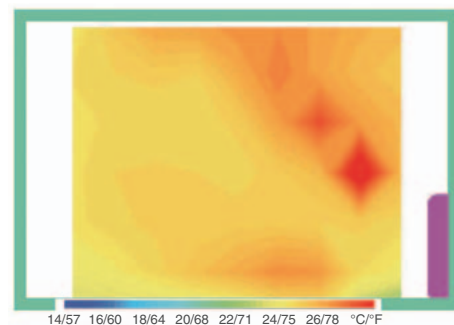

## Specifications

Model			PFFY-P20VKM-E2	PFFY-P25VKM-E2	PFFY-P32VKM-E2	PFFY-P40VKM-E2	
Power source			1-phase 220-240V 50Hz				
Cooling capacity	*1	kW	2.2	2.8	3.6	4.5	
		BTU/h	7,500	9,600	12,300	15,400	
Heating capacity	*1	kW	2.5	3.2	4.0	5.0	
		BTU/h	8,500	10,900	13,600	17,100	
Power consumption	Cooling	kW	0.025	0.025	0.025	0.028	
	Heating	kW	0.025	0.025	0.025	0.028	
Current	Cooling	A	0.20	0.20	0.20	0.24	
	Heating	A	0.20	0.20	0.20	0.24	
External finish			Plastic (Pure white)				
Dimension H x W x D		mm	600 x 700 x 200				
		in.	23-5/8 x 27-9/16 x 7-7/8				
Net weight		kg (lbs.)	15 (34)				
Heat exchanger			Cross fin (Aluminium plate fin and copper tube)				
Fan			Line flow fan x 2				
Airflow rate (Lo-Mid-Hi-SHi)		*2	m <sup>3</sup> /min	5.9-6.8-7.6-8.7	6.1-7.0-8.0-9.1	6.1-7.0-8.0-9.1	8.0-9.0-9.5-10.7
			Pa	0			
Motor		Type	DC motor				
		Output	0.03 x 2				
Air filter			PP honeycomb fabric (Catechin Filter)				
Refrigerant pipe diameter		Gas (Flare)	mm (in.)				
		Liquid (Flare)	mm (in.)				
Field drain pipe diameter		mm (in.)	I.D.16 (5/8)				
Sound pressure level (Lo-Mid-Hi-SHi)		*2	dB (A)	27-31-34-37	28-32-35-38	28-32-35-38	35-38-42-44

### Notes:

- \*1 Cooling/heating capacity indicates the maximum value at operation under the following condition.  
Cooling Indoor : 27°C(81°F)DB/19°C(66°F)WB, Outdoor : 35°C(95°F)DB  
Heating Indoor : 20°C(68°F)DB, Outdoor : 7°C(45°F)DB/6°C(43°F)WB
- \*2 Airflow rate/Sound pressure level are in (low-middle-high-shigh).
- \*3 It is measured in anechoic room.

# Floor standing exposed type

## PFFY-P VLEM-E



### Compact unit for easy perimeter air-conditioning

The compact body depth of 220 mm [8-11/16 in.] can be easily installed in a perimeter zone for effective air-conditioning.

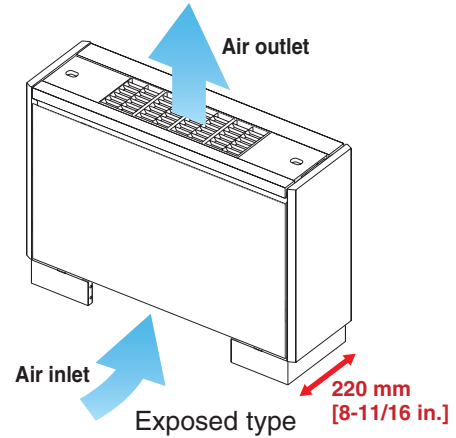

### Remote controller can be installed on the main unit

The remote controller can be embedded in the main unit, allowing temperature and air volume to be easily set.

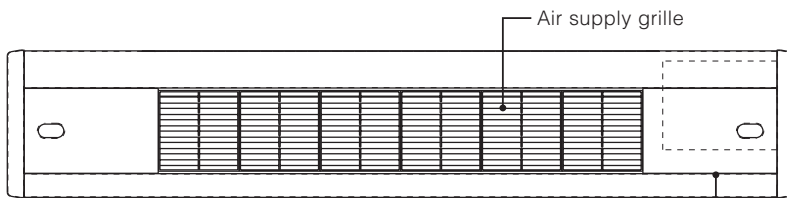

The remote controller (PAR-41MAA) can be built into the unit.  
(Program timer can not be built-in together)



PAR-41MAA

## Specifications

Model		PFFY-P20VLEM-E	PFFY-P25VLEM-E	PFFY-P32VLEM-E	PFFY-P40VLEM-E	PFFY-P50VLEM-E	PFFY-P63VLEM-E	
Power source		1-phase 220-240V 50Hz/1-phase 208-230V 60Hz						
Cooling capacity	*1 kW	2.2	2.8	3.6	4.5	5.6	7.1	
	*1 BTU/h	7,500	9,600	12,300	15,400	19,100	24,200	
Heating capacity	*1 kW	2.5	3.2	4.0	5.0	6.3	8.0	
	*1 BTU/h	8,500	10,900	13,600	17,100	21,500	27,300	
Power consumption	Cooling kW	0.04/0.06		0.06/0.07	0.065/0.075		0.1/0.11	
	Heating kW	0.04/0.06		0.06/0.07	0.065/0.075		0.085/0.09	
Current	Cooling A	0.19/0.25		0.29/0.30	0.32/0.33		0.40/0.41	
	Heating A	0.19/0.25		0.29/0.30	0.32/0.33		0.40/0.41	
External finish (Munsell No.)		Acrylic paint (5Y 8/1)						
Dimension H x W x D	mm	630 x 1,050 x 220		630 x 1,170 x 220		630 x 1,410 x 220		
	in.	24-13/16 x 41-3/8 x 8-11/16		24-13/16 x 46-1/8 x 8-11/16		24-13/16 x 55-9/16 x 8-11/16		
Net weight	kg (lbs.)	28 (62)		30 (67)	32 (71)		36 (80) 37 (82)	
Heat exchanger		Cross fin (Aluminum plate fin and copper tube)						
Fan	Type x Quantity	Sirocco fan x 1			Sirocco fan x 2			
	Airflow rate (Lo-Hi)	*2 m <sup>3</sup> /min	5.5-6.5		7.0-9.0	9.0-11.0		12.0-14.0 12.0-15.5
		L/s	92-108		117-150	150-183		200-233 200-258
		cfm	194-230		247-318	318-388		424-494 424-547
External static pressure	Pa	0						
Motor	Type	1-phase induction motor						
	Output	kW		0.015	0.018	0.030	0.035 0.050	
Air filter		PP Honeycomb fabric (washable)						
Refrigerant pipe diameter	Gas (Flare)	mm (in.)					ø12.7 (ø1/2) ø15.88 (ø5/8)	
	Liquid (Flare)	mm (in.)					ø6.35 (ø1/4) ø9.52 (ø3/8)	
Field drain pipe diameter		mm (in.)						
Sound pressure level (Lo-Hi)		*2 *3 *4 dB (A)		34-40	35-40	38-43 40-46		

### Notes:

- \*1 Cooling/Heating capacity indicates the maximum value at operation under the following condition.  
Cooling Indoor : 27°C(81°F)DB/19°C(66°F)WB, Outdoor 35°C(95°F)DB  
Heating Indoor : 20°C(68°F)DB, Outdoor 7°C(45°F)DB/6°C(43°F)WB
- \*2 Air flow rate/Sound pressure level are in (Low-High)
- \*3 Measured point : 1m x 1m, Power supply : AC240V/50Hz
  - 1dB(A) lower at AC230V/50Hz
  - 2dB(A) lower at AC220V/50Hz
  - 3dB(A) lower at 1.5m x 1.5m point
- \*4 It is measured in anechoic room.

# Floor standing concealed type

## PFFY-P VCM-E



### Reduced power consumption and noise

The structure realizes smooth airflow to reduce pressure loss in the air pathway. Additionally, the inner pipes of its heat exchanger have been downsized from  $\varnothing 9.52$  to  $\varnothing 7.0$  to contain a larger number of pipings.

The combination of the structure and components contributes to reducing power consumption and operation noise.

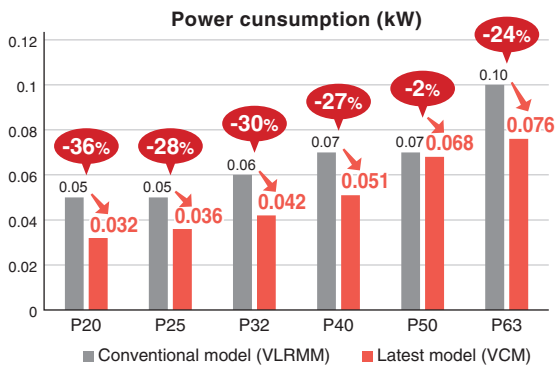

\* Measurement condition (External static pressure: 40Pa Fan speed: High)  
\* The unit consumes the same power in both cooling and heating modes.

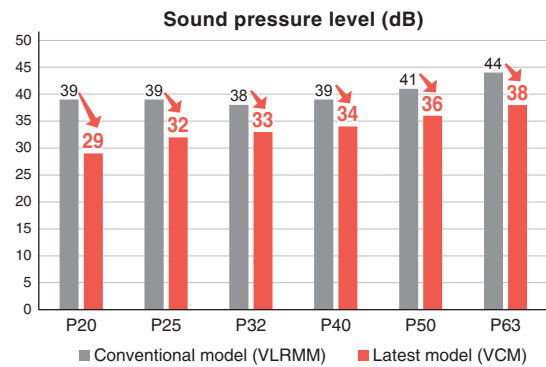

\* Measurement condition (External static pressure: 40Pa Fan speed: High)  
\* The sound pressure level in operation is measured at 1.5 m apart from the front side and bottom side of the unit in anechoic room.

### Flexible installation pattern ideal for perimeter zone air conditioning

Air inlet can be selected from two patterns, bottom suction or front suction, by changing the panel, fan guard and filter.

#### • Bottom suction\*1

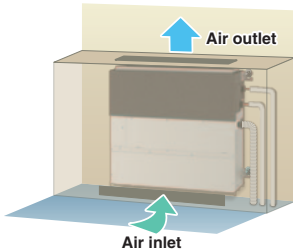

#### • Front suction\*2

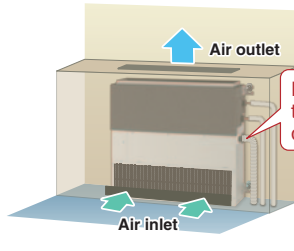

Front suction allows the unit to be placed directly on the floor.

#### • Floor standing with legs

The unit can be placed on the floor with the supplied legs attached.

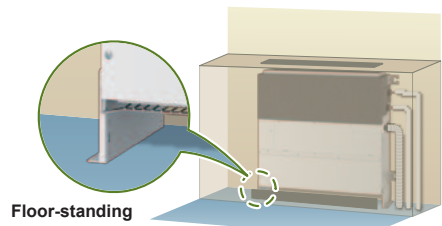

Floor-standing

\* Height of unit (with legs) is 690 mm.

\*1 Select a site where the flow of supply air is not blocked. The unit cannot be placed directly on the floor in the case of bottom suction.

\*2 Front suction makes more noise than bottom suction. Bottom suction is recommended when installing the unit in rooms that need to be quiet, such as bedrooms.

### Smaller footprint

The latest model (P32) has a 36% smaller footprint compared to the PFFY-VLRMM, owing to a redesigning of the positions of the inner components.

Conventional model (P32)

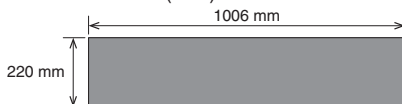

Latest model (P32)

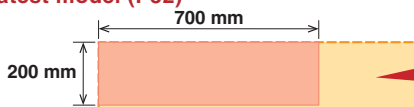

36% down

### Flexible airflow and external static pressure setting

Airflow rate and external static pressure can be selected to suit various installation conditions.

Air flow rate	Conventional	
	PFFY-P VLRM	Low-High
	PFFY-P VLRMM	Low-Mid-High
	<b>Latest</b>	
	<b>PFFY-P VCM</b>	<b>Low-Mid-High</b>

External static pressure (Pa)	Conventional	
	PFFY-P VLRM	0
	PFFY-P VLRMM	20-40-60
	<b>Latest</b>	
	<b>PFFY-P VCM</b>	<b>0-10-40-60</b>



# Specifications

Model	PFFY-P20VCM-E		PFFY-P25VCM-E		PFFY-P32VCM-E	
Power source	1-phase 220-230-240 V 50/60 Hz					
Cooling capacity (Nominal)	*1 kW	2.2	2.8	3.6		
	*1 BTU/h	7,500	9,600	12,300		
	*2 Power input kW	0.022	0.026	0.031		
	*2 Current input A	0.25	0.30	0.34		
Heating capacity (Nominal)	*3 kW	2.5	3.2	4.0		
	*3 BTU/h	8,500	10,900	13,600		
	*2 Power input kW	0.022	0.026	0.031		
	*2 Current input A	0.25	0.30	0.34		
External finish	Galvanized steel plate					
External dimension	*4 mm	615 (690) x 700 x 200	615 (690) x 700 x 200	615 (690) x 700 x 200		
H x W x D	in.	24-1/4 (27-3/16) x 27-9/16 x 7-7/8	24-1/4 (27-3/16) x 27-9/16 x 7-7/8	24-1/4 (27-3/16) x 27-9/16 x 7-7/8		
Net weight	kg (lbs)	18 (40)	18 (40)	18.5 (42)		
Heat exchanger	Cross fin (Aluminum fin and copper tube)					
FAN	Type x Quantity	Sirocco fan x 2		Sirocco fan x 2		
	*5 External static press.	<0> - 10 - <40> - <60>		<0> - 10 - <40> - <60>		
	mmH <sub>2</sub> O	<0.0> - 1.0 - <4.1> - <6.1>		<0.0> - 1.0 - <4.1> - <6.1>		
	Motor Type	DC motor		DC motor		
	Motor output kW	0.096		0.096		
	Driving mechanism	Direct-driven by motor		Direct-driven by motor		
	Air flow rate	(Low-Mid-High)		(Low-Mid-High)		
	m <sup>3</sup> /min	5.0 - 6.0 - 7.0		5.5 - 6.5 - 8.0		
	L/s	83 - 100 - 117		92 - 108 - 133		
	cfm	177 - 212 - 247		194 - 230 - 282		
Sound pressure level (measured in anechoic room)	*2 dB<A>	21-23-26		22-25-29		
Air filter	PP honeycomb fabric.					
Refrigerant	Liquid (410A)	6.35 (1/4)Braze		6.35 (1/4)Braze		
piping diameter	Gas (410A)	12.7 (1/2)Braze		12.7 (1/2)Braze		
Field drain pipe size	mm (in.)	O.D.32 (1-1/4)		O.D.32 (1-1/4)		

## Notes:

- \*1. Nominal cooling conditions  
Indoor: 27°CDB./19°CWB. (81°FDB./66°FWB.), Outdoor: 35°CDB. (95°FDB.)  
Pipe length: 7.5 m (24-9/16 ft.), Level difference: 0 m (0 ft.)
- \*2. The values are measured at the factory setting of external static pressure.
- \*3. Nominal heating conditions  
Indoor: 20°CDB. (68°FDB.), Outdoor: 7°CDB./6°CWB. (45°FDB./43°FWB.)  
Pipe length: 7.5 m (24-9/16 ft.), Level difference: 0 m (0 ft.)
- \*4. The values in ( ) show the height of unit with leg.
- \*5. The factory setting of external static pressure is shown without < > .  
Refer to "Fan characteristics curves", according to the external static pressure, in DATA BOOK for the usable range of air flow rate.
- \*Details on foundation work, duct work, insulation work, electrical wiring, power source switch, and other items shall be referred to the Installation Manual.
- \*Due to continuing improvement, above specifications may be subject to change without notice.

Model	PFFY-P40VCM-E		PFFY-P50VCM-E		PFFY-P63VCM-E	
Power source	1-phase 220-230-240 V 50/60 Hz					
Cooling capacity (Nominal)	*1 kW	4.5	5.6	7.1		
	*1 BTU/h	15,400	19,100	24,200		
	*2 Power input kW	0.038	0.052	0.058		
	*2 Current input A	0.38	0.50	0.49		
Heating capacity (Nominal)	*3 kW	5.0	6.3	8.0		
	*3 BTU/h	17,100	21,500	27,300		
	*2 Power input kW	0.038	0.052	0.058		
	*2 Current input A	0.38	0.50	0.49		
External finish	Galvanized steel plate					
External dimension	*4 mm	615 (690) x 900 x 200	615 (690) x 900 x 200	615 (690) x 1,100 x 200		
H x W x D	in.	24-1/4 (27-3/16) x 35-7/16 x 7-7/8	24-1/4 (27-3/16) x 35-7/16 x 7-7/8	24-1/4 (27-3/16) x 43-5/16 x 7-7/8		
Net weight	kg (lbs)	22.5 (51)	22.5 (51)	25.5 (58)		
Heat exchanger	Cross fin (Aluminum fin and copper tube)					
FAN	Type x Quantity	Sirocco fan x 3		Sirocco fan x 3		
	*5 External static press.	<0> - 10 - <40> - <60>		<0> - 10 - <40> - <60>		
	mmH <sub>2</sub> O	<0.0> - 1.0 - <4.1> - <6.1>		<0.0> - 1.0 - <4.1> - <6.1>		
	Motor Type	DC motor		DC motor		
	Motor output kW	0.096		0.096		
	Driving mechanism	Direct-driven by motor		Direct-driven by motor		
	Air flow rate	(Low-Mid-High)		(Low-Mid-High)		
	m <sup>3</sup> /min	8.0 - 9.5 - 11.0		10.0 - 11.5 - 13.5		
	L/s	133 - 158 - 183		167 - 192 - 225		
	cfm	282 - 335 - 388		353 - 406 - 477		
Sound pressure level (measured in anechoic room)	*2 dB<A>	25-27-30		28-31-34		
Air filter	PP honeycomb fabric.					
Refrigerant	Liquid (410A)	6.35 (1/4)Braze		9.52 (3/8)Braze		
piping diameter	Gas (410A)	12.7 (1/2)Braze		15.88 (5/8)Braze		
Field drain pipe size	mm (in.)	O.D.32 (1-1/4)		O.D.32 (1-1/4)		

## Notes:

- \*1. Nominal cooling conditions  
Indoor: 27°CDB./19°CWB. (81°FDB./66°FWB.), Outdoor: 35°CDB. (95°FDB.)  
Pipe length: 7.5 m (24-9/16 ft.), Level difference: 0 m (0 ft.)
- \*2. The values are measured at the factory setting of external static pressure.
- \*3. Nominal heating conditions  
Indoor: 20°CDB. (68°FDB.), Outdoor: 7°CDB./6°CWB. (45°FDB./43°FWB.)  
Pipe length: 7.5 m (24-9/16 ft.), Level difference: 0 m (0 ft.)
- \*4. The values in ( ) show the height of unit with leg.
- \*5. The factory setting of external static pressure is shown without < > .  
Refer to "Fan characteristics curves", according to the external static pressure, in DATA BOOK for the usable range of air flow rate.
- \*Details on foundation work, duct work, insulation work, electrical wiring, power source switch, and other items shall be referred to the Installation Manual.
- \*Due to continuing improvement, above specifications may be subject to change without notice.

# Floor standing exposed type

## PFFY-P YM-E PFFY-P YMH-E



### Reduces installation and maintenance time

This series is a floor-standing, large capacity, indoor unit, which reduces the piping and installation burdens, and makes maintenance easy.

### Increased adaptation to local needs

In addition to the standard duct blowing, both plenum blowing and rear suction are optionally selectable.

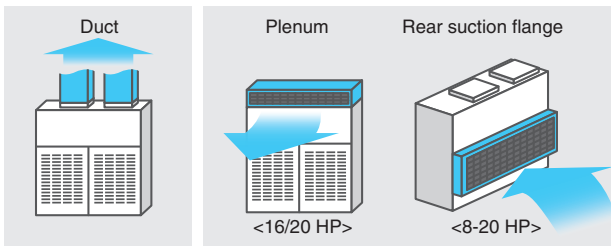

### Pulley belt option

This option supports the use of wider ranges of airflow rates and static pressures to suit a greater variety of needs.

### Both large-scale and individual air conditioning can be performed

When this model is used in a large space and CITY MULTI indoor units are used in individual rooms, one outdoor unit can control the air conditioners in these rooms of various sizes.

#### Installation example

Example: Hotel

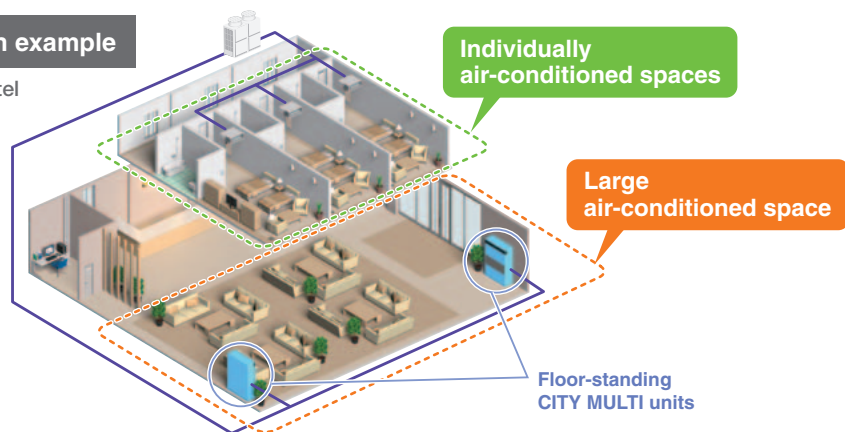

Easy to install and can cover large spaces.

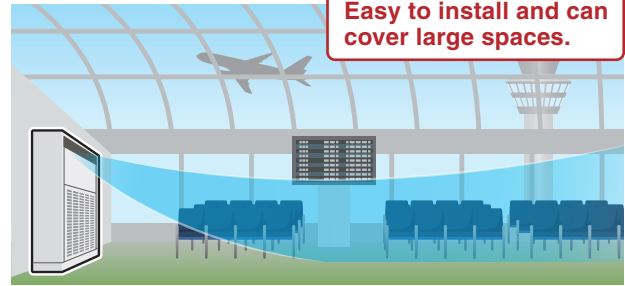

### Wide ranges of airflow rate and static pressure options are available to suit a greater variety of needs

		Air flow rate (m <sup>3</sup> /min [ft. <sup>3</sup> /min])		Static pressure (Pa)
		High, 50/60 Hz		
PFFY-P200YM-E	8 HP	65.0/69.0 [2300/2430]		0
PFFY-P250YM-E	10 HP	77.0/72.0 [2720/2540]		0
PFFY-P200YMH-E*	8 HP	65.0 [2300]		180/200
PFFY-P250YMH-E*	10 HP	72.0 [2540]		180/210
PFFY-P400YM-E	16 HP	150.0 [5300]		210/390
PFFY-P500YM-E	20 HP	200.0 [7060]		290/510

\*High static pressure model

### Multiple units can be connected to one outdoor unit

Multiple units of this model can be connected to one outdoor unit. Air can be spread throughout a large room.

### Optional Parts

Description	Model	Applicable capacity
OA duct flange	PAC-ODF10DF-E	P200, 250
	PAC-ODF20DF-E	P400, 500
Plenum	PAC-PL-E20PL-E1	P400, 500

# Specifications

Model		PFFY-P200YM-E	PFFY-P250YM-E	PFFY-P200YMH-E	PFFY-P250YMH-E	PFFY-P400YM-E	PFFY-P500YM-E	
Power source		3-phase 4-wire 380-400-415 V 50/60 Hz						
Cooling capacity (Nominal)	*1 kW	22.4	28.0	22.4	28.0	45.0	56.0	
	*1 BTU/h	76,400	95,500	76,400	95,500	153,500	191,100	
*2	Power input kW	0.490/0.680	1.05/1.26	1.00/1.41	1.31/1.41	2.86/3.79	3.94/5.30	
	Current input (380-400-415 V) A	0.97-0.98-0.99/ 1.24-1.23-1.22	1.74-1.83-1.88/ 2.06-2.05-2.04	1.82-1.85-1.87/ 2.37-2.37-2.37	2.14-2.18-2.20/ 2.18-2.18-2.18	5.23-5.25-5.33/ 6.16-6.18-6.26	7.66-7.68-7.76/ 8.49-8.51-8.58	
Heating capacity (Nominal)	*3 kW	25.0	31.5	25.0	31.5	50.0	63.0	
	*3 BTU/h	85,300	107,500	85,300	107,500	170,600	215,000	
*2	Power input kW	0.490/0.680	1.05/1.26	1.00/1.41	1.31/1.41	2.86/3.79	3.94/5.30	
	Current input (380-400-415 V) A	0.97-0.98-0.99/ 1.24-1.23-1.22	1.74-1.83-1.88/ 2.06-2.05-2.04	1.82-1.85-1.87/ 2.37-2.37-2.37	2.14-2.18-2.20/ 2.18-2.18-2.18	5.23-5.25-5.33/ 6.16-6.18-6.26	7.66-7.68-7.76/ 8.49-8.51-8.58	
External finish		Galvanized steel plate (with polyester coating) <MUNSELL 3.0Y 7.8/1.1 or similar>						
External dimension H x W x D	mm	1,665 x 1,200 x 500	1,665 x 1,200 x 500	1,465 x 1,200 x 500	1,465 x 1,200 x 500	1,800 x 1,860 x 650	1,800 x 1,860 x 650	
	in.	65-9/16 x 47-1/4 x 19-11/16	65-9/16 x 47-1/4 x 19-11/16	57-11/16 x 47-1/4 x 19-11/16	57-11/16 x 47-1/4 x 19-11/16	70-7/8 x 73-1/4 x 25-5/8	70-7/8 x 73-1/4 x 25-5/8	
Net weight	kg (lbs)	157 (347)	158 (349)	138 (305)	139 (307)	310 (684)	362 (799)	
Heat exchanger		Cross fin (Aluminum fin and copper tube)						
Fan	Type x Quantity	Sirocco fan x 2		Sirocco fan x 2		Sirocco fan x 2		
	External static press. (380 V)	Pa	0	0	180/200	180/210	210/390	
		mmH <sub>2</sub> O	0.0	0.0	18.4/20.4	18.4/21.4	21.4/39.8	
Motor Type		3-phase induction motor						
	Motor output kW	0.400	0.500	0.770	0.770	3.700	5.500	
Driving mechanism		Direct-driven by motor				Belt driving		
Air flow rate	(High-Low)			(High)				
	m <sup>3</sup> /min	65.0-59.0/69.0-60.0	77.0-56.0/72.0-50.0	65.0	72.0	150.0	200.0	
	L/s	1,083-983/1,150-1,000	1,283-933/1,200-833	1,083	1,200	2,500	3,333	
	cfm	2,295-2,083/2,436-2,119	2,719-1,977/2,542-1,766	2,295	2,542	5,297	7,062	
Sound pressure level (measured in anechoic room) (380 V)	*2 dB (A)	(High-Low)			(High)			
		58-56/60-56	63-60/62-60	58/60	60/61	68/69	69/69	
Air filter		PP honeycomb fabric.						
Refrigerant piping diameter	Liquid (R410A)	mm (in.)	9.52 (3/8) Brazed	9.52 (3/8) Brazed	9.52 (3/8) Brazed	9.52 (3/8) Brazed	12.7 (1/2) Brazed	15.88 (5/8) Brazed
	Gas (R410A)	mm (in.)	22.2 (7/8) Brazed	22.2 (7/8) Brazed	22.2 (7/8) Brazed	22.2 (7/8) Brazed	28.58 (1-1/8) Brazed	28.58 (1-1/8) Brazed
Field drain pipe size		in.	Rc 1	Rc 1	Rc 1	Rc 1	Rc 1-1/4	Rc 1-1/4

## Notes:

- \*1 Nominal cooling conditions  
Indoor: 27°C D.B./19°C W.B. (81°F D.B./66°F W.B.), Outdoor: 35°C D.B. (95°F D.B.)  
Pipe length: 7.5 m (24-9/16 ft.), Level difference: 0 m (0 ft.)
- \*2 The values are measured in fan mode and at the factory setting of external static pressure.
- \*3 Nominal heating conditions  
Indoor: 20°C D.B. (68°F D.B.), Outdoor: 7°C D.B./6°C W.B. (45°F D.B./43°F W.B.)  
Pipe length: 7.5 m (24-9/16 ft.), Level difference: 0 m (0 ft.)
- \*4 Long period operation in a high temperature and humidity atmosphere (dew point of 23°C or more) may cause condensation to form in the indoor unit.
- \*5 In case of this type of unit is connected, the maximum connected indoor unit capacity to one outdoor unit have to be less than or equal to 100%.
- \*6 This unit cannot be connected to R2 or WR2-Series. (PFFY-P400, P500YM-E only)
- \*7 This unit cannot be connected to PUMY-Series.

\* Details on foundation work, duct work, insulation work, electrical wiring, power source switch, and other items shall be referred to the Installation Manual.  
\* Due to continuing improvement, above specifications may be subject to change without notice.



# Floor standing exposed type

## PFFY-P YM-E-F



### Enable intake of outside air

This model can take in the outside air, it delivers fresh air to indoors and improves comfort even in places where much ventilation is required, such as factories.

\*This product is for use in occupant spaces and not suitable for use in spaces requiring stringent thermostatic control.

\*Fresh air intake type is designed to supply conditioned outside air into the room. Do not use to handle internal thermal load.

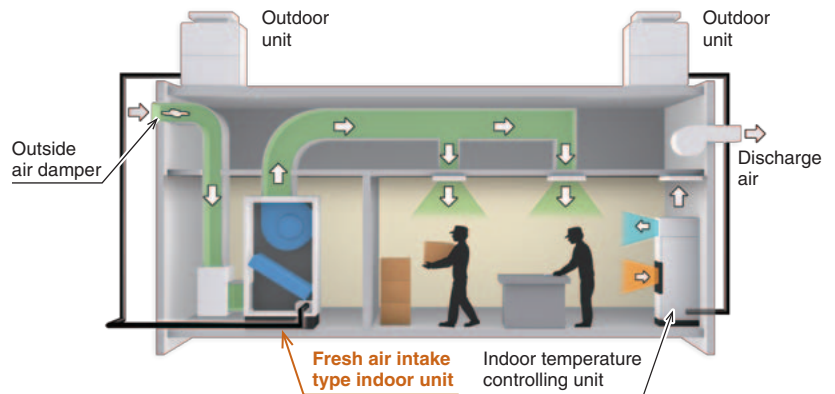

\*Please prepare dampers, ducts, and grilles locally in the field.

### Usable in combination with CITY MULTI indoor units

P300 is usable in combination with the CITY MULTI indoor units in a single refrigerant system\*.

By installing an outdoor unit and indoor units that match the size of each room, it is possible to achieve individual air conditioning and intaking fresh air.

\*When fresh air intake type indoor units connect to an outdoor unit together with other types of indoor unit, the total capacity of fresh air intake type indoor units needs to be 30% or less of the connected outdoor unit capacity. Please refer to NOTES of specification regarding the details.

#### Installation example

Example: Factory

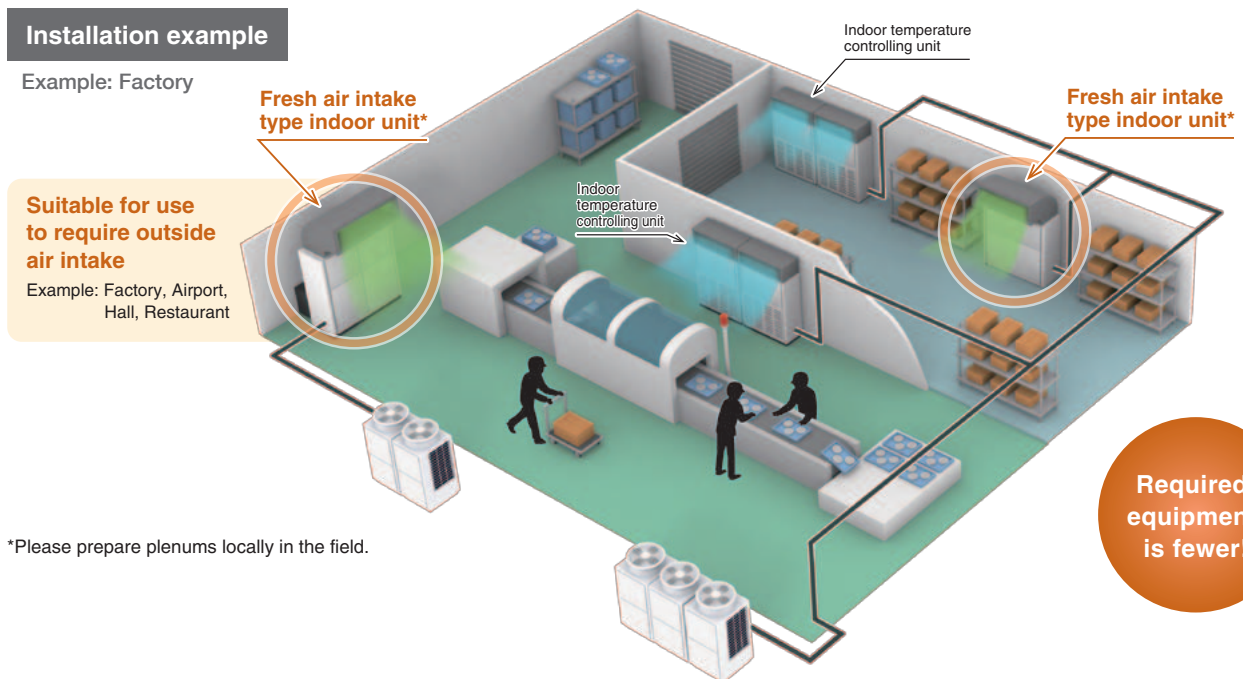

\*Please prepare plenums locally in the field.

### Air flow rate, external static pressure setting

The airflow rate of this product at High speed is 45 m<sup>3</sup>/min for the P300 model and 90 m<sup>3</sup>/min for the P600 model. Two patterns of static pressure setting are selectable, depending on the size and the use of the building.

	Air flow rate (m <sup>3</sup> /min)	External static pressure
	High	
PFFY-P300YM-E-F	45.0	80 Pa, 140 Pa
PFFY-P600YM-E-F	90.0	120 Pa, 200 Pa

# Specifications

Model		PFFY-P300YM-E-F		PFFY-P600YM-E-F	
Power source		3-phase 4-wire 380-400-415 V 50/60 Hz			
Cooling capacity (Nominal)	*1	kW	33.5	67.0	
	*1	BTU/h	114,300	228,600	
*2	Power input	kW	0.350-0.360-0.370/0.450-0.450-0.470	0.790-0.810-0.860/0.960-0.960-0.980	
	Current input	A	0.86-0.88-0.91/0.92-0.93-0.91	2.76-3.03-3.46/2.38-2.39-2.52	
Temp. range of cooling		21°C D.B./15.5°C W.B. ~ 43°C D.B./35°C W.B. * Thermo-off (FAN-mode) automatically starts if the outdoor temperature is lower than 21°C D.B.			
Heating capacity (Nominal)	*3	kW	28.0	56.0	
	*3	BTU/h	95,500	191,100	
*2	Power input	kW	0.350-0.360-0.370/0.450-0.450-0.470	0.790-0.810-0.860/0.960-0.960-0.980	
	Current input	A	0.86-0.88-0.91/0.92-0.93-0.91	2.76-3.03-3.46/2.38-2.39-2.52	
Temp. range of heating		0°C D.B. ~ 20°C D.B. * Thermo-off (FAN-mode) automatically starts if the outdoor temperature is higher than 20°C D.B.			
External finish		Galvanized steel plate (with polyester coating) <MUNSELL 3.0Y 7.8/1.1 or similar>			
External dimension H x W x D		mm	1,465 x 1,200 x 500	1,805 x 1,860 x 710	
		in.	57-11/16 x 47-1/4 x 19-11/16	71-1/8 x 73-1/4 x 28	
Net weight		kg (lbs)	146 (322)	357 (788)	
Heat exchanger		Cross fin (Aluminum fin and copper tube)		Cross fin (Aluminum fin and copper tube)	
Fan	Type x Quantity		Sirocco fan x 2		
	External static press.	Pa	80/140	120/200	
		mmH <sub>2</sub> O	8.2/14.3	12.2/20.4	
	Motor Type		3-phase induction motor		
	Motor output	kW	0.400	2.200	
	Driving mechanism		Direct-driven by motor		
	Air flow rate			(High)	
		m <sup>3</sup> /min		45.0	90.0
L/s			750	1,500	
cfm			1,589	3,178	
Sound pressure level (measured in anechoic room)				(High)	
*2		dB (A)	48.5/48.5	54.0/56.0	
Air filter		PP honeycomb fabric 1012 x 720 Dust collection efficiency (Weight Method) 17%		PP honeycomb fabric 894 x 612 x 2 Dust collection efficiency (Weight Method) 17%	
Refrigerant piping diameter	Liquid (R410A)	mm (in.)	9.52 (3/8) Brazed	15.88 (5/8) Brazed	
	Gas (R410A)	mm (in.)	22.2 (7/8) Brazed	28.58 (1-1/8) Brazed	
Field drain pipe size		Rc 1		Rc 1-1/4	

## Notes:

- \*1 Nominal cooling conditions  
Indoor: 33°C D.B./28°C W.B., Outdoor: 33°C D.B.  
Pipe length: 7.5 m (24-9/16 ft.), Level difference: 0 m (0 ft.)
- \*2 The values are measured in fan mode and at the factory setting of external static pressure.
- \*3 Nominal heating conditions  
Indoor: 7°C D.B., Outdoor: 7°C D.B./3°C W.B.  
Pipe length: 7.5 m (24-9/16 ft.), Level difference: 0 m (0 ft.)
- Long period operation in a high temperature and humidity atmosphere (dew point of 23°C or more) may cause condensation to form in the indoor unit.
- This unit cannot be connected to PUMY, R2 and WR2 series.
- Fresh air intake type indoor units cannot be connected to an outdoor unit together with PWFY series.
- When this fresh air intake type indoor unit is included in the system, the upper limit of connectable indoor unit capacity range is 100% of the connected outdoor unit capacity.
- When fresh air intake type indoor units connect to an outdoor unit together with other types of indoor unit, the total capacity of fresh air intake type indoor units needs to be 30% or less of the connected outdoor unit capacity.
- The actual capacity characteristics vary with the combination of indoor and outdoor units.  
See the technical information in DATA BOOK for the details.
- Thermo off (Fan) operation automatically starts either when temperature is lower than 21°C D.B. in cooling mode or when the temperature exceeds 20°C D.B. in heating mode.
- Dry mode is not available.
- When this unit is used as sole A/C system, be careful about the dew in air outlet grilles in cooling mode.
- Un-conditioned outdoor air such as humid air or cold air blows to the indoor during thermo off operation, which may occur dew condensation on the grills and ducts. Please insulate the grills, ducts, and rooms to prevent dew condensation properly.
- Air filter must be installed in the air intake side. The filter should be attached where easy maintenance is possible in case of usage of field supply filters.
- Fresh air intake type indoor unit is designed to supply pretreated outside air into the room.  
Do not use to handle internal thermal load.
- Depending on the air conditioning load, outside temperature, and due to the activation of protection functions, the desired preset temperature may not always be achieved and the outlet air temperature may swing.  
Note that untreated outside air may be delivered directly into the room upon the activation of protection functions.
- The fan temporary stops during defrost.

\* Details on foundation work, duct work, insulation work, electrical wiring, power source switch, and other items shall be referred to the Installation Manual.  
\* Due to continuing improvement, above specifications may be subject to change without notice.





# Remote Controller



## Remote controller list

## Building Management Zone

Centralized control



LonWorks® Adapter

**LMAP04-E**

For LonWorks®



\*This image shows AE-200E.

**AE-200E/EW-50E with BACnet Interface**

For BACnet®

**BMS and CITY MULTI can be connected. This enables control of the entire building and air-conditioning control on the BMS side.**

## Floor Management Zone

System controller

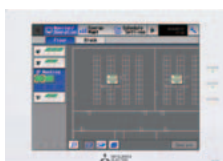
**AE-200E**

This model, featuring a color LCD screen, can control up to 50 indoor units when used independently, and up to 200 indoor units when connected to AE-50E/EW-50E.

**EW-50E**

This model can control up to 50 indoor units when used independently, or when connected to the AE-200E as an expansion unit.

**PAC-YT40ANRA**

The power can be turned on and off easily for 50 indoor units in up to 16 groups with this single unit.

**AT-50B**

This model is suitable for control on each floor. You can control up to 50 indoor units on the color LCD screen.

**The air conditioners in each group can be turned on and off, and their modes can be changed. The weekly timer allows them to be turned on automatically before work starts, and off after closing time.**

Local remote controller

**PAR-41MAA** NEW  
(MA remote controller)

The temperature can be set in steps of 0.5°C [1°F] increments, and the air flow direction and error icons are displayed on the screen.

**PAR-21MAA**  
(MA remote controller)

The temperature can be set in steps of 1°C/1°F increments. The button panel can be accessed and closed when the buttons are not used.

**PAR-U02MEDA**  
(ME remote controller)

All elements appear on the LCD screen, which features an occupancy sensor. All conditions including grouping can be set on this one controller.

**PAC-YT52CRA**  
(MA remote controller)

A simple remote controller dedicated to setting the temperature and fan speed

**PAR-CT01MAA-S**  
(MA remote controller)

All elements appear on the LCD screen. The background and character colors can be selected.

**PAR-SL101A-E**  
(MA Wireless remote controller)

\* Connected only to PLFY-P VEM-PA / PLFY-P VFM-E1/PKFY-P VLM-E  
\* Requires wireless signal receiving unit

**PAR-FL32MA**  
(MA Wireless remote controller)

\* Requires wireless signal receiving unit

**A suitable remote controller can be selected to control the air conditioners in each room according to each use situation.**

**Building management system**

**System controller**



AE-200E



EW-50E



AT-50B



PAC-YT40ANRA



**Expansion interface**

PI Controller



DIDO Controller



AI Controller



PAC-SC51KUA

Power supply unit for transmission line

PAC-SF46EPA-F

Transmission booster

Extension of air conditioner functions

LON Works®

LMAP04-E

BACnet®

EW-50E  
AE-200E

M-NET

M-NET

## M-NET

Using our MELANS products enhances air-conditioning EFFICIENCY and QUALITY, contributing to ENERGY SAVINGS and reducing running cost. We offer a wide variety of MELANS products to meet requirements - from the smallest and simplest, to the largest and most complex. We have individual remote controllers, various centralized controllers, BMS interface, etc.

Local remote controller

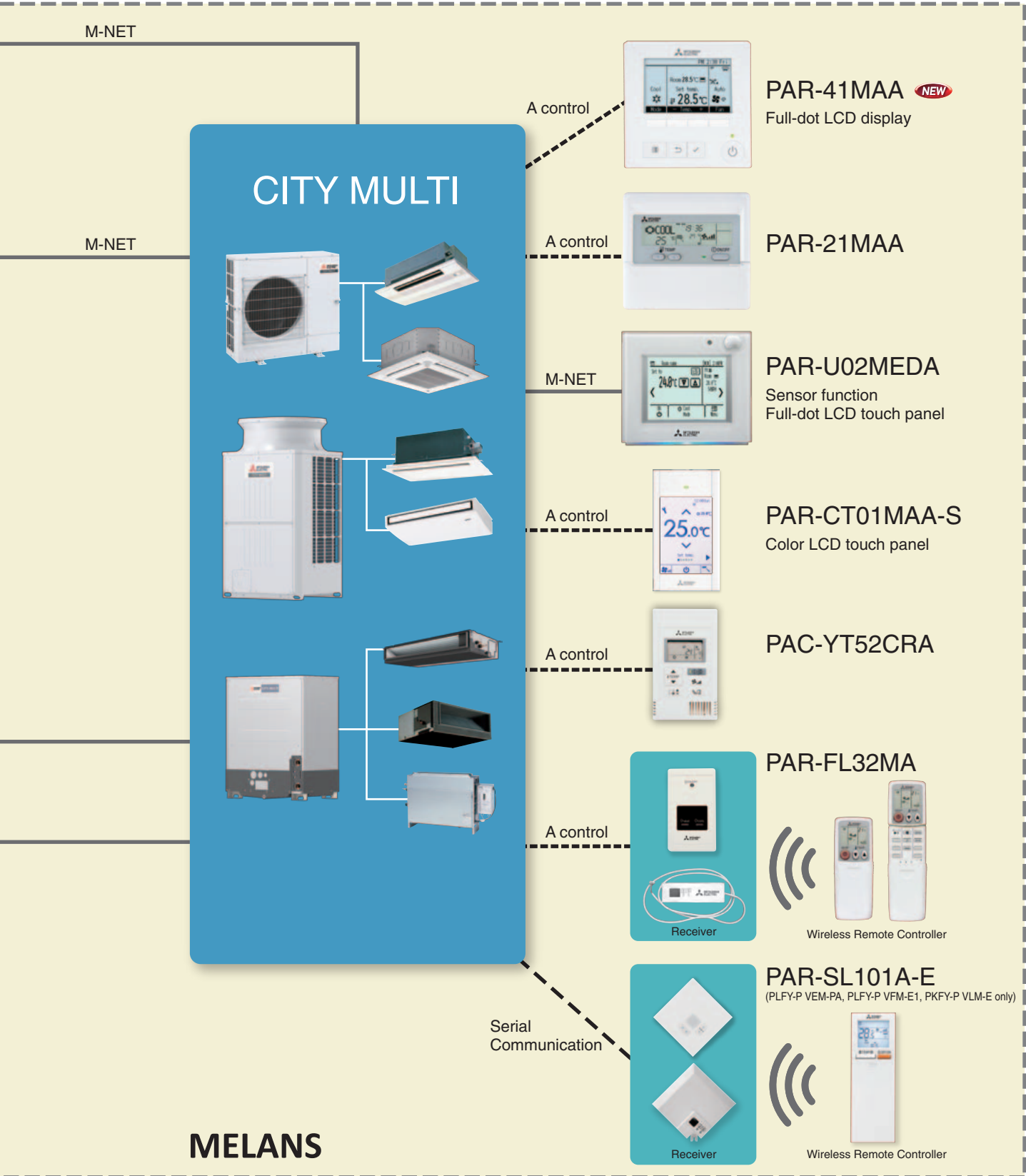

Advantages of CITY MULTI

Outdoor/Heat source unit

Indoor unit

Remote Controller

Lossnay

Installation information



# Integrated Communications Control with Mitsubishi Electric Unique Transmission Network (M-NET)

Model	Local remote controller <sup>17</sup>							System controller <sup>17</sup>							
	PAR-41MAA	PAR-21MAA	PAR-U02MEDA	PAR-CT01MAA-S	PAC-YT52CRA	PAR-FL32MA	PAR-SL101A-E	PAC-YT40ANRA	AT-50B	AE-200E		AE-200E + AE-50E / EW-50E		EW-50E	
Controllable Groups / Indoors (Group / Indoor) <sup>16</sup>	1 / 16	1 / 16	1 / 16	1 / 16	1 / 16	1 / 16	1 / 1	16 / 50	50 / 50	50 / 50		200 / 200		50 / 50	
										AE-200E	Browser	AE-200E	Browser	EW-50E	Browser

## ■Operation

ON / OFF	○	○	○	○	○	○	○	◎	◎	◎■	◎■	◎■	◎■	▲	◎■
Mode (cool / heat / dry / fan)	○	○	○	○	○	○	○	N	◎	◎■	◎■	◎■	◎■	N	◎■
Temperature setting	○	○	○	○	○	○	○	N	◎	◎■	◎■	◎■	◎■	N	◎■
Relative temperature display	N	N	N	○	N	N	N	N	N	N	N	N	N	N	N
Dual set point <sup>18</sup>	○	N	○	○	○	N	○ <sup>19</sup>	○ <sup>10</sup>	◎	◎■	◎■	◎■	◎■	N	◎■
Local Permit / Prohibit	N	N	N	N	N	N	N	N	◎	◎■	◎■	◎■	◎■	N	◎■
Fan speed	○	○	○	○	○	○	○	N	◎	◎■	◎■	◎■	◎■	N	◎■
Air flow direction	○	○	○	○	○	○	○	N	◎	◎■	◎■	◎■	◎■	N	◎■

## ■Status monitoring

ON / OFF	○	○	○	○	○	○	○	◎	◎	◎	○	◎	○	▲	○
Mode (cool / heat / dry / fan)	○	○	○	○	○	○	○	N	○	○	○	○	○	N	○
Temperature setting	○	○	○	○	○	○	○	N	○	○	○	○	○	N	○
Local Permit / Prohibit	○	○	○	○	○	N	N	○	○	○	○	○	○	N	○
Fan speed	○	○	○	○	○	○	○	N	○	○	○	○	○	N	○
Air flow direction	○	○	○	○	○	○	○	N	○	○	○	○	○	N	○
Indoor temperature	○	○	○	○	○	N	N	N	○	○	○	○	○	N	○
Filter sign	○	○	○	○	N	N	N	N	◎	○	○	○	○	N	○
Error flashing	○	○	○	○	○	N	N	○	◎	○	○	○	○	▲	○
Error code	○	○	○	○	○	N	N	○	○	○	○	○	○	N	○
Operation hour	N	N	N	N	N	N	N	N	N	N	N	N	N	N	N

## ■Scheduling

One day	○	○	○	○	N	N	N	N	○	◎■	◎■	◎■	◎■	N	◎■
ON / OFF times per day	1	8	1	1	N	1	1	N	16	24	24	24	24	N	24
Weekly	○	○	○	○	N	N	N	N	○	◎■	◎■	◎■	◎■	N	◎■
ON / OFF times per week	8 x 7	8 x 7	8 x 7	8 x 7	N	N	N	N	16 x 7	24 x 7	24 x 7	24 x 7	24 x 7	N	24 x 7
Annual	N	N	N	N	N	N	N	N	N	◎■	◎■	◎■	◎■	N	◎■
Optimized start-up	N	N	N	N	N	N	N	N	N	○	○	○	○	N	○
Auto-off timer	○	○	○	○	N	N	N	N	N	N	N	N	N	N	N
Min. timer setting unit (minute)	5	1	5	5	N	10	10	N	5	1	1	1	1	N	1

## ■Recording

Error log	○	N	N	○	N	N	N	N	○	○	○	○	○	N	○
Daily / monthly report	N	N	N	N	N	N	N	N	N	N	N	N	N	N	N
Electricity charge	N	N	N	N	N	N	N	N	N	N	N	●	N	N	N
Energy management data	N	N	N	N	N	N	N	N	N	●	●	●	●	N	●



Model	Local remote controller <sup>*7</sup>							System controller <sup>*7</sup>							
	PAR-41MAA	PAR-21MAA	PAR-U02MEDA	PAR-CT01MAA-S	PAC-YT52CRA	PAR-FL32MA	PAR-SL101A-E	PAC-YT40ANRA	AT-50B	AE-200E		AE-200E + AE-50E / EW-50E		EW-50E	
Controllable Groups / Indoors (Group / Indoor) <sup>*6</sup>	1 / 16	1 / 16	1 / 16	1 / 16	1 / 16	1 / 16	1 / 1	16 / 50	50 / 50	50 / 50		200 / 200		50 / 50	
										AE-200E	Browser	AE-200E	Browser	EW-50E	Browser

### ■Other

Temp-set limitation by Local R / C	○	○	○	○	○	N	N	N	N	N	N	N	N	N	N
Temp-set limitation by System controller	○ <sup>*4</sup>	○ <sup>*4</sup>	○	○ <sup>*4</sup>	○ <sup>*4</sup>	N	N	N	○ <sup>*4</sup>	N	○ <sup>*2*</sup>	○ <sup>*2*</sup>	○ <sup>*2*</sup>	N	○ <sup>*2*</sup>
Operation lock	○	○	○	○	○	N	N	N	◎	N	N	N	N	N	N
Night setback	○	N	○	○	N	N	N	N	◎	○	○ <sup>2</sup>	○	○ <sup>2</sup>	N	○ <sup>2</sup>
Sliding temperature control	N	N	N	N	N	N	N	N	N	○	○ <sup>2</sup>	○	○ <sup>2</sup>	N	○ <sup>2</sup>
BACnet® connection	N	N	N	N	N	N	N	N	N	●	●	●	●	●	●

### ■Management (Group / Interlocked)

Group setting	○ <sup>*1</sup>	○ <sup>*1</sup>	○	○ <sup>*1</sup>	○ <sup>*1</sup>	N	N	○	○	○	○ <sup>2</sup>	○	○ <sup>2</sup>	N	○ <sup>2</sup>
Block setting	N	N	N	N	N	N	N	N	N	○	○ <sup>2</sup>	○	○ <sup>2</sup>	N	○ <sup>2</sup>

### ■Operating on LOSSNAY interlocked (Group / Interlocked)

ON / OFF	N / ○	N / ○	N / ○	N / ○	N / ○	N / ○ <sup>5</sup>	N / ○ <sup>5</sup>	◎ / ◎ <sup>3</sup>	◎ / ◎	◎ / ◎	◎ / ◎	◎ / ◎	◎ / ◎	◎ / ◎	▲ / ▲	◎ / ◎
Fan speed	N / ○	N / ○	N / ○	N / ○	N	N	N	N	◎ / ◎	◎ / ◎	◎ / ◎	◎ / ◎	◎ / ◎	N	◎ / ◎	
Ventilation mode	N	N	N	N	N	N	N	N	◎ / N	◎ / N	◎ / N	◎ / N	◎ / N	N	◎ / N	

### ■Status monitoring on LOSSNAY interlocked (Group / Interlocked)

ON / OFF	N / ○	N / ○	N / ○	N / ○	N / ○	N	N	N	○ / ○	◎ / ◎	◎ / ◎	◎ / ◎	◎ / ◎	◎ / ◎	▲ / ▲	◎ / ◎
Fan speed	N / ○	N / ○	N / ○	N / ○	N	N	N	N	○ / ○	○ / ○	○ / ○	○ / ○	○ / ○	N	○ / ○	
Ventilation mode	N	N	N	N	N	N	N	N	○ / N	○ / N	○ / N	○ / N	○ / N	N	○ / N	

◎: Each group / Batched ; ○: Each group ; □: Block (for CITY MULTI Indoor unit, not for all Mr.SLIM) ; ●: AE-200E/AE-50E/EW-50E license registration possible.  
 (●): License registration for the optional functions required N: Not Available (Not Used.) △: Batched only ; ▲: Batched handling (for maintenance) ■: Block

\*1. Group setting via wiring between Indoor units with cross-over cable;

\*2. Setting via the integrated web browser is possible for Ver. 7.7 or later.

\*3. Interlock is set at Local remote controller.

\*4. This function can only be set on the ME remote controller.

This function cannot be used with the MA/Simple MA remote controller.

(However, the validity of this function with the MA/Simple MA remote controller depends on the indoor unit model, and it is possible to use this function with them.)

\*5. Interlock is set from system controllers (Except PAC-YT40ANRA) or local remote controllers.

\*6. The maximum number of controllable units decreases depending on the indoor unit model.

\*7. For indoor use only.

\*8. This function is supported only when all of the indoor units, remote controllers, and system controllers that are connected to a given group features said function.

\*9. Function setting of this remote controller is necessary.

\*10. Please contact your local distributor regarding the availability of this function.

#### Air conditioner control system interface

LMAP04-E: LonWorks® Interface

Controls up to 50 Groups/ 50 units, for details, refer to its description.

## Optional Parts For Control

Model	Description
PAC-SE41TS-E	Remote Sensor for A/J/K/M-Net Control
PAC-SE55RA-E	Remote ON/OFF adaptor for Indoor Unit
PAC-SA88HA-EP	Remote Display Adaptor for Indoor Unit
PAC-SC37SA-E	Output signal connector
PAC-SC36NA-E	Input signal connector
PAC-SF46EPA-G	Transmission booster
PAC-SC51KUA	Power supply unit
PAC-YT51HAA-J	External input/output adaptor for AT-50B
PAC-YG10HA-E	External input/output adaptor for AE-200E
PAC-YG82TB-J	Mounting attachment for AE-200E wall-mount installations
PAC-YG84UTB-J	Electrical box for AE-200E wall-embed installations
PAC-YG86TK-J	Mounting kit for AE-200E wall-mount installations
PAC-YG72CWL-J	Surface cover with USB port for AE-200E

# Centralized Remote Controller

Centralized controller

## AE-200E/AE-50E

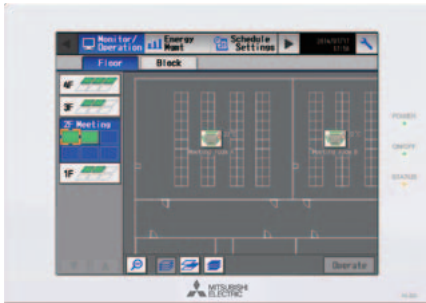

**Dimensions** 284(W) x 200(H) x 65(D) mm  
11-3/16(W) x 7-7/8(H) x 2-9/16(D) in.

### Mounted with color LCD touch panel excelling in visibility and operability.

- A 10.4-in LCD touch panel with high definition is used. The large display screen and the floor screen image\*1 are excellent in visibility, and the equipment can be operated by touching the icons on the touch panel.

\*1. The floor plan image function is optional.

### An optimal system can be easily and flexibly established according to a facility's scale.

- Up to 50 indoor units can be managed.
- Centralized control of up to 200 indoor units can be performed with three "AE-50E/EW-50E" expansion controllers.
- More than 200 indoor units can be managed by connecting the PC to the web browser.\*1

\*1. Please contact your local distributor regarding support for this feature.

### Airflow direction and airflow rate can be adjusted finely according to the schedule.

- For indoor units, LOSSNAY and general-purpose devices controlled by AE-200E, schedules by group, block and floor and for the entire building can be set.

### Detailed settings for each indoor unit can also be managed from the AE-200E

**Presetting of set temperature**  
Even if the set temperature is changed on a remote controller, the temperature can be automatically returned to the standard temperature at the specified time.

**Prevention of forgetting to turn off**  
A command to stop can be given to prevent forgetting to turn off.

**Change of set temperature according to time slot**  
The set temperature in each time slot can be changed.

**Prohibition of operation of remote controllers**  
It is possible to prohibit operation (ON/OFF, change operation mode, set temperature.) of the remote controllers.

**Air flow direction and fan speed can be set**  
The air flow direction and fan speed can be set. The detailed setting improves the comfort.

**Can be set from the Web browser.**

**Operation items to be prohibited can be selected arbitrarily.**

**24 times of actions per day can be set in minutes.**

### Comparing the number of connectable units

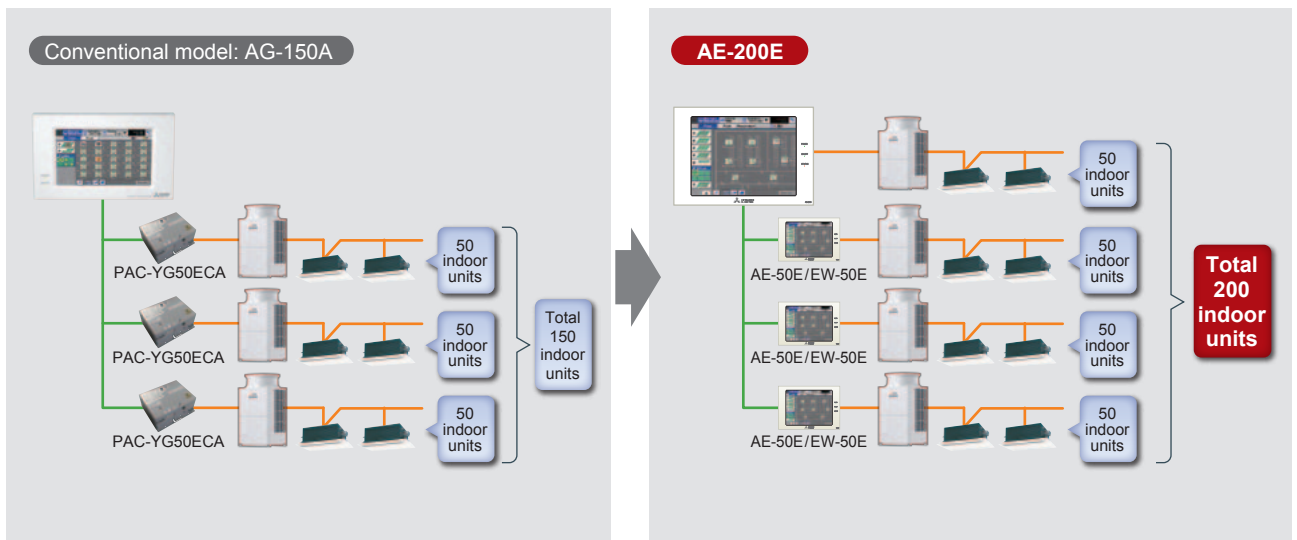

### System Structure

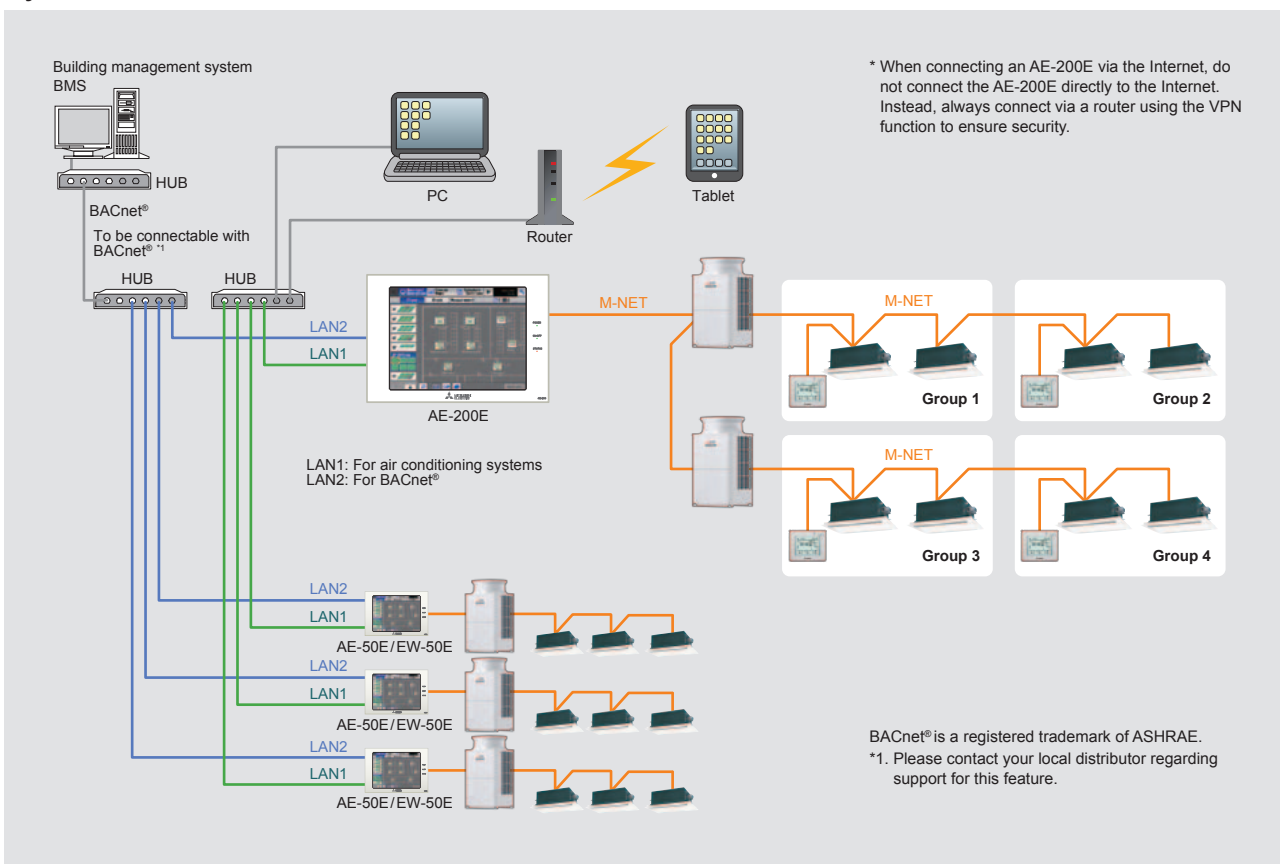

### Functions

□: Each unit ○: Each group ●: Each block △: Each floor ⊙: Collective ×: Not available

Item	Description	Setting	Display
Controllable number of units	Up to 50 units/50 groups		
ON/OFF	ON and OFF operation for the air conditioning units and general equipment. (PAC-YG66DCA is required to operate general equipment.)	○ ⊙ △ ●	○ ⊙
Operation mode	Switches between several operation modes depending on the air conditioning unit. Air conditioning unit: Cool/Dry/Auto(*)/Fan/Heat LOSSNAY unit: Heat Recovery/Bypass/Auto * Auto mode is for CITY MULTI R2 and WR2 Series only.	○ ⊙ △ ●	○
Temperature setting	Changes the set temperature. * Set temperature range varies depending on the indoor unit model.	○ ⊙ △ ●	○
Fan speed setting	Models with 4 air flow speed settings: Hi/Mid-2/Mid-1/Low Models with 3 air flow speed settings: Hi/Mid/Low Models with 2 air flow speed settings: Hi/Low Fan speed setting (including Auto) varies depending on the model.	○ ⊙ △ ●	○
Air flow direction setting	Air flow direction angles, 4-angles or 5-angles Swing, Auto (Louver cannot be set)	○ ⊙ △ ●	○
Schedule operation	Weekly schedule can be set by groups based on daily operation pattern.	○ ⊙ △ ●	○
Permit/prohibit local operation	Individually prohibits operation of each local remote controller function. (ON/OFF, Operation mode, Set temperature, Filter sign reset, Air Direction*, Fan Speed*, Timer*) * This function depends on the model.	○ ⊙ △ ●	○
Indoor unit intake temperature	Measures the intake temperature of the indoor unit only when the indoor unit is operating.	×	○
Error	When an error is currently occurring on an air conditioning unit, the affected unit and the error code are displayed.	×	□ ⊙
Test run	This operates air conditioning units in test run mode.	○ ⊙ △ ●	○
Ventilation interlock	The ventilation unit (LOSSNAY) is able to automatically start its operation when operation of the interlocked indoor unit starts.	○ ⊙ △ ●	○
External input (timer connection, emergency stop input, etc.)	Using a level signal or pulse signal, it is possible to input the following: Level signal: Emergency Stop Input, Batch ON/OFF, and Demand Input. Pulse signal: Batch ON/OFF or Operation Disable/Enable * Requires an external power supply and external I/O adapter (PAC-YG10HA) sold separately. Only one input can be selected from the above inputs.	⊙	⊙
Energy Management	Bar Graph: Indoor unit Electric Energy, FAN operation time, Thermo-ON time (TOTAL, Cooling, Heating) can be displayed hourly, daily, and monthly. Line Graph: Outdoor temp., Room temp., Set temp. (Heating, Cooling) input from PAC-YG63MCA.	×	□ ○ ● *3
ME remote controller	The status of sensor on this controller can be monitored.	×	○
Smartphone/Tablet	The specified web browser on iOS and Android OS can monitor and operate the AE-200E. *1	○	○
New web design	Revised web screen design for a more user friendly interface. *1	○ ⊙ △ ●	○
Apportionment of power consumption	Apportionment of power consumption can be calculated on the AE-200 *2	●	□ ○ ● *3
BACnet® communication	ANSI/ASHRAE 135-2010 (ISO16484-5) is supported and approved by the BTL. *1	○	× *3

\*1. Please contact your local distributor regarding support for this feature.  
\*2. Even when the number of indoor units is 50 or less, the system must consist of AE-200E and EW-50E/AE-50E.  
\*3. Energy Management License Pack (optional) is required.



## Example of AE-200E Functions

### Remote air conditioner operation in each room from the front desk

For Hotels

The air conditioner in each room can be remotely operated from the AE-200E installed at the front desk. It is unnecessary to keep air conditioners running; the rooms are air-conditioned before guests enter. All air conditioners in the hotel can be controlled using the scheduling function.

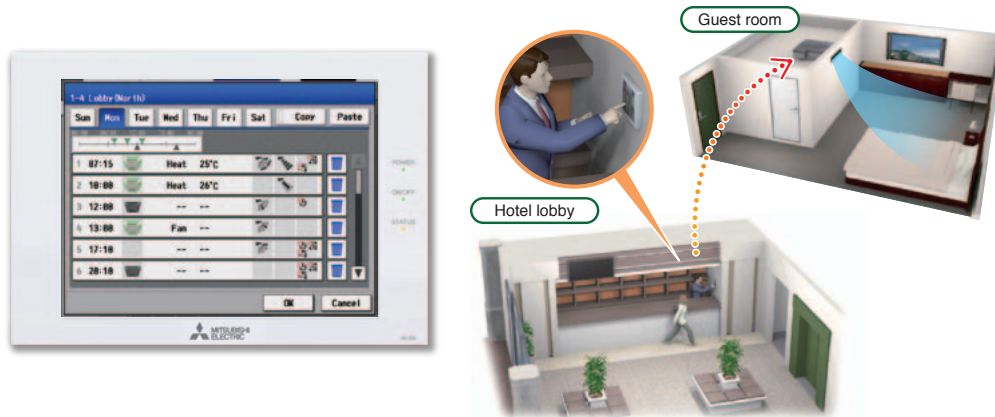

### Operation and monitoring using a web browser\*

Air conditioning units can be operated and monitored from LAN-connected personal computers, tablets, and smartphones. You can easily see the operation conditions of units in the same manner as when browsing a website.

For Hotels

\* A Wi-Fi router is required to use this function.

#### ▶ With AE-200E + Smartphone:



#### System configuration

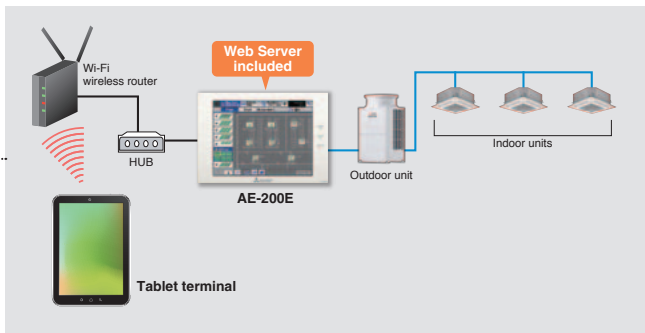

You can control air conditioners that have not been turned off while on patrol right from your tablet without returning to the central management office.

For Offices

\* A Wi-Fi router is required to use this function.

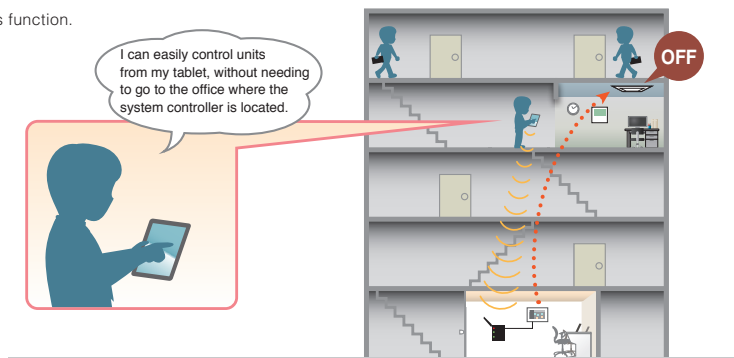

# Centralized Remote Controller

Centralized controller

## EW-50E



Dimensions

209(W) x 172(H) x 92(D) mm  
8-1/4(W) x 6-25/32(H) x 3-5/8(D) in.

### Main Features

• **Can be used as an expansion controller for the AE-200E**  
Up to 200 indoor units can be operated and monitored by connecting three EW-50E units to an AE-200E controller.

• **Function to apportion electricity charges**

The power consumption of each air conditioner can be calculated with an AE-200E controller. The calculated data can be output to a PC via a USB memory device or LAN, and billing charges can be prepared using a specific charge calculation tool.

\*To use the function to apportion electricity charge, the AE-200E and EW-50E are required.

\*For other restrictions, refer to the Installation Manual and Instruction Book.

### System Structure

#### System diagram (standard)

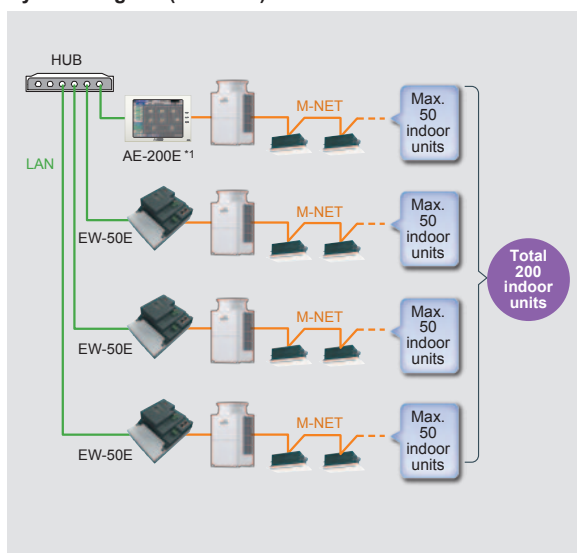

\* 1. When the AE-200E M-NET is not used, a maximum of four EW-50E units can be connected.

#### System diagram (with charge setting)

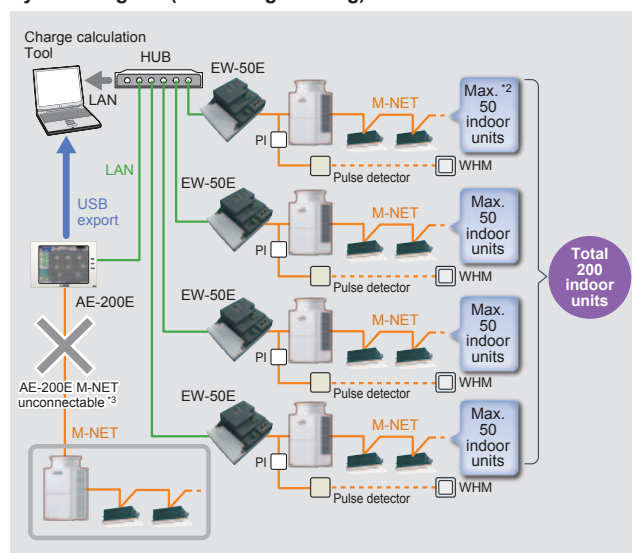

\* 2. When connecting a PI controller or other device, the number of each connected device is counted in the same method as an indoor unit.

\* 3. Even when the number of indoor units is 50 or less, the system must consist of AE-200E and EW-50E/AE-50E.

• **Air conditioner units can be operated and monitored independently using a PC**

Even without an AE-200E controller, the EW-50E can operate and monitor air conditioner units using browser software\*1.

Air conditioners can be operated and monitored remotely via the Internet. In addition, air conditioners in multiple buildings can be operated collectively.\*2

\* 1. This operation has been confirmed on Internet Explorer 11, Edge or on Google Chrome ver.83, and Safari 13.

It is recommended to use a browser other than Microsoft Internet Explorer because Microsoft will end the support for Internet Explorer 11 in June 2022.

Microsoft® Internet Explorer is a trademark or registered trademark of Microsoft Corporation in the United States and other countries.

Google is a registered trademark of Google LLC.

Google Chrome is a registered trademark of Google LLC. in the U.S. and other countries.

Edge is a trademark or registered trademark of Microsoft Corporation in the U.S. and other countries.

Safari is a trademark or registered trademark of Apple Inc. in the U.S.

Company names and product names in this brochure may be trademarks or registered trademarks of the respective rights holder.

\* 2. When connecting an EW-50E via the Internet, do not connect the EW-50E directly to the Internet. Instead, always connect via a router using the VPN function to ensure security.

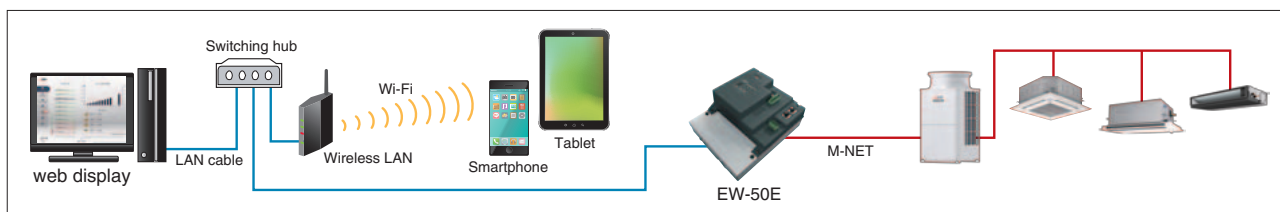



## • Manage air conditioner usage conditions

Energy consumption of air conditioners can be displayed in an easy-to-understand manner using a web browser.

\* Energy Management License Pack (optional) is required.

\* For the billing function, PI Controller and watt-hour meter with pulse transmitter (locally available one) are required.



## • Operable without the transmission line power supply unit

The EW-50E unit is equipped with a power supply function. Power supplied by a transmission line power supply unit is not necessary. Since an outside power supply is not needed, self-sustained operation is possible even when the outdoor unit system is down. (In cases where the power consumption factor exceeds 1.5, a power supply unit is needed.)

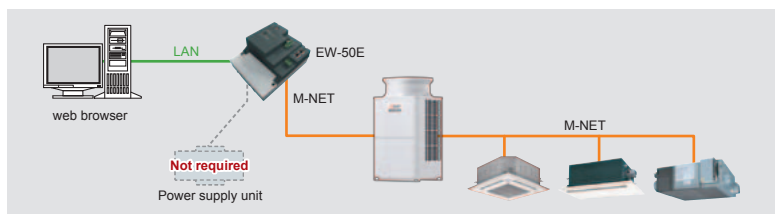

## • Energy-saving control

With the addition of an energy-saving control license (optional product), the set temperature can be automatically changed\* according to the room temperature around the air conditioner unit to allow greater energy savings without sacrificing comfort.

\* 1. With this function, the set temperature can be changed in +2°C/4°F increments for cooling and -2°C/4°F increments for heating during a set time interval.

In cases where the intake temperature and the set temperature are significantly different, exclusion from the energy-saving target is possible.

## Functions

\* The functions and specifications are subject to change.

☉: By group or multiple groups ○: By group □: Batch only

Item	Remarks	Setting	Display
ON/OFF	Switches air conditioners and general equipment ON or OFF.	☉	☉
Operation mode switching	Switches to cool, dry, auto, fan, or heat operation. * Some modes are not available depending on the unit.	☉	○
Temperature setting	Changes the set temperature. * Set temperature range varies depending on the indoor unit model.	☉	○
Set temperature 0.5°C/1°F increments	The temperature can be set and displayed in 0.5°C/1°F increments. * With some unit combinations, the temperature is set in 1°C/2°F increments.	☉	○
Fan speed setting	The fan speed can be set to 4 levels, 3 levels, 2 levels, or automatic. * Available fan speeds differ depending on the unit.	☉	○
Air direction setting	Fixed swing in 5 levels or auto air direction can be set. * Available air directions differ depending on the unit.	☉	○
Prohibition of local remote controller operation	It is possible to disable the ability to use to local remote controller to run or stop the operation mode, set temperature, filter sign reset, wind speed, wind direction and timer operation. * In the Lossnay group, only ON/OFF and filter reset can be disabled. * Disabling of the fan speed, air direction, and timer operation can be set for the AT-50B, PAR-41MAA, PAR-U02MEDA, and PAC-YT52CR models.	☉	○
Room temperature display	Displays the suction temperature of the indoor unit.	—	○
Error display	Displays the current error content together with the address.	—	☉
Schedule operation	Today/weekly/weekly by season/yearly Setting content: ON/OFF, operation mode, set temperature, disable local remote controller, air direction/fan	☉	○
Energy management	Displays the power consumption* or operating hours. * Optional part required.	—	☉
Ventilator operation (solo)	Group operation is possible for free plan Lossnay units only. * The above group operation mode includes auto ventilation, heat exchange, and normal ventilation.	☉	○
Ventilator operation (interlocked)	Free plan Lossnay units and indoor units can be interlocked and operated together. * At this point, air volume can be operated, but the ventilation mode cannot be selected.	☉	○
External input (timer connection, emergency stop input, etc.)	Using a level signal or pulse signal, it is possible to input the following: Level signal: Emergency Stop Input, Batch ON/OFF, and Demand Input. Pulse signal: Batch ON/OFF or Operation Disable/Enable * Requires an external power supply and external I/O adapter (PAC-YG10HA) sold separately. Only one input can be selected from the above inputs.	□	—
External output (error output, operation output)	Using the level signal, ON/OFF, and Error/Normal are output. * Requires an external power supply and external I/O adapter (PAC-YG10HA) sold separately.	—	□
Web browser	Monitor/operation, failure, filter sign monitoring, schedule setting, interlocked control setting (option), energy-saving control setting (option), energy-saving peak cut setting (option), set temperature range restrictions, other	☉ <sup>*1</sup>	☉ <sup>*1</sup>
Filter reset	Filter sign reset	○	○
Connectable location	Centralized system transmission line: Connectable Recommended Indoor and outdoor transmission line: Connectable	—	—

\* Functions and specifications differ depending on the connected equipment and model.

\* Electric energy can be proportionally divided using the EW-50E alone.  
However, the apportioned electricity charge function requires an AE-200E.

### ■Notes

\* 1. Some items do not support the multi group setting and display.

### ■Connectable equipment: CITY MULTI

A Mr. SLIM Control (Can be connected using an M-NET adapter or special outdoor unit)  
Room air conditioner (Requires a system control interface or M-NET control interface)  
Lossnay  
AI controller, PI controller, DIDO controller

# Centralized Remote Controller

Advanced Touch controller

## AT-50B



**Dimensions** 180(W) x 120(H) x 30(D) mm  
7-2/16(W) x 4-3/4(H) x 1-3/16(D) in.

The color touch panel is easy to see and operate. The operation screen can be selected according to the intended use.

### System structure

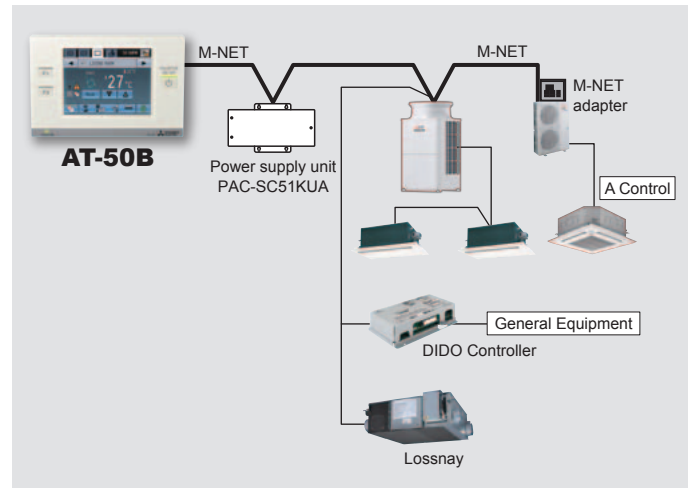

## Design

### Backlit LCD Touch Panel

The 5-inch color LCD (Liquid Crystal Display) touch panel enables easy and simple operations. When the backlight is off, touching the panel turns on the backlight. The backlight will remain on for a preset length of time. The touch panel displays operation status of the units in GRID, LIST, or in GROUP form.



#### GRID (zoom out) screen

Displays operation status of all groups.



#### GRID (zoom in) screen

Displays the operation status details of each group by group name.



#### LIST screen

Displays the operation status details of each group.



#### GROUP screen

Displays the operation status details of each group. Sets group operations.

## Functions

### Controls 50 indoor units in all

One screen shows the operation conditions of 50 connected indoor units.

### Weekly and daily schedule

Five one-day schedule patterns and 12 weekly schedule patterns (max. 16 settings per pattern)

Two weekly schedules can be set.

### System changeover

The operation mode can be changed according to the indoor temperature settings, target temperature of each group, or a representative indoor unit.

### Main system controller/Sub-system controller

The AT-50B can be used as any of the main and sub system controllers. When it is connected to a system controller, such as the AE-200E, it is used as a sub controller. When some units of the AT-50B are connected, the main and sub controllers can be determined.

### Night setback function

When the room temperature goes outside of a certain range during the predetermined period, this function automatically starts heating or cooling operation to prevent dew condensation or an excessive temperature increase in the room.

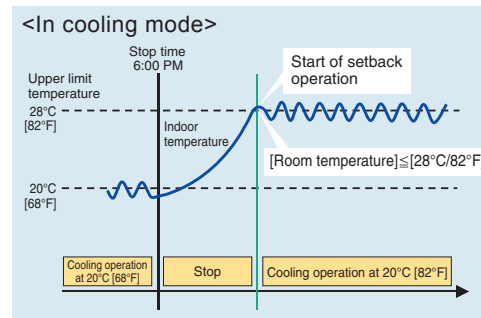

### Simple button arrangement

The F1 and F2 buttons beside the main screen can be customized for frequently used functions. (Schedule/Operation Mode/Temperature Correction/Remote Controller Restriction)

### Functions [Basic Functions]

- ON/OFF
- Temperature setting
- Airflow direction setting
- Operation mode switching
- Fan speed setting
- Louver setting

### Advanced Functions

Each unit    Each group    Group or collective    Not available

Item	Description	Setting	Display
Permit / Prohibit	The ON/OFF, operation mode, setting temperature, fan speed, air direction, filter sign reset operations, and timer using the local remote controllers can be prohibited. Only ON/OFF and filter reset can be prohibited for the LOSSNAY group. *The settable items vary depending on the models.	<input checked="" type="radio"/>	<input checked="" type="radio"/>
Operation lock	The operation lock can be set to the input operation of the AT-50B. Each button can be set. (Function Button 1, Function Button 2, Collective ON/OFF, Touch Panel) Each function can be set. (Operation mode, Setting temperature, Fan speed, Menu button) The password for the lock release can be set.	<input type="radio"/>	<input checked="" type="radio"/>
Error display	When an error is occurring on an air conditioner unit, the affected unit and the error code are displayed. * When an error occurs, the "ON/OFF" LED flashes. The operation monitor screen shows an abnormal icon over the unit. The error monitor screen shows the abnormal unit address and error code. The error log monitor screen shows the time and date, the abnormal unit address, error code, and source of detection.	<input type="checkbox"/>	<input type="checkbox"/> <input checked="" type="radio"/>
Ventilation (independent)	Switches the mode "Bypass/Heat recovery/Auto" for LOSSNAY groups.	<input type="radio"/>	<input checked="" type="radio"/>
Ventilation (interlocked)	The LOSSNAY will run in interlock with the operation of the indoor unit. The mode cannot be changed. The LED will turn ON during operation after interlocking.	<input type="radio"/>	<input checked="" type="radio"/>
Temperature set limitation	Batch-setting to temperature range limit in cooling, heating, and auto modes. This function cannot be used with the MA remote controller. (Depends on the indoor unit model.)	<input type="radio"/>	<input checked="" type="radio"/>
Specific mode operation prohibit (Cooling prohibit, heating prohibit, cooling/heating prohibit)	When set as the main controller, operation of the following modes with the local remote controllers can be prohibited: When cooling is prohibited: Cooling, dry, automatic can not be chosen. When heating is prohibited: Heating, automatic can not be chosen. When cooling/heating is prohibited: Cooling, dry, heating, automatic can not be chosen.	<input type="radio"/>	<input checked="" type="radio"/>
External input (Emergency stop input, etc.)	The following input with level signals or pulse signals are available. Level signal: "Emergency stop input" or "Collective ON/OFF" Pulse signal: "Collective ON/OFF" or "Local remote controller prohibit/permit" One input can be selected from those above. * An external input/output adapter (PAC-YT51HAA (sold separately)) is required. Relays and DC power supply or other devices must be prepared at the site.	<input type="radio"/>	<input checked="" type="radio"/>
External output (Error output, operation output)	"ON/OFF" and "error/normal" are output with the level signal. * An external input/output adapter (PAC-YT51HAA (sold separately)) is required. Relays and DC power supply or other devices must be prepared at the site.	<input type="radio"/>	<input checked="" type="radio"/>
Checking the Gas Amount	Use this function to check for a refrigerant leak from the outdoor unit. * When this function is used, the gas amount checking function of the outdoor unit cannot be used. This function is for CITY MULTI R2 and Y (PUMY is excluded.) Series only.	<input type="checkbox"/>	<input type="checkbox"/>
Schedule operation	Weekly schedule setting of up to 12 patterns is available. In one pattern, up to 16 settings for "ON/OFF", "Operation mode", "Set Temperature", "Fan speed", "Air flow direction", and "Permit / Prohibit local operation" can be scheduled. Two types of weekly schedules (Summer/Winter) can be set. Today's schedule allows setting of up to 5 patterns.	<input type="radio"/>	<input type="radio"/>

\* Depending on the installation conditions, power supply unit (PAC-SC51KUA) is required. Please contact your local distributor or MITSUBISHI ELECTRIC branch office for further information.

# Centralized Remote Controller

ON/OFF remote controller

## PAC-YT40ANRA

Just press a switch to start. All of the units can be switched ON/OFF by pressing the main switch, and each unit in the group can be switched ON/OFF with individual switches. The PAC-YT40ANRA also has a hardwired connection available (ON/OFF input, fire alarm input, run output, fault output).



Dimensions 130(W) x 120(H) x 19(D) mm  
5-1/8(W) x 4-3/4(H) x 3/4(D) in.

### System example

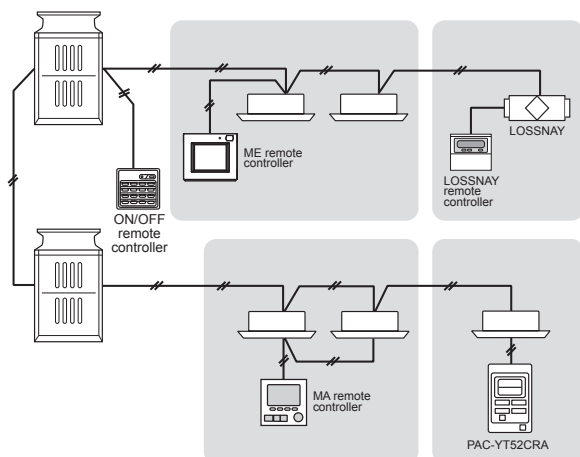

- **Control of up to 16 groups/50 indoor units is possible**
  - Up to 16 groups/50 units can be operated with one ON/OFF remote controller.
  - A general-purpose interface is available for control, allowing general devices to also be turned ON and OFF.
- **Just press a switch to start**
  - All of the units can be started and stopped by pressing the main switch, and each unit in the group can be started and stopped with individual switches.
- **LED flashing during failure**
  - If any error should occur in the air conditioner, its details can be confirmed easily with the flashing LED. The LED also indicates whether each group is running or stopped.
- **Interlock operation with external system is possible**
  - It can be flexibly interlocked with a card reader, fire alarm system, or building management system, etc., using the incorporated external input/output function.
- **Flexible group setting**
  - Groups can be easily configured, allowing the group pattern to be freely set according to the layout.
  - The ON/OFF remote controller can be connected at the indoor/outdoor transmission line without the power supply unit.

### NOTE

The dual set point function is available depending on the controller version. Please contact your local distributor regarding the availability of this function.

○: Each group □: Batch only ×: Not available

Function	Description	PAC-YT40ANRA	
		Setting	Display
UNITS	Max No.Units	50 units/16 groups	
ON/OFF	ON and OFF operation	○	○
Error indication	LED flashes during failure. (The error code can be confirmed by removing the cover.)	×	○
Ventilation operation (Independent)	Group operation of only LOSSNAY units possible. *Only ON/OFF of group.	○	○
Ventilation operation (Interlocked)	The LOSSNAY will run in interlock with the operation of the indoor unit. *The fan rate and mode cannot be changed. The LED will turn ON only during operation after interlocking.	○	○
External input	On and Off operation / Fire Alarm*	□	×
External output	On and Off operation / Faults*	×	□

\* Applicable to collective only  
Not applicable to groups

# Individual Remote Controller

Wired MA remote controller

## PAR-41MAA NEW



**Dimensions** 120(W) x 120(H) x 14.5(D) mm  
4-23/32(W) x 4-23/32(H) x 37/64(D) in.

### Highlight display

The screen background can be set to black to suit the ambience of the room.

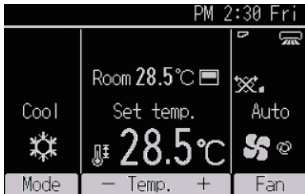

\*Factory setting : White

### More slim

Compared to the previous version (PAR-32MAA), This remote controller is slimmer by 4.5 mm (depth), allowing for more flexible installation.

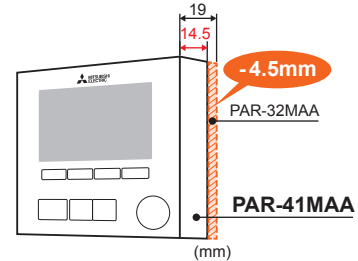

### • Backlit LCD (Liquid Crystal Display)

Large, easy-to-see display  
Full-dot LCD display with large characters for easy viewing  
Contrast also adjustable

### • Night Setback

When the room temperature goes outside of a certain range during the predetermined period, this function automatically starts heating or cooling operation to prevent dew condensation or an excessive temperature increase in the room.

### • 3D i-see sensor\*

Settings for 3D i-see sensor can be performed.

### • Draft reduction\*

"Close" has been added to the manual vane angle selection. The air outlet can be closed to reduce drafts from the air conditioner.

### • Auto descending panel\*

Panels can be lowered/raised using the remote controller. The descending distance of the panel can also be selected.

\*The availability of the function depends on the indoor unit model. For details, please contact your local distributor.

## Functions

○: Available ×: Not available

Item	Description	Setting	Display
ON/OFF	Switches between ON and OFF.	○	○
Operation mode switching	Switches between Cool / Dry / Fan / Auto / Heat.	○	○
Temperature setting	Changes the set temperature. * Set temperature range varies depending on the indoor unit model.	○	○
Air flow direction setting	Changes airflow direction. * Available airflow directions vary depending on the model.	○	○
Louver setting	Switches between louver ON/OFF.	○	○
Ventilation equipment control	Interlocked setting and interlocked operation setting with CITY MULTI LOSSNAY units can be performed. The Stop/Low/High settings of the ventilation equipment can be controlled.	○	○
Error information	When an error occurs, an error code and the unit address appear. Air conditioning unit model, serial number, and contact number can be set to appear when an error occurs. (The above information needs to be entered in advance.) * An error code may not appear depending on the error.	—	○
Timer	ON/OFF timer Turns ON and OFF daily at a set time. • Time can be set in 5-minute increments. • It is also possible to set the ON time only or the OFF time only. Auto-OFF timer Turns off the unit after a certain period of operation. • Operation time can be set to a value from 30 to 240 minutes in 10-minute increments.	○	○
Allows/disallows local operation	The following operation can be prohibited by applying certain settings on the centralized controller: ON/OFF, operation mode, temperature, filter sign reset, air direction, fan speed and timer. * While an operation is prohibited, the operation icon lights up (only on the Main display in "Full" mode).	×	○
Operation lock	The following operations can be prohibited: "Location," "ON/OFF," "Mode," "Set temp.," "Menu," "Fan," "Louver," or "Vane."	○	○
Temperature range restriction	The room temperature range for each operation mode can be restricted.	○	○
Auto return	The units operate at the preset temperature after a designated period. (Time can be set to a value from 30 to 120 minutes in 10-minute increments.) * Not valid when the temperature setting range is restricted.	○	×
Daylight saving time	The start / end time for daylight saving time can be set. The daylight saving time function will be activated based on the setting contents.	○	○



## Individual Remote Controller

Wired MA remote controller

## PAR-21MAA



Dimensions 130(W) x 120(H) x 19(D) mm  
5-1/8(W) x 4-3/4(H) x 3/4(D) in.

- Dot Liquid Crystal Display (LCD)
- Multi-language Display

- Set temperature in 1°C/°F increment

- Weekly timer

Up to 8 ON/OFF/temperature settings per day in one-minute increments. Setting kept in nonvolatile memory. No need to worry about resetting after a power failure.

- Self-diagnosis function immediately reports an error code in case of malfunction

## Example of system configuration

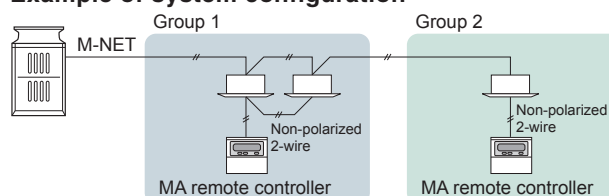

## Multi-language Display Example [Dot display table]

Language	English	German	Spanish	Russian	Italian	Chinese	French	Japanese	
Waiting for start-up	PLEASE WAIT	←	←	←	←	←	←	←	
Operation mode	Cool	COOL	Kühlen	FRÍO	Холод	COOL	制冷	FROID	冷房
	Dry	DRY	Trocknen	DESHUMIDIFICACION	Сушка	DRY	除湿	DESHU	ドライ
	Heat	HEAT	Heizen	CALOR	Тепло	HEAT	制热	CHAUD	暖房
	Auto	AUTO	AUTO	AUTO	Автомат	AUTO	自动	AUTO	自動
	Auto(Cool)	COOL	Kühlen	FRÍO	Холод	COOL	制冷	FROID	冷房
	Auto(Heat)	HEAT	Heizen	CALOR	Тепло	HEAT	制热	CHAUD	暖房
	Fan	FAN	Lüfter	VENTILACION	ВЕНТ	VENTILAZIONE	送风	VENTILATION	送風
	Ventilation	VENTILATION	Gelüftebetrieb	VENTILACION	ВЕНТИЛЯЦИЯ	ARIA ESTERNA	换气	VENTILATION	換気
Stand by (Hot adjust)	STAND BY	STAND BY	CALENTANDO	ДОГРЕВ: ПАЗА	STAND BY	准备中	PRE CHAUFFAGE	準備中	
Defrost	DEFROST	Abtauen	DESCONGELACION	ОТТАВЛИВАНИЕ	SPRINAMENTO	除霜中	DEGIVRAGE	霜取中	
Button not used	NOT AVAILABLE	Nicht verfügbar	NO DISPONIBLE	НЕ ДОСТУПНО	NON DISPONIBILE	无效按钮	NON DISPONIBILE	無効ボタン	
Check (Error)	CHECK	Prüfen	COMPROBAR	ПРОВЕРКА	CHECK	検査	CONTROLE	点検	
Test run	TEST RUN	Testbetrieb	TEST FUNCIONAMIENTO	ТЕСТОВЫЙ ЗАПУСК	TEST RUN	试运行	TEST	試運転	
Self check	SELF CHECK	Selbst-diagnose	AUTO REVISION	САМОДИАГНОСТИКА	SELF CHECK	自我诊断	AUTO CONTROLE	自己診断	
Unit function selection	FUNCTION SELECTION	Funktion auswählen	SELECCION DE FUNCION	ВЫБОР ФУНКЦИИ	SELEZIONE FUNZIONI	功能选择	SELECTION FONCTIONS	メニュー選択	
Setting of ventilation	SETTING OF VENTILATION	Lüfterstufen wählen	CONFIG. VENTILACION	НАСТРОЙКА ВЕНТИЛЯЦИИ	IMPOSTAZIONE ARIA ESTERNA	换气设定	SELECTION VENTILATION	換気設定	

## Functions

□: Each unit ○: Each group ◎: Group or collective ✕: Not available

Item	Description	Setting	Display
ON/OFF	ON and OFF operation for a single group	○	○
Operation mode switching	Switches between Cool / Dry / AUTO* / Fan / Heat. Operation modes vary depending on the air conditioner unit. * Auto only supported for the CITY MULTI R2 and WR2 Series.	○	○
Temperature setting	Changes the set temperature. * Set temperature range varies depending on the indoor unit model.	○	○
Fan speed setting	Models with 4 air flow speed settings: High/Mid-1/Mid-2/Low Models with 3 air flow speed settings: High/Mid/Low Models with 2 air flow speed settings: High/Low Fan speed setting (including Auto) varies depending on the model.	○	○
Air flow direction setting	Air flow direction angles (4-angle, or 5-angle Swing) Auto Louver ON/OFF Air flow direction settings vary depending on the model.	○	○
Permit / Prohibit local operation	Individually prohibit operation of each local remote control function (ON/OFF, Change operation mode, Set temperature, Reset filter). *1: When the local remote controller inactivation command is received from the main system controller, "E1" is displayed.	✕	○ <sup>*1</sup>
Prohibition/permission of specified mode (Cooling prohibited/heating prohibited /cooling-heating prohibited)	Operation for the following modes is prohibited through System Controller settings: At cooling prohibited: Cool, Dry, Auto, At heating prohibited: Heat, Auto, At cooling-heating prohibited: Cool, Heat, Dry, Auto	✕	○
Error	When an error is occurring on an air conditioner unit, the affected unit and the error code are displayed.	✕	□
Ventilation equipment	Up to 16 indoor units can be connected to an interlocked system that has one LOSSNAY. LOSSNAY items that can be set are "Hi" "Low" "Stop". Ventilation mode switching is not available.	○	○
Set temperature range limit	Set temperature range limit to cooling, heating, or auto mode.	○	○
Auto lock function	Setting/releasing of simplified locking for remote control switch can be performed. · Locking of all switches · Locking of all switches except ON/OFF switch	○	○

# Individual Remote Controller

ME remote controller

## PAR-U02MEDA

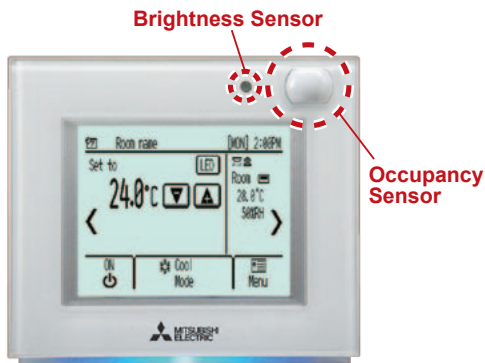

**Dimensions** 140(W) x 120(H) x 25(D) mm  
5-9/16(W) x 4-3/4(H) x 1(D) in.

### Example of system configuration

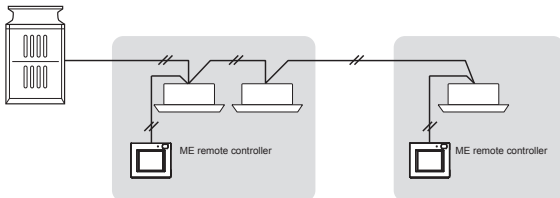

### • Occupancy Sensor

The occupancy sensor detects when the room is empty and provides energy-saving control.

### • Touch Panel & Backlit LCD

The operation settings screen is a touch panel. When the backlight is off, touching the panel turns on the backlight. The backlight will remain on for a preset length of time.

### • LED Indicator

The color of the LED indicator indicates operation status. The LED indicator is lit during normal operations, and is not lit when units are stopped. In case of error, the indicator blinks.

### • Brightness Sensor

The brightness sensor detects brightness in the room and provides energy-saving control.

### • Temperature & Humidity Sensor

The sensor detects room temperature and relative humidity.

### Occupancy Sensor detection zone

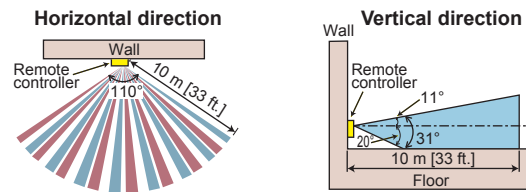

### Functions

○: Available ×: Not available

Item	Description	Setting	Display
ON/OFF	Switches between ON and OFF.	○	○
Operation mode switching	Switches between Cool / Dry / Fan / Heat / Auto. Operation modes vary depending on the indoor unit model.	○	○
Temperature setting	Changes the set temperature. * Set temperature range varies depending on the indoor unit model.	○	○
Fan speed setting	Changes fan speed. * Available fan speeds vary depending on the model.	○	○
Air flow direction setting	Changes airflow direction. * Available airflow directions vary depending on the model.	○	○
Allows/disallows local operation	The following operation can be prohibited by applying certain settings on the centralized controller: ON/OFF, operation mode setting, temperature setting, fan speed, air direction, and filter sign reset. * While an operation is prohibited, the operation icon lights up.	×	○
Error information	When an error occurs, an error code and the unit address appear. A contact number can be set to appear when an error occurs. (The information above needs to be entered in the Service menu.)	—	○
Schedule (Weekly timer)	Weekly ON/OFF times, operation mode, and set temperatures can be set. • Time can be set in 5-minute increments. Up to 8 schedule patterns can be set per day of the week. * Not valid when the ON/OFF timer is set.	○	○
Timer	ON/OFF timer Turns ON and OFF daily at a set time. • Time can be set in 5-minute increments. • It is also possible to set the ON time only or the OFF time only. Auto-OFF timer Turns off the unit after a certain period of operation. • Operation time can be set to a value from 30 to 240 in 10-minute increments.	○	○
Energy-save control during vacancy	When vacancy is detected by the occupancy sensor, the energy-save control assist function is activated. Four control types are available for selection: ON/OFF/Set temperature/Fan speed/Thermo-off. The brightness sensor can be used in conjunction with the occupancy sensor to detect the occupancy/vacancy status more accurately.	○	○



### Example of use of PAR-U02MEDA

#### Automatic turning off air conditioners

For Hotels

Mitsubishi Electric remote controller has an occupancy sensor to automatically turn off the air conditioner when the room is empty.

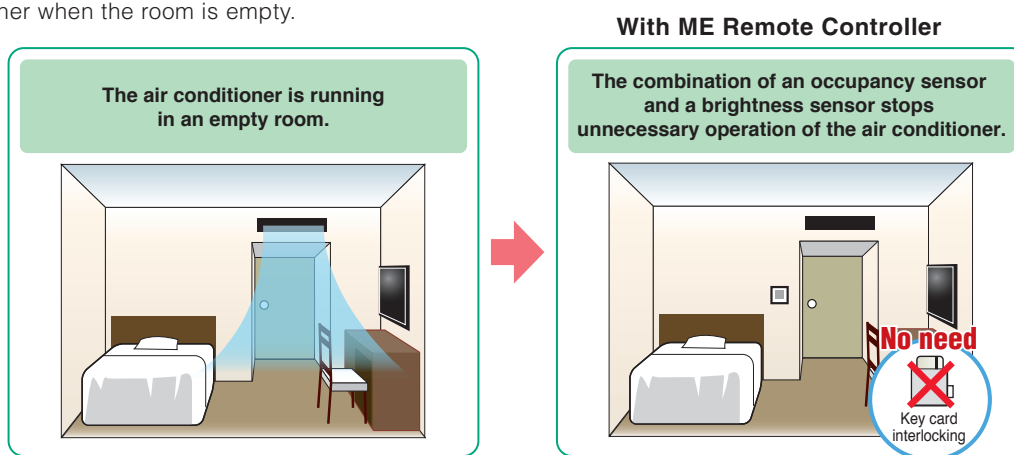

The occupancy sensor of the ME remote controller detects the conditions in the room, and the ME remote controller will automatically turn the air conditioners on or off.

For Offices

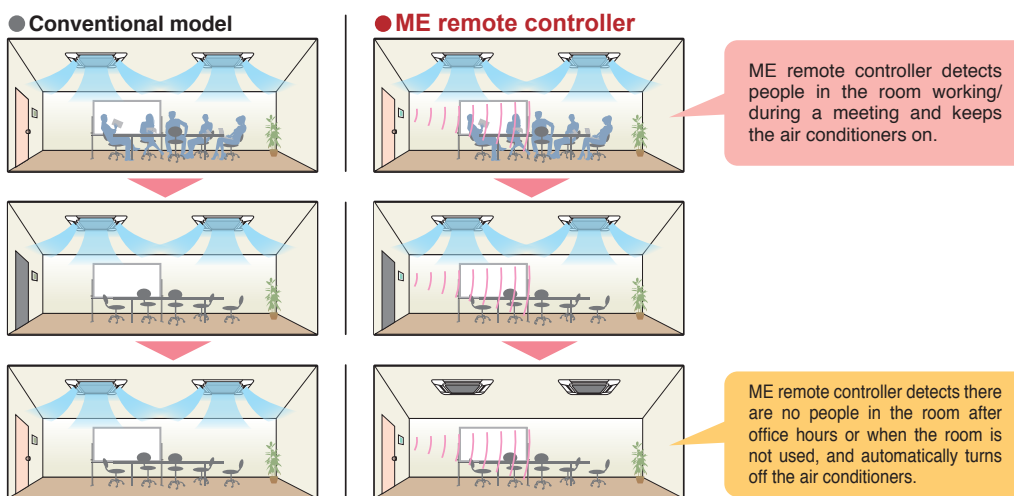

Partitioning can be installed later when a ME Remote Controller is used.

For Offices

For Commercial Facilities

● With ME Remote Controllers:

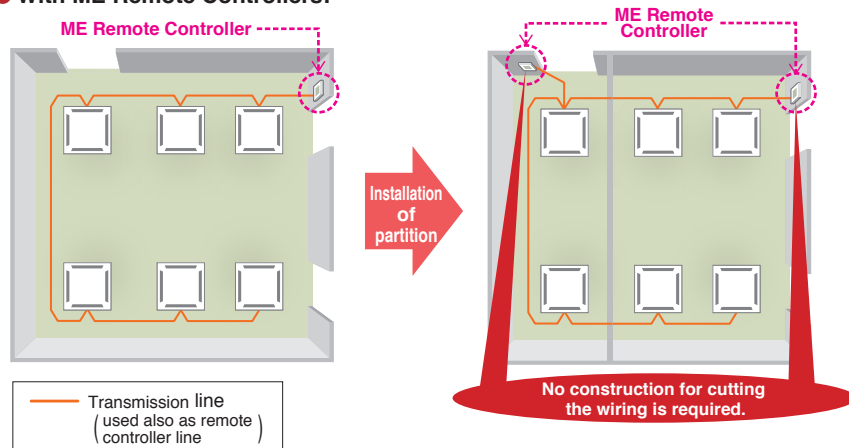

The ME remote controller can be operated when it is connected with any of the indoor units. When changing the room layout, you can set the groups easily with the remote controller.

# Individual Remote Controller

## MA remote controller PAR-CT01MAA-S



**Dimensions** 65(W) x 120(H) x 14.1(D) mm  
2-9/16(W) x 4-3/4(H) x 9/16(D) in.

### • User-friendly

Large icons are easily visible on the full color touch panel display.

### • Flexibility

Customized display, color of parameter and background, editable parameter on the initial display.

### User-friendly

Full color touch panel display



Touch Panel



3.5 inch/HVGA  
Full Color LCD

### Operation panels



Temperature setting



Operation mode



Fan speed



Vane control



Ventilation



Louver control

### Flexibility

#### Multiple color patterns

180 color patterns can be selected for the display's control parameters or background.

#### Control parameter customization

Users can customize the panel to display the selected parameters only.

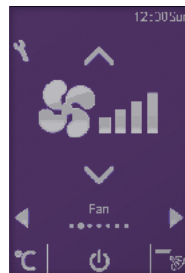

Available in a wide variety of colors to suit the decor of any room.



**System example**

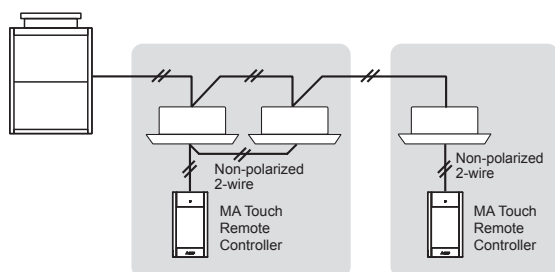

\*When a PAR-CT01MAA is connected to a group, no other MA remote controllers can be connected to the same group.

**External dimension**

Unit: mm[in.]

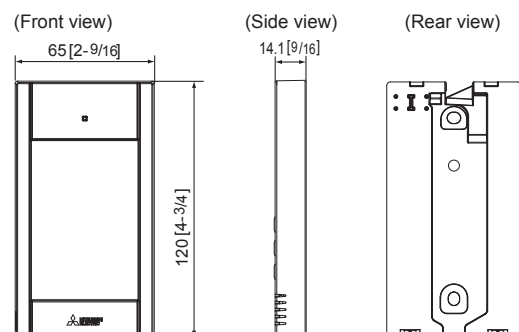

**Functions**

○: Available    ×: Not available

Item	Description	Setting	Display
ON/OFF	Switches between ON and OFF.	○	○
Operation mode switching	Switches between Cool / Dry / Fan / Auto / Heat.	○	○
Temperature setting *	Changes the set temperature. * The settable temperature range varies depending on the indoor unit model. * Temperature will be displayed either in Celsius in 0.5- or 1-degree increments, or in Fahrenheit, depending on the indoor unit model and the display mode setting on the remote controller.	○	○
Relative temperature display	Changes the target temperature by selecting the temperature difference (between +3 and +5°C or -3 and -5°C, in 1°C increments) between the preset reference temperature and the target temperature in the cool, dry, heat, or auto (single set point) mode. *The temperature can only be set to a value within the operation temperature range of the indoor unit. *When the relative temperature display is selected, certain restrictions apply to the system controller functions. *The reference temperature needs to be set to each operation mode.	○	○
Fan speed setting	Changes fan speed. * Available fan speeds vary depending on the model.	○	○
Air flow direction setting	Changes airflow direction. * Available airflow directions vary depending on the model.	○	○
Louver setting	Switches between louver ON/OFF.	○	○
Ventilation equipment control	Interlocked setting and interlocked operation setting with CITY MULTI Lossnay units can be performed. The Stop/Low/High settings of the ventilation equipment can be controlled.	○	○
Daylight saving time	The start/end time for daylight saving time can be set. The daylight saving time function will be activated based on the settings.	○	×
Error information	When an error occurs, an error code and the unit address appear. Air conditioning unit model, serial number, and contact number can be set to appear when an error occurs. (The information above needs to be entered in advance.) * An error code may not appear depending on the error.	—	○
Touch panel	The touch panel can be cleaned and calibrated.	—	○
Timer	ON/OFF timer Turns ON and OFF daily at a set time. • Time can be set in 5-minute increments. • It is also possible to set the ON time only or the OFF time only. Auto-OFF timer Turns off the unit after a certain period of operation. • Operation time can be set to a value from 30 to 240 minutes in 10-minute increments.	○	○
Allows/disallows local operation	The following operation can be prohibited by applying certain settings on the centralized controller: ON/OFF, operation mode setting, temperature setting, and filter sign reset. * While an operation is prohibited, the operation icon lights up (only on the Main display in "Full" mode).	×	○
Operation lock	The following operations can be prohibited: "Location," "ON/OFF," "mode," "Set temp.," "Menu," "Fan," "Louver," or "Vane."	○	○
Temperature range restriction	The room temperature range for each operation mode can be restricted.	○	○
Auto return	The units operate at the preset temperature after a designated period. (Time can be set to a value from 30 to 120 minutes in 10-minute increments.) * Not valid when the temperature setting range is restricted.	○	×
Design	The color of the screen can be changed.	○	○



# Individual Remote Controller

## Simple MA remote controller PAC-YT52CRA



**Dimensions** 70(W) x 120(H) x 14.5(D) mm  
2-3/4(W) x 4-3/4(H) x 19/32(D) in.

### Example of system configuration

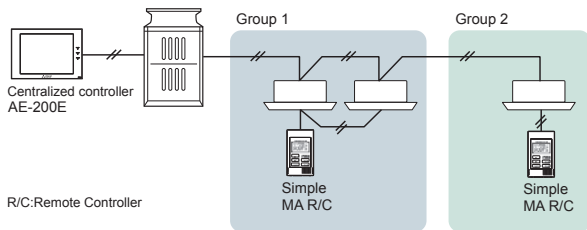

### • Backlit LCD

Backlight for operation in dark areas

### • Flat back

Slim and flat type. Hole-free installation on walls  
Less than 14.5 mm [19/32 in.] thick.

### • Vane button (standard)

A vane adjustment button has been added to allow the user to change the direction of the air flow (ceiling-cassette and wall-mounted types).

Pressing the  button will switch the vane directions.

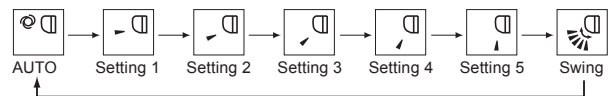

\* Air flow direction settings will vary depending on the connected indoor unit model.

\* For models without a vane adjustment function, air flow direction cannot be set. In such cases, the vane icon blinks when the  button is pressed.

### • Only cross-over wiring based on two-wire signal lines is required.

### • Room temperature sensor is built-in.

### • Can be used to operate all types of indoor units.

\*As this controller has limited functions, please use it in conjunction with the standard controller or a central controller.

### • LCD temperature settings and display are in 1°C /2°F increments.

## Functions

: Each unit    : Each group    : Not available

Item	Description	Setting	Display
ON/OFF	Switches between ON and OFF.	<input type="radio"/>	<input type="radio"/>
Operation mode switching	Switches between Cool / Dry / Fan / Heat / Auto. Operation modes vary depending on the indoor unit model.	<input type="radio"/>	<input type="radio"/>
Temperature setting	Changes the set temperature. * Set temperature range varies depending on the indoor unit model.	<input type="radio"/>	<input type="radio"/>
Fan speed setting	Changes fan speed. * Available fan speeds vary depending on the model.	<input type="radio"/>	<input type="radio"/>
Vane setting	Switches the vane directions. * The settable vane direction varies depending on the indoor unit model to be connected.	<input type="radio"/>	<input type="radio"/>
Permit / Prohibit local operation	By setting a centralized controller, the following local operations can be prohibited: ON/OFF, operation mode, preset temperature. * The CENTRAL icon appears while local operations are prohibited.	<input type="checkbox"/>	<input type="radio"/>
Error	Displays the current error status with the address. * The address may not be displayed depending on the error status.	<input type="checkbox"/>	<input type="checkbox"/>
Ventilation equipment	When the CITY MULTI indoor unit is connected, interlocked setting of the CITY MULTI LOSSNAY unit is possible. When the Mr. SLIM indoor unit (A-control) is connected, interlocked operation LOSSNAY unit (LGH-R(V) X Type) is possible.	<input type="radio"/>	<input type="radio"/>
Set temperature range limit	The preset temperature range can be restricted for each operation mode (COOL/HEAT/AUTO).	<input type="radio"/>	<input type="radio"/>

# Wireless remote controller



## PAR-FL32MA

### Dimensions

58(W) x 159(H) x 19(D) mm  
[2-5/16(W) x 6-5/16(H) x 3/4(D) in.]



## PAR-SL101A-E

(PLFY-P VEM-PA, PLFY-P VFM-E1, PKFY-P VLM-E only)

### Dimensions

66(W) x 188(H) x 22(D) mm  
[2-5/8(W) x 7-13/32(H) x 7/8(D) in.]



## PAR-FA32MA

### Dimensions

70(W) x 120(H) x 22.5(D) mm  
[2-3/4(W) x 4-3/4(H) x 7/8(D) in.]



## PAR-SE9FA-E

(PLFY-P VEM-PA signal receiver)

### Dimensions

273(H) x 29(D) mm



## PAR-SF9FA-E

(PLFY-VFM-E1 signal receiver)

### Dimensions

214(H) x 25.5(D) mm



**NEW**

## PAR-SL94B-E\*/PAR-SR2MA-E

(Wireless remote controller kit for ceiling-suspended type)  
\* PAR-SL94B-E includes transmitter.

### Dimensions

182(W) x 57(H) x 31(D) mm/  
58(W) x 159(H) x 19(D) mm  
[7-3/16(W) x 2-1/4(H) x 1-1/4(D) in.]/  
[2-5/16(W) x 6-5/16(H) x 3/4(D) in.]

- **No need to configure addresses for group operation**
- **Lit LED keeps you informed of operation - the LED also provides you with error codes via the number of blinks**
- **Can be used with the MA remote controller**  
\*When used in group configurations, wiring between indoor units is required.  
\*Combining ME remote controller and/or LOSSNAY remote controller in a group is not possible.
- **Multiple indoor units cannot be controlled from the PAR-SL101A-E**  
**Only one indoor unit can be used in each group**
- **LCD temperature setting and display in 1°C /2°F increments**

### System configuration example

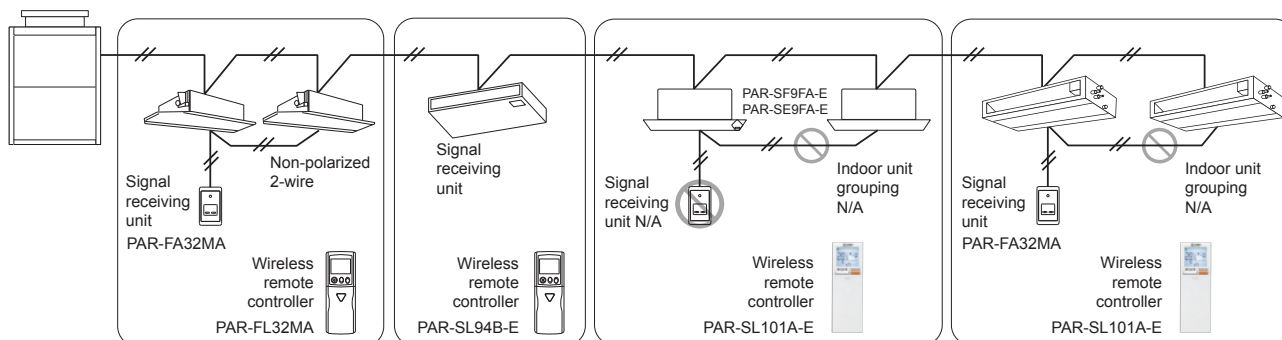

## Wireless remote controller

### Compatibility table

Indoor unit model	Receiver model	Transmitter model
PLFY-P VLMD-E	PAR-FA32MA	PAR-FL32MA
PEFY-P VMR-E-L/R		
PEFY-P VMS1(L)-E		
PEFY-P VMA(L)-E4		
PEFY-P VMA3/4-E		
PEFY-P VMH(S)-E		
PEFY-P VMH(S)-E-F		
PFFY-P VKM-E2		
PFFY-P VLEM-E		
PFFY-P VCM-E		
PMFY-P VBM-E		
PLFY-P VFM-E1	PAR-SF9FA-E	PAR-SL101A-E
PLFY-P VEM-PA	PAR-SE9FA-E	(PAR-FL32MA)*1*2
PCFY-P VKM-E	PAR-SL94B-E (PAR-SL94B-E includes a receiver and a transmitter.)	
PMFY-P VFM-PA	PAR-SR2MA-E	PAR-FL32MA
PKFY-P VKM-E	Built-in	PAR-FL32MA
PKFY-P VLM-E	Built-in	PAR-SL101A-E (PAR-FL32MA)*1*2

\*1 Use either PAR-SL101A-E or PAR-FL32MA to control each indoor unit, not both.

\*2 Multiple indoor units cannot be controlled with the PAR-SL101A-E. Only one indoor unit can be used in each group.

### Functions

○: Available ✕: Not available

Item	Description	Setting	Display
ON/OFF	ON and OFF operation for a single group	○	○
Temperature setting	Changes the set temperature. * Set temperature range varies depending on the indoor unit model.	○	○
Fan speed setting	Models with 4 air flow speed settings: Hi/Mid-1/Mid-2/Low Models with 3 air flow speed settings: Hi/Mid/Low Models with 2 air flow speed settings: Hi/Low Auto setting varies depending on the model.	○*1	○*1
Air flow direction setting	Air flow direction angles (4-angle, Swing) Auto Louver ON/OFF. Air flow direction settings vary depending on the model.	○*1	○*1
Timer operation	One ON/OFF setting can be set per day.	○	○
Permit / Prohibit local operation	Individually prohibit operation of each local remote control function (ON/OFF, Change operation mode, Set temperature, Reset filter).	✕	○*2

\*1 Some models will have a different display for the air flow direction and fan speed.

Set the air flow direction and fan speed when performing initial setting.

\*2 If operation is performed when the local remote controller inactivation command is received from the main system controller, a buzzer will sound and an LED will flash.

# Centralized Remote Controller

## PI Controller PAC-YG60MCA



**Dimensions** 200(W) x 120(H) x 45(D) mm  
7-7/8(W) x 4-3/4(H) x 1-13/16(D) in.

The PI controller counts pulses from a power meter, gas meter, water meter, and calorimeter. Combining the use of the AE-200E/AE-50E/EW-50E allows for calculating the charges for each unit and performing peak cut (e.g., demand control) operation. The meters can be monitored on the AE-200E/AE-50E LCD.

### Energy Saving Control (Peak Cut)

Enables Energy Saving Control with the use of our PI controller. (Registration of "Energy Management license pack" is required.)

**To perform energy saving, the capacity of the outdoor unit is controlled.**

\*Please note that when using an energy saving control, there are no warranties for failures, such as usage over the contracted electricity amount.

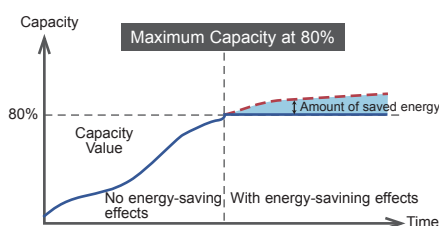

### System Structure

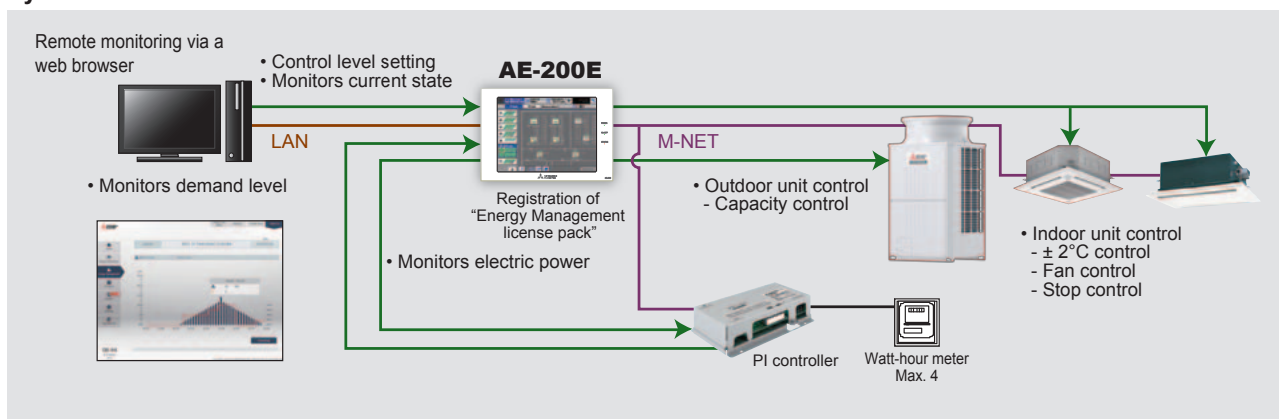

### Charge Calculation

Enables calculation of charges for each tenant and output it as a CSV file

### System Structure

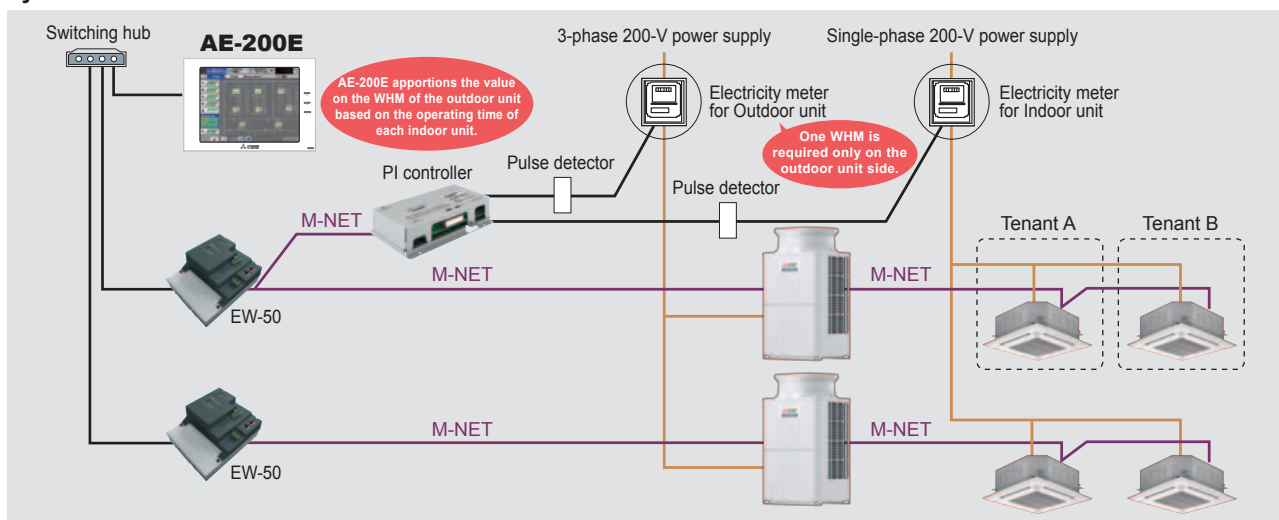

# Centralized Remote Controller

## DIDO Controller PAC-YG66DCA



Dimensions 200(W) x 120(H) x 45(D) mm  
7-7/8(W) x 4-3/4(H) x 1-13/16(D) in.

The DIDO controller is used in combination with an AE-200E/AE-50E/EW-50E to operate general-purpose equipment, as well as to monitor operating and error status. It is equipped with two sets of standard terminals (Channels 1 and 2), and four sets of expansion connectors for the input/output terminals. Expansion cable is optional.

Operation can be monitored or performed from the AE-200E/AE-50E LCD.

In addition, this device includes a function that interlocks M-NET devices such as indoor units, general equipment, etc.

### General-purpose equipment Control

Enables controlling and monitoring equipment other than air-conditioners (air-conditioners from other companies, lights, ventilators, etc.)

- In addition to above, the air-conditioners can be interlocked with general-purpose equipment.  
E.g. Interlock between indoor units and security system.
- The indoor units can be turned ON/OFF when the security system is activated/deactivated.



### System Structure

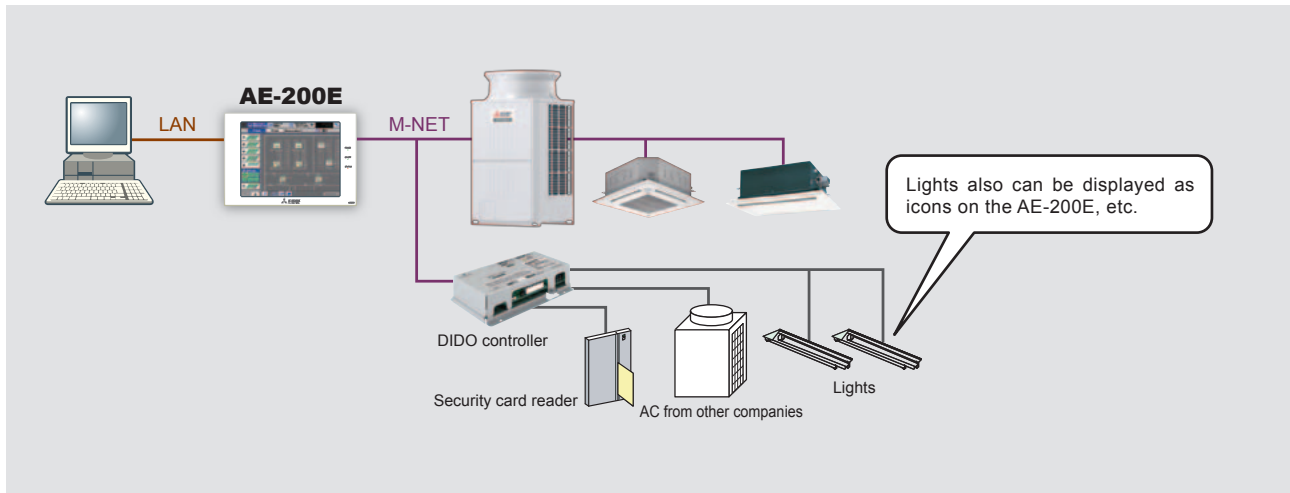



# Centralized Remote Controller

## AI Controller

# PAC-YG63MCA



**Dimensions** 200(W) x 120(H) x 45(D) mm  
7-7/8(W) x 4-3/4(H) x 1-13/16(D) in.

The AI controller measures temperature and humidity; it also has an alarm capability if the measurement data exceed defined setpoints.

Historical measurement data can be displayed only via the AE-200E/AE-50E/EW-50E web browser .

Temperature and humidity can be displayed on the AE-200E/AE-50E LCD.

Furthermore, an alarm can be output if measurement data exceeds a preset upper or lower limit.

The AI controller also features a function that interlocks M-NET devices for indoor units, etc.

## Temperature/Humidity Monitoring

Monitors the values measured by the temperature / humidity sensor connected to the AI controller

Temperature: Pt100, 4 to 20 mA DC, 1 to 5 VDC, 0 to 10 VDC

Humidity: 4 to 20 mA DC, 1 to 5 VDC, 0 to 10 VDC

- Trend displays of measurement data can be shown on a web browser.
- An alarm can be output by e-mail when measurement data exceeds a preset upper or lower limit.

## System Structure

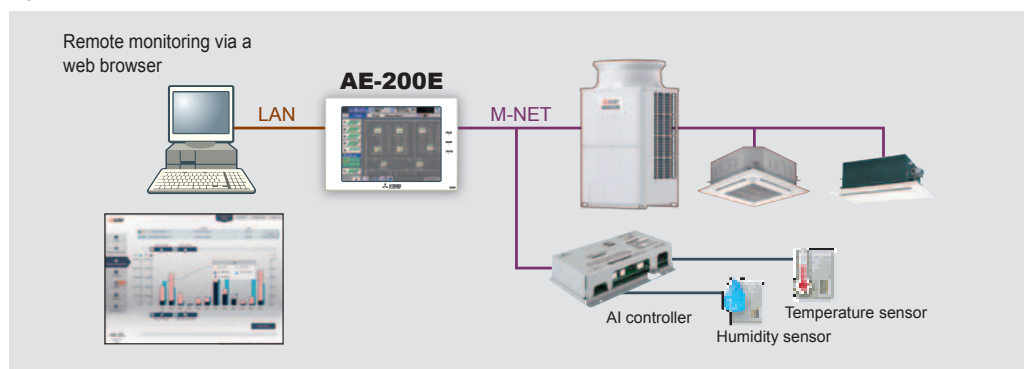

## Operation according to outside air temperature

This function controls the air conditioner's operation during the cooling/heating period to reduce the difference between the outside air temperature and the temperature in the building (near the entrance), thereby preventing stress to human health caused by rapid temperature changes. The function is effective in saving energy and can be set for each group.

The degree of change in set temperature from level 1 (1°C/2°F) to 4 (4°C/8°F) can be set for each air conditioner.

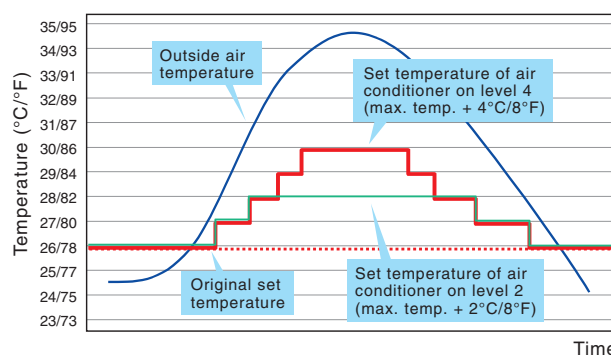

# Open network supported

The following options are available to enable connection of CITY MULTI to an open network.

## LONWORKS® (LMAP04-E)

CITY MULTI can easily combine into a Building Management System (BMS) via the LONWORKS® and M-NET adapter LMAP04-E. LONWORKS® is an opened transmission protocol widely used at BMS, and related equipment control. CITY MULTI is therefore compatible with large-scaled BMS management via LONWORKS®.



### One LM ADAPTER unit can connect up to 50 Groups/50 indoor units

Using a single LONWORKS® adapter (LM-AP), you can connect up to a maximum of 50 indoor units.

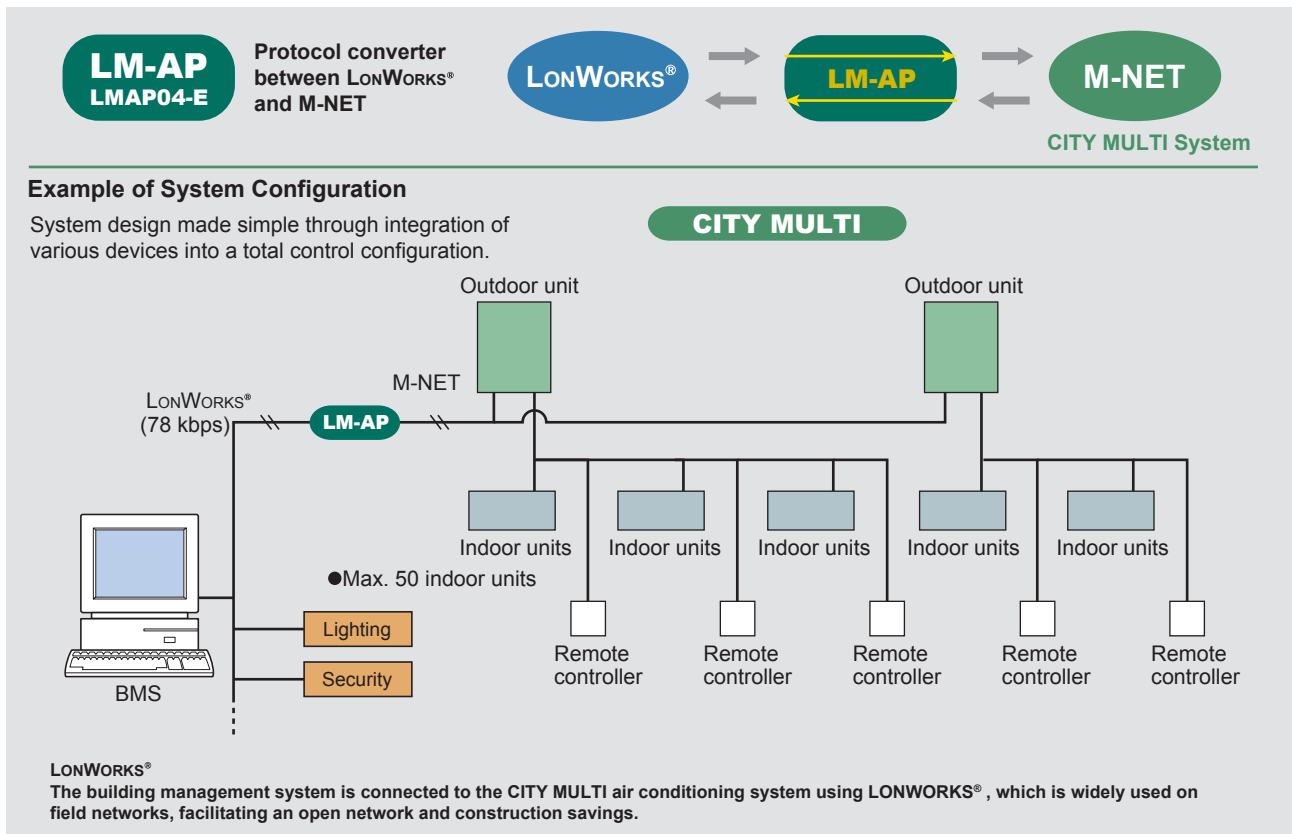

LON, LONWORKS® and the Echelon logo are trademarks of Echelon Corporation registered in the United States and other countries.

### LONWORKS® Function

FUNCTION	CONTENT
<b>Control</b>	
ON/OFF	ON / OFF
Mode Operation	Cool / Dry / Heat / Auto / Fan
Set point Adjustment	Cooling 19-35°C [67-95°F], Heating 17-28°C [63-83°F], Auto 19-28°C [67-83°F]
Fan Speed Control	High / Mid-1 / Mid-2 / Low
Permit / Prohibit	ON / OFF, Mode, Set point
Emergency Stop	-
<b>Monitoring</b>	
ON/OFF	ON / OFF
Mode	Cool / Dry / Heat / Auto / Fan
Set point	Cooling 19-35°C [67-95°F], Heating 4.5-28°C [40-83°F], Auto 19-28°C [67-83°F]
Fan Speed	High / Mid-1 / Mid-2 / Low
Permit / Prohibit	On / Off, Mode, Set point
Alarm State	Normal / Error
Room Temperature	-10-50°C (14-122°F)
Thermo ON/OFF	ON / OFF

# BACnet®

CITY MULTI can easily combine into a Building Management System (BMS) via EW-50E (AE-200E). BACnet® is an open transmission protocol widely used at BMS, and related equipment control. CITY MULTI is compatible with large-scaled BMS management via BACnet®.

Dual  
Set  
Point

## EW-50E (AE-200E) can control up to 50 units/groups (including LOSSNAY).

\*To use the BACnet® function on EW-50E (AE-200E), BACnet® license registration is required.

### System example

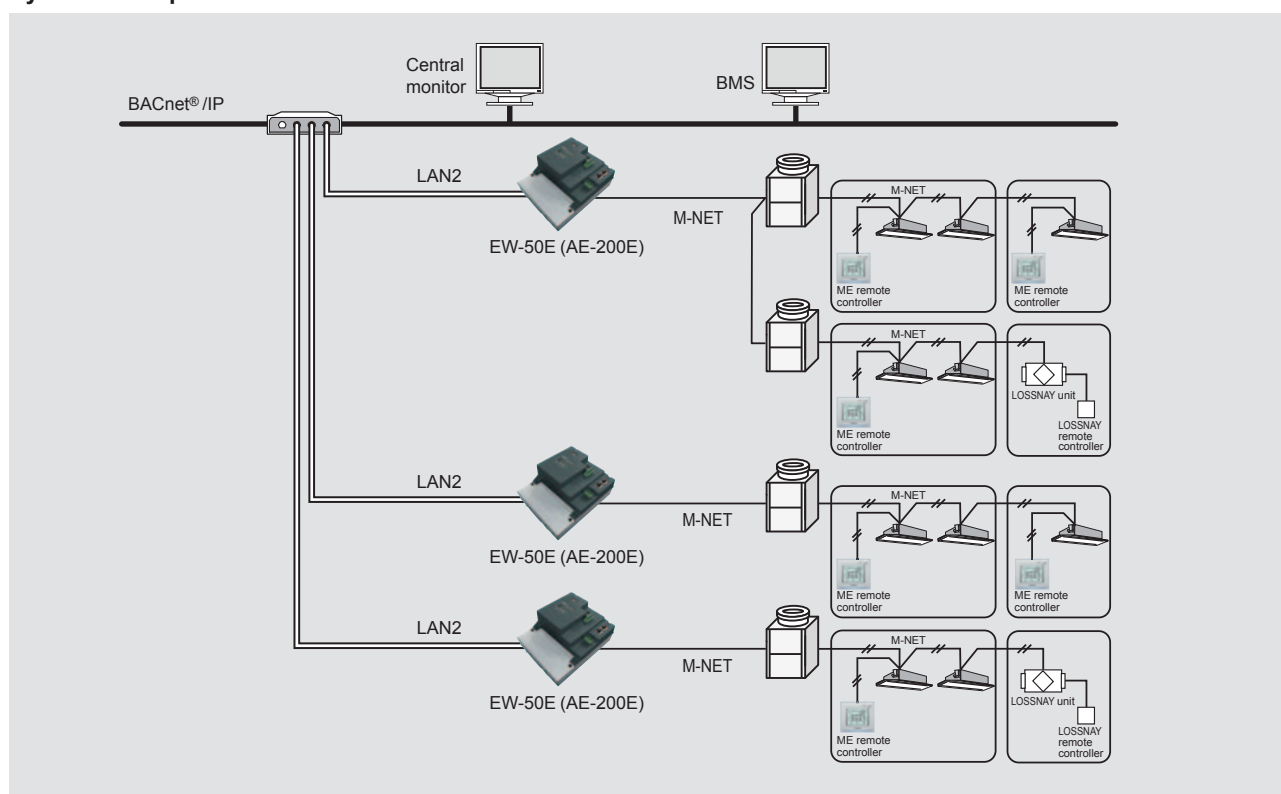

### BACnet® and M-NET Function

FUNCTION	CONTENT
<b>Operation</b>	
ON/OFF	ON/OFF
Mode	Cool/Dry/Heat/Auto/Fan
Fan Speed	Low-Mid2-Mid1-High-Auto
Air Direction	Horizontal-60%-80%-100% swing
Set Temperature	Changes the set temperature. * Set temperature range varies depending on the indoor unit model.
Filter Sign Reset	Normal/Reset
Permit/Prohibit	ON/OFF, Mode, Filter sign reset, Set temp, Fan speed
Forced Off	Reset/Execute
Ventilation Mode	Heat Recovery/Bypass/Auto
Air to Water Mode	Heating/ECO/Hot Water/Antifreeze/Cooling

FUNCTION	CONTENT
<b>Monitoring</b>	
ON/OFF	ON/OFF
Mode	Cool/Dry/Heat/Auto/Fan
Fan Speed	Low-Mid2-Mid1-High-Auto
Air Direction	Horizontal-60%-80%-100% swing
Set Temperature	Changes the set temperature. * Set temperature range varies depending on the indoor unit model.
Filter Sign	ON/OFF
Permit/Prohibit	ON/OFF, Mode, Filter sign reset, Set temp, Fan speed
Indoor Temperature	Temperature
Alarm Signal	Normal/Error
Error Code	2 Character code- Indicates all unit alarms
Error Code Detail	4 Character code- Indicates all unit alarms
Communication State	Normal/Error
Ventilation Mode	Heat Recovery/Bypass/Auto
Air to Water Mode	Heating/ECO/Hot Water/Antifreeze/Cooling
Apportioned Electric Energy	Group, Interlocked Units 0.1 kWh
PI controller Electric Energy	0.1 kWh
Apportionment Parameter	Available*
Night Purge State	ON/OFF
Thermo On/Off State	ON/OFF
External Heat Source State	ON/OFF
Trend Log	Indoor Temp, Apportioned Electric Energy, PI controller Electric Energy, Apportionment Parameter

\* To use this function, the license to charge, AE-200E (not connected to the M-NET), PI controller, watt-hour meter with pulse transmitter (locally available one) are required.

# LOSSNAY

## Indoor air quality inside a building is optimised through temperature and humidity exchange by Lossnay

Lossnay is a total heat exchange ventilation system that uses paper characteristics to perform temperature (sensible heat) and humidity (latent heat) exchange.

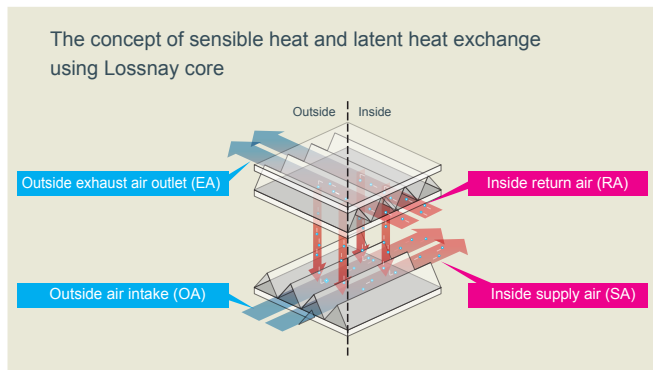
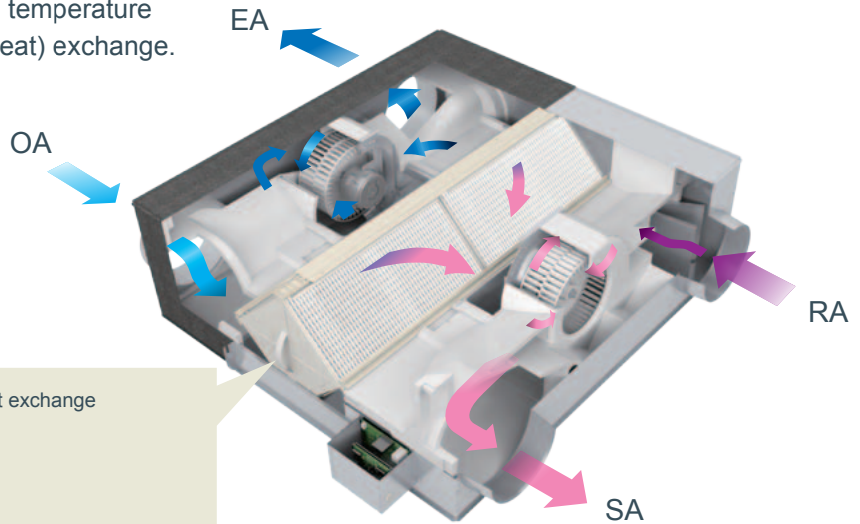

## The need for ventilation

### ■ The need for fresh air

Poor air quality can be attributed to many problems arising in the workplace and in the home. It is believed to contribute to a significant loss in productivity, low morale and higher rates of sickness. Providing good ventilation in residential and commercial buildings is to provide conditions under which people can live and work comfortably and safely.

### Effect of oxygen deficiency on human body

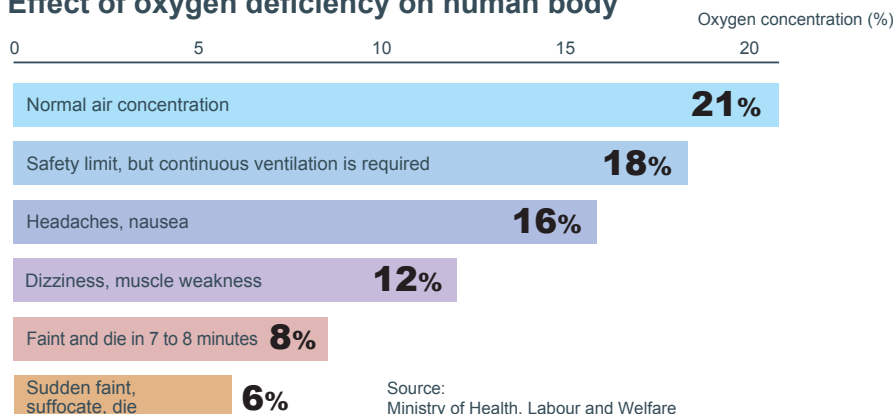

## Lossnay realize more comfortable amenities

The filter equipped on Lossnay core eliminates dust and dirt from outside. It provides clean and fresh outdoor air to your rooms. And, supply fan and exhaust fan runs to ensure that the indoor air pressure is well-balanced. It prevents draft from outside, too.

### Conventional ventilation system

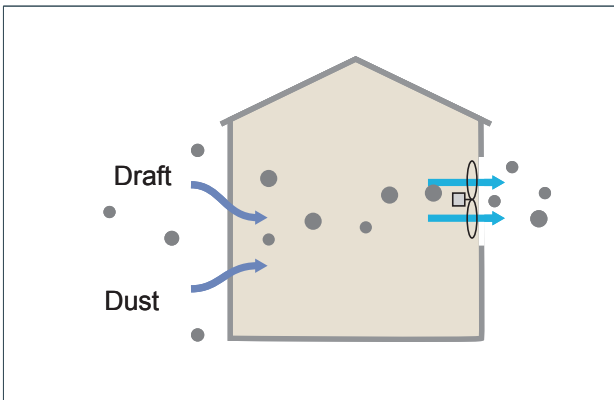

### Lossnay ventilation system

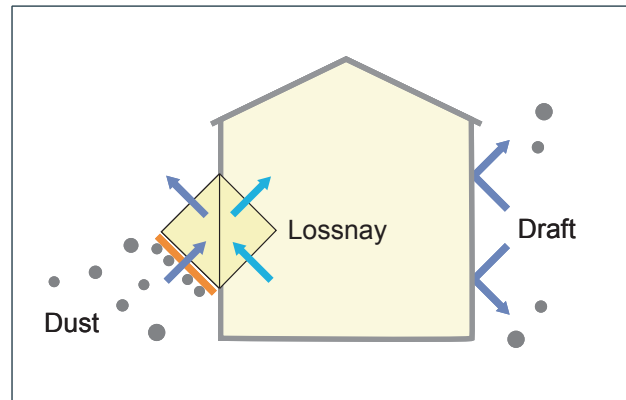

## What can be improved by introducing Lossnay?

### Ventilation with maximised comfort

**In summer**

Air similar to the conditions of the cooled (dehumidified) indoor air is supplied.

	LOSSNAY	Conventional ventilator
Dry bulb temperature (°C)	28	33
Absolute humidity (g/kg(DA))	13.3	20.1
Relative humidity (%)	56	63
Enthalpy (kJ/kg(DA))	62.1	84.6
Total energy recovery (kW)	7.5	0
Outdoor air load (kW)	3.1	10.6
Outdoor air load ratio (%)	29	100

Room air	
Dry bulb temperature	26°C
Absolute humidity	10.5g/kg(DA)
Relative humidity	50%
Enthalpy	52.9kJ/kg(DA)

Outdoor air	
Dry bulb temperature	33°C
Absolute humidity	20.1g/kg(DA)
Relative humidity	63%
Enthalpy	84.6kJ/kg(DA)

**Heat recovery calculation**

$$\text{Indoor supply-air temperature (°C)} = \text{Outdoor temperature (°C)} - \left\{ \text{Outdoor temperature (°C)} - \text{Indoor temperature (°C)} \right\} \times \text{Temp recovery efficiency (\%)}$$

Calculation example :  $28^{\circ}\text{C} = 33^{\circ}\text{C} - (33^{\circ}\text{C} - 26^{\circ}\text{C}) \times 71.5\%$

\*The above applies to the case of LGH-100RVX (fan speed 4).



## Further Energy Saving Features

### ■ Night purge

During the summer season, the Night Purge mode draws cooler outside air into the room at night. This energy conservation mode reduces the load when the air conditioning is started up the next morning. With previous models, the unit is operated with only one condition that is set initially. With RVX models, it is possible to freely set\* the night purge operation for the start conditions, airflow, and operation time and flexibly answer to the operating environment requests that vary with each customer.

\* Settings can only be made using the PZ-61DR-E

#### Previous model

Night purge function operation time

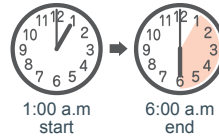

#### Start condition

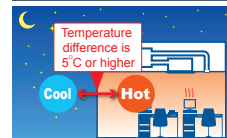

#### Fan speed

Start the operation at the same fan speed before stopping



#### RVX model

Operating time	Start condition (inside-outside temperature difference)	Fan speed
Possible to set to any time	Can be set to between 0°C and 7°C (1°C increments)	Select from Fan Speed 1 to 4

## Improved Controllability

### ■ Improved Airflow Range

#### Wide airflow range

Each fan speed has a range setting of 25, 50, 75 and 100%, to allow much finer airflow control. When used in combination with the CO<sub>2</sub> sensor or timer function, airflow can be controlled even more precisely to realize better performance and reduce power consumption.

#### Fan speed adjustment

The default fan speed values can be minutely adjusted. Use the PZ-61DR-E remote controller to set the speed as desired.

- 1) Considering the total hours of Lossnay operation (filter clogging), fan power can be adjusted automatically after a given period of time.
- 2) After the unit is installed, fine adjustments may be made if the airflow is slightly lower than the desired airflow.

Characteristic curves of the LGH-RVX Series

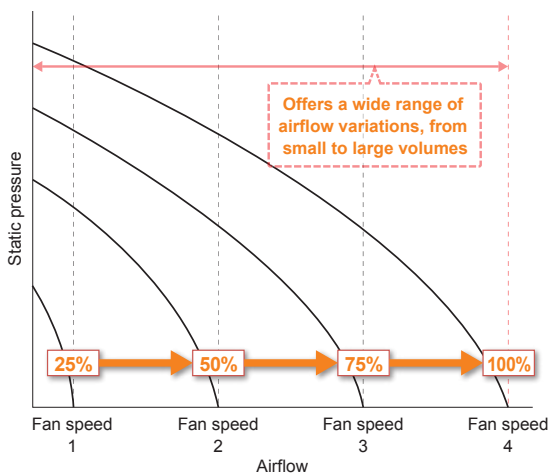

P-Q curve image

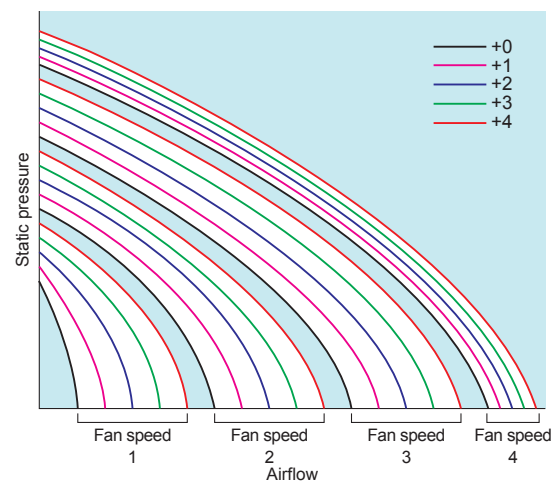

### ■ Airflow control by CO<sub>2</sub> sensor

An external CO<sub>2</sub> sensor can be connected directly to the Lossnay RVX units allowing the fan speed to vary according to the CO<sub>2</sub> levels detected.

When the CO<sub>2</sub> concentration is low, the unit can operate at a lower airflow compared to previous models and this improves total heat exchange efficiency and contributes to energy saving.

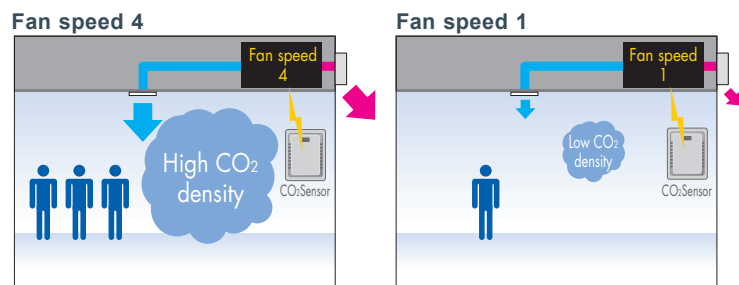

## Improved control with BMS

Using a 0-10V signal from the building management system, the airflow of the Lossnay unit can be changed.

Connection example : BMS (Building Management System)

Input voltage [VDC]	Fan speed	Fan speed changing from remote controller
0 - 1.0	-	Available
1.5 - 2.5	1	Not available
3.5 - 4.5	2	Not available
5.5 - 7.0	3	Not available
8.5 - 10.0	4	Not available

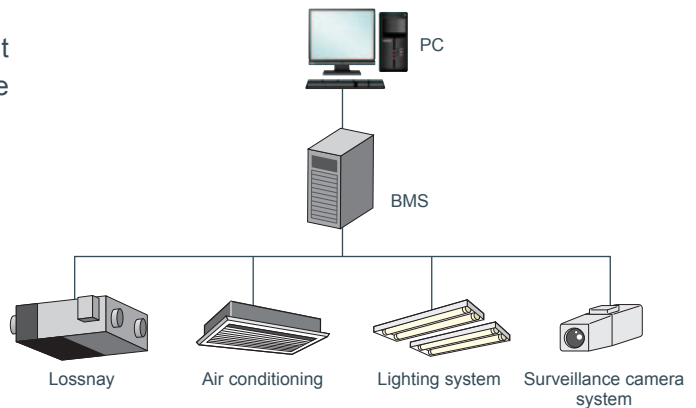

## Connect ducts in two different directions (OA, EA side)

Ducts can be connected in two different directions to the outdoor vents thanks to collars and aperture plates that can be interchangeably placed in two different positions. This flexibility allows for installations close to the surface of a wall and helps avoid cases where the stale air exhaust vent would be blocked by an obstruction of some kind. This makes both planning and installation that much simpler.

Standard installation	Installation with duct direction changed
<p>A space is necessary to prevent the influx of rainwater.</p> <p>EA ↓    ↑ OA</p>	<p>Can be installed close to the surface of the wall.</p> <p>EA ↓    ↑ OA</p> <p>Avoid installations where the stale air exhaust aperture would be blocked by lighting or air conditioning units.</p> <p>EA ↓    ↑ OA</p>
<p>Flange    Plate</p>	<p>Exchangeable</p> <p>Remove the flange (factory-standard direction) and the side panel plate and switch their placements. They are both equipped with screw stoppers making the switch extremely simple. The direction of the ducts can only be changed on the outside (OA and EA). The inside cannot be changed (SA and RA).</p>

# Solution to PM2.5

## Why do you need a filter in your ventilation system?

Ventilation is important. However, outside air may not always be fresh and clean, especially if you are living in a smog-choked city. Filtering the outside air before bringing it into your home/office is a solution to reduce your exposure to air pollution.

## What is PM2.5?

PM2.5 is airborne particulates that are 2.5 µm or smaller in size. They may carry toxins in the air and can penetrate deep into the lungs, potentially causing health problems.

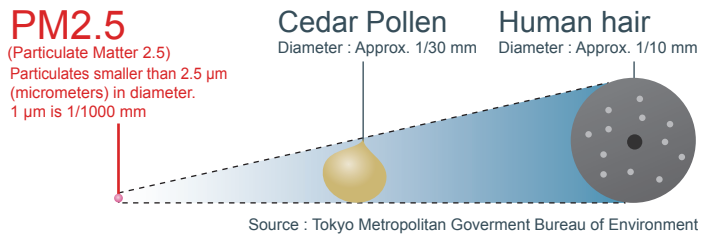

## Collects 99.7% of particles larger than 0.5µm

The new optional filter (PZ-RFP<sub>2</sub>-E series) removes 99.7%\* of particles larger than 0.5 µm. By removing the pollutants, fresh and clean air is supplied.

\*GB/T14295-2008 : YG class, 99.7% (Collecting efficiency for particles that are 0.5 µm or larger)  
\*PM2.5 is airborne particulates that are 2.5 µm or smaller in size.  
\*The collecting performance of airborne particulates smaller than 0.3 µm cannot be confirmed.

Collecting performance of an optional advanced high-efficiency filter

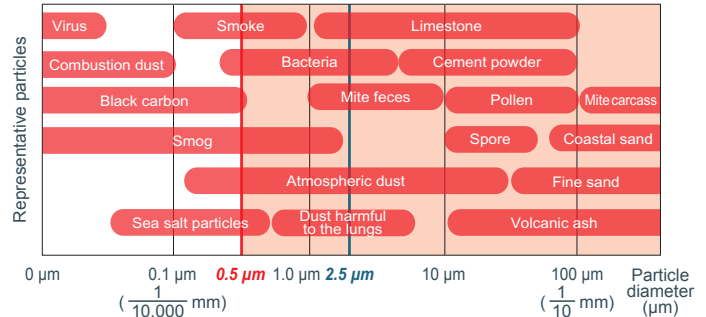

Advantages of CITY MULTI

Outdoor/Heat source unit

Indoor unit

Remote Controller

Lossnay

Installation information

# Control

## The Remote Controller PZ-61DR-E enables simple control setting

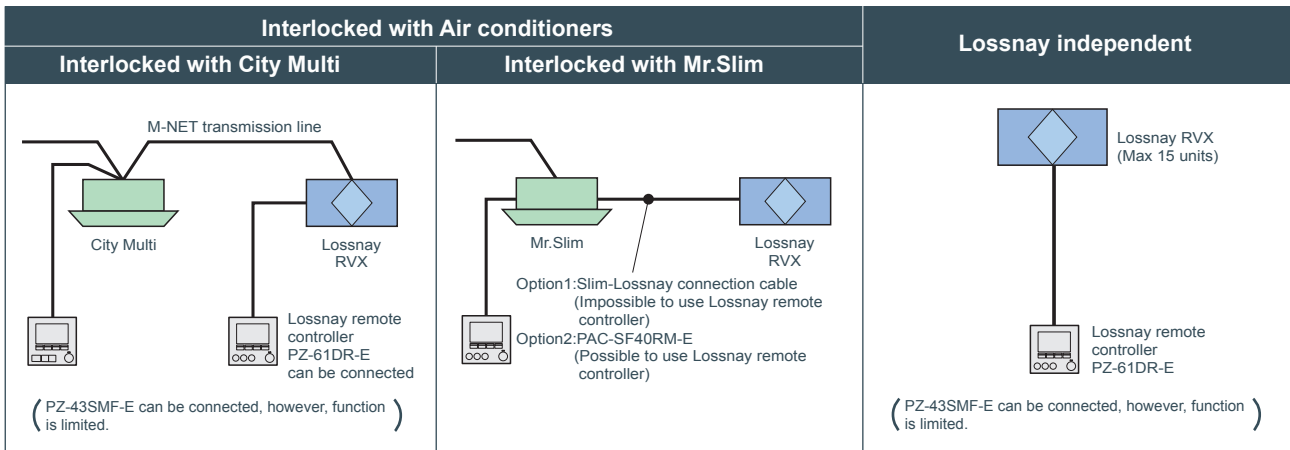

## Centralised Controller System

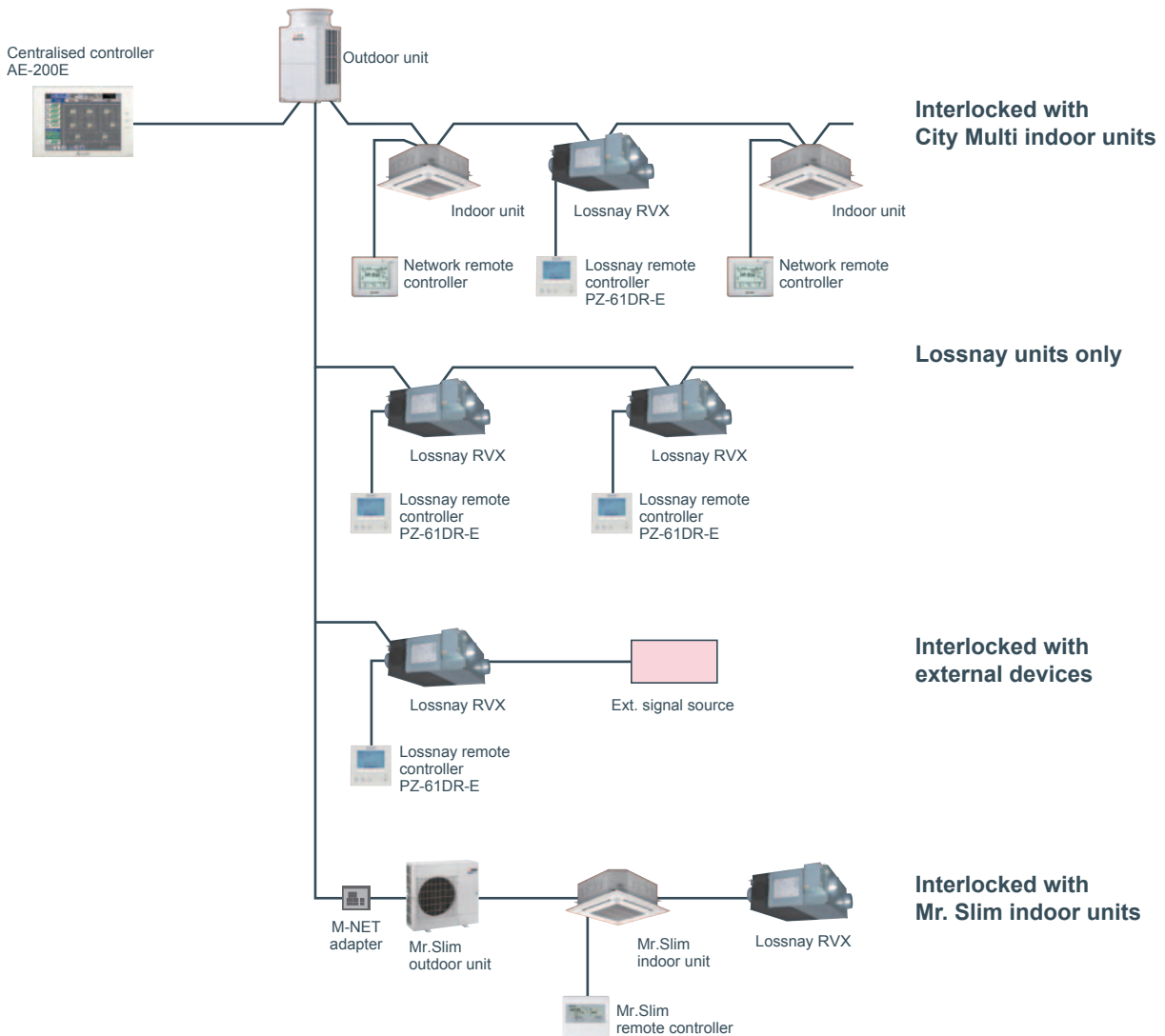





Advantages of CITY MULTI

Outdoor/Heat source unit

Indoor unit

Remote Controller

Lossnay

Installation information

Model		LGH-15RVX-E							
Electrical power supply		220-240V/50Hz, 220V/60Hz							
Ventilation mode		Heat recovery mode				Bypass mode			
Fan speed		SP4	SP3	SP2	SP1	SP4	SP3	SP2	SP1
Running current (A)		0.40	0.24	0.15	0.10	0.41	0.25	0.15	0.10
Input power (W)		49	28	14	7	52	28	14	8
Airflow	(m <sup>3</sup> /h)	150	113	75	38	150	113	75	38
	(L/s)	42	31	21	10	42	31	21	10
External static pressure (Pa)		95	54	24	6	95	54	24	6
Temperature exchange efficiency (%)	Heating	80.0	81.0	83.0	84.0	—	—	—	—
	Cooling	72.0	75.0	80.0	84.0	—	—	—	—
Enthalpy exchange efficiency (%)	Heating	73.0	75.5	78.0	79.0	—	—	—	—
	Cooling	71.0	74.5	78.0	79.0	—	—	—	—
Noise (dB) (Measured at 1.5m under the center of unit in an anechoic chamber)		28.0	24.0	19.0	17.0	29.0	24.0	19.0	18.0
Weight (kg)		20							

\*The Air outlets noise (45° angle, 1.5meters in front of the unit) is about 13dB greater than the indicated value. (at Fan speed 4)  
 \*The running current, the input power, the efficiency and the noise are based on the rating airflow, and 230V/50Hz, 220V/60Hz.  
 \*For the specification at the other frequency contact your dealer.

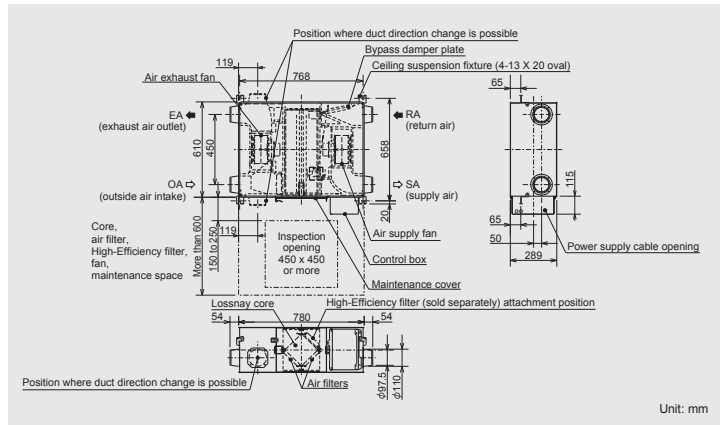
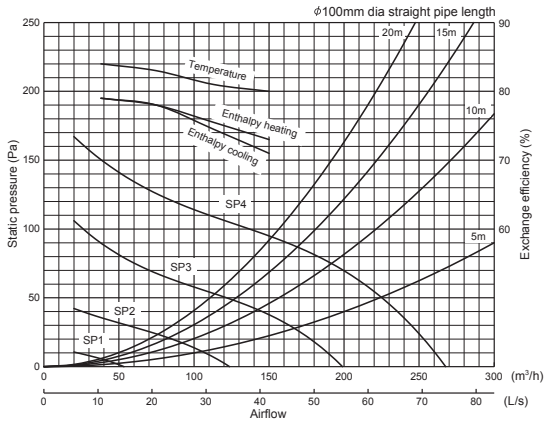

Model		LGH-25RVX-E							
Electrical power supply		220-240V/50Hz, 220V/60Hz							
Ventilation mode		Heat recovery mode				Bypass mode			
Fan speed		SP4	SP3	SP2	SP1	SP4	SP3	SP2	SP1
Running current (A)		0.48	0.28	0.16	0.10	0.48	0.29	0.16	0.11
Input power (W)		62	33	16	7.5	63	35	17	9
Airflow	(m <sup>3</sup> /h)	250	188	125	63	250	188	125	63
	(L/s)	69	52	35	17	69	52	35	17
External static pressure (Pa)		85	48	21	5	85	48	21	5
Temperature exchange efficiency (%)	Heating	79.0	80.0	82.0	86.0	—	—	—	—
	Cooling	73.0	78.5	82.0	86.0	—	—	—	—
Enthalpy exchange efficiency (%)	Heating	69.5	72.0	76.0	83.0	—	—	—	—
	Cooling	68.0	70.0	74.5	83.0	—	—	—	—
Noise (dB) (Measured at 1.5m under the center of unit in an anechoic chamber)		27.0	22.0	20.0	17.0	27.5	23.0	20.0	17.0
Weight (kg)		23							

\*The Air outlets noise (45° angle, 1.5meters in front of the unit) is about 15dB greater than the indicated value. (at Fan speed 4)  
 \*The running current, the input power, the efficiency and the noise are based on the rating airflow, and 230V/50Hz, 220V/60Hz.  
 \*For the specification at the other frequency contact your dealer.

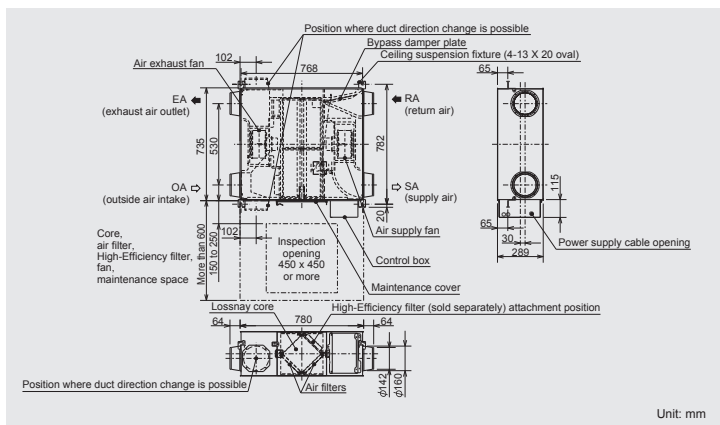
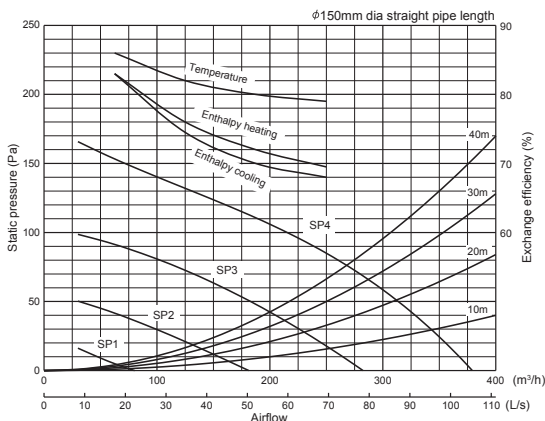



Model		LGH-35RVX-E							
Electrical power supply		220-240V/50Hz, 220V/60Hz							
Ventilation mode		Heat recovery mode				Bypass mode			
Fan speed		SP4	SP3	SP2	SP1	SP4	SP3	SP2	SP1
Running current (A)		0.98	0.54	0.26	0.12	0.98	0.56	0.28	0.13
Input power (W)		140	70	31	11	145	72	35	13
Airflow	(m <sup>3</sup> /h)	350	263	175	88	350	263	175	88
	(L/s)	97	73	49	24	97	73	49	24
External static pressure (Pa)		160	90	40	10	160	90	40	10
Temperature exchange efficiency (%)	Heating	80.0	82.5	86.0	88.5	—	—	—	—
	Cooling	72.5	78.0	84.5	87.0	—	—	—	—
Enthalpy exchange efficiency (%)	Heating	71.5	74.0	78.5	83.5	—	—	—	—
	Cooling	71.0	73.0	78.0	82.0	—	—	—	—
Noise (dB) (Measured at 1.5m under the center of unit in an anechoic chamber)		32.0	28.0	20.0	17.0	32.5	28.0	20.0	18.0
Weight (kg)		30							

\*The Air outlets noise (45° angle, 1.5meters in front of the unit) is about 12dB greater than the indicated value.(at Fan speed 4)

\*The running current, the input power, the efficiency and the noise are based on the rating airflow, and 230V/50Hz, 220V/60Hz.

\*For the specification at the other frequency contact your dealer.

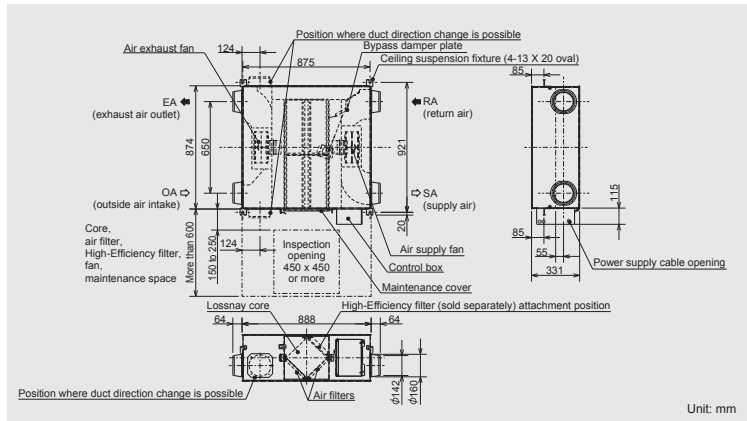
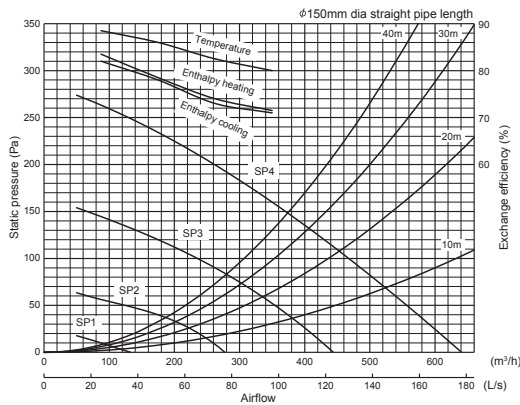

Model		LGH-50RVX-E							
Electrical power supply		220-240V/50Hz, 220V/60Hz							
Ventilation mode		Heat recovery mode				Bypass mode			
Fan speed		SP4	SP3	SP2	SP1	SP4	SP3	SP2	SP1
Running current (A)		1.15	0.59	0.26	0.13	1.15	0.59	0.27	0.13
Input power (W)		165	78	32	12	173	81	35	14
Airflow	(m <sup>3</sup> /h)	500	375	250	125	500	375	250	125
	(L/s)	139	104	69	35	139	104	69	35
External static pressure (Pa)		120	68	30	8	120	68	30	8
Temperature exchange efficiency (%)	Heating	78.0	81.0	83.5	87.0	—	—	—	—
	Cooling	70.5	75.5	79.0	87.0	—	—	—	—
Enthalpy exchange efficiency (%)	Heating	69.0	71.0	75.0	82.5	—	—	—	—
	Cooling	66.5	68.0	72.5	82.0	—	—	—	—
Noise (dB) (Measured at 1.5m under the center of unit in an anechoic chamber)		34.0	28.0	19.0	18.0	35.0	29.0	20.0	18.0
Weight (kg)		33							

\*The Air outlets noise (45° angle, 1.5meters in front of the unit) is about 18dB greater than the indicated value.(at Fan speed 4)

\*The running current, the input power, the efficiency and the noise are based on the rating airflow, and 230V/50Hz, 220V/60Hz.

\*For the specification at the other frequency contact your dealer.

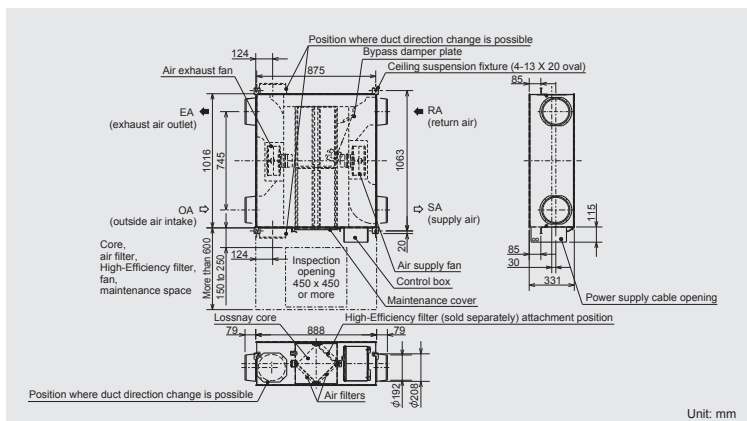
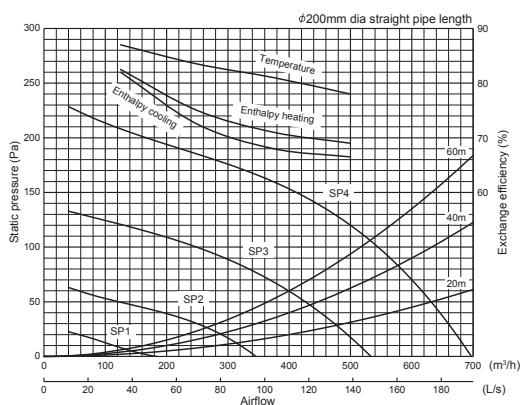



Advantages of CITY MULTI

Outdoor/Heat source unit

Indoor unit

Remote Controller

Lossnay

Installation information

Model		LGH-65RVX-E							
Electrical power supply		220-240V/50Hz, 220V/60Hz							
Ventilation mode		Heat recovery mode				Bypass mode			
Fan speed		SP4	SP3	SP2	SP1	SP4	SP3	SP2	SP1
Running current (A)		1.65	0.90	0.39	0.15	1.72	0.86	0.38	0.16
Input power (W)		252	131	49	15	262	131	47	17
Airflow	(m <sup>3</sup> /h)	650	488	325	163	650	488	325	163
	(L/s)	181	135	90	45	181	135	90	45
External static pressure (Pa)		120	68	30	8	120	68	30	8
Temperature exchange efficiency (%)	Heating	77.0	81.0	84.0	86.0	—	—	—	—
	Cooling	69.0	73.5	80.5	86.0	—	—	—	—
Enthalpy exchange efficiency (%)	Heating	68.5	71.0	76.0	82.0	—	—	—	—
	Cooling	66.0	69.5	74.0	81.0	—	—	—	—
Noise (dB) (Measured at 1.5m under the center of unit in an anechoic chamber)		34.5	29.0	22.0	18.0	35.5	29.0	22.0	18.0
Weight (kg)		38							

\*The Air outlets noise (45° angle, 1.5meters in front of the unit) is about 16dB greater than the indicated value.(at Fan speed 4)  
 \*The running current, the input power, the efficiency and the noise are based on the rating airflow, and 230V/50Hz, 220V/60Hz.  
 \*For the specification at the other frequency contact your dealer.

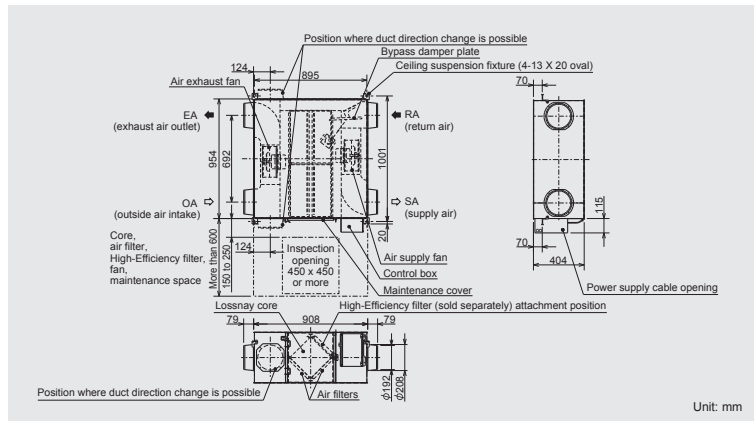
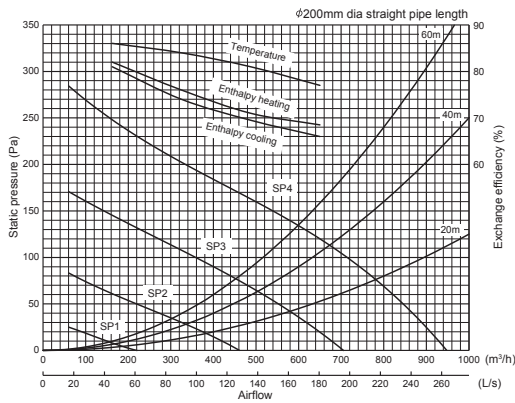

Model		LGH-80RVX-E							
Electrical power supply		220-240V/50Hz, 220V/60Hz							
Ventilation mode		Heat recovery mode				Bypass mode			
Fan speed		SP4	SP3	SP2	SP1	SP4	SP3	SP2	SP1
Running current (A)		1.82	0.83	0.36	0.15	1.97	0.86	0.40	0.15
Input power (W)		335	151	60	18	340	151	64	20
Airflow	(m <sup>3</sup> /h)	800	600	400	200	800	600	400	200
	(L/s)	222	167	111	56	222	167	111	56
External static pressure (Pa)		150	85	38	10	150	85	38	10
Temperature exchange efficiency (%)	Heating	79.0	82.5	84.0	85.0	—	—	—	—
	Cooling	71.5	78.0	83.0	85.0	—	—	—	—
Enthalpy exchange efficiency (%)	Heating	71.0	73.5	78.0	81.0	—	—	—	—
	Cooling	70.0	72.5	78.0	81.0	—	—	—	—
Noise (dB) (Measured at 1.5m under the center of unit in an anechoic chamber)		34.5	30.0	23.0	18.0	36.0	30.0	23.0	18.0
Weight (kg)		48							

\*The Air outlets noise (45° angle, 1.5meters in front of the unit) is about 24dB greater than the indicated value.(at Fan speed 4)  
 \*The running current, the input power, the efficiency and the noise are based on the rating airflow, and 230V/50Hz, 220V/60Hz.  
 \*For the specification at the other frequency contact your dealer.  
 \*Use this unit with static pressure 240Pa or less at Fan speed4. Otherwise the noise level might be larger.

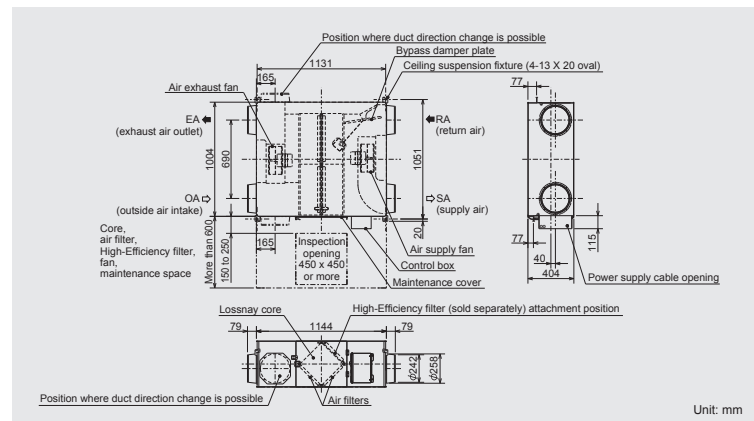
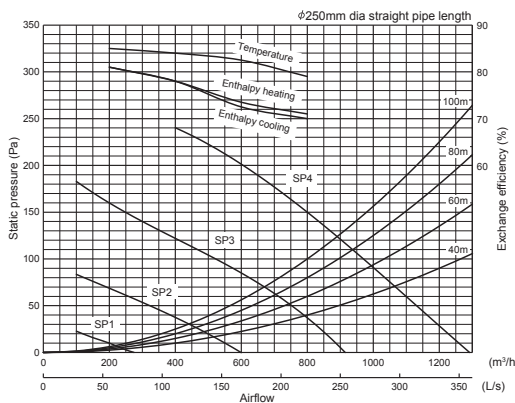



Model		LGH-100RVX-E							
Electrical power supply		220-240V/50Hz, 220V/60Hz							
Ventilation mode		Heat recovery mode				Bypass mode			
Fan speed		SP4	SP3	SP2	SP1	SP4	SP3	SP2	SP1
Running current (A)		2.50	1.20	0.50	0.17	2.50	1.20	0.51	0.19
Input power (W)		420	200	75	21	420	200	75	23
Airflow	(m <sup>3</sup> /h)	1000	750	500	250	1000	750	500	250
	(L/s)	278	208	139	69	278	208	139	69
External static pressure (Pa)		170	96	43	11	170	96	43	11
Temperature exchange efficiency (%)	Heating	80.0	83.0	86.5	89.5	—	—	—	—
	Cooling	71.5	78.0	85.0	89.5	—	—	—	—
Enthalpy exchange efficiency (%)	Heating	72.5	74.0	78.0	87.0	—	—	—	—
	Cooling	71.0	73.0	77.0	85.5	—	—	—	—
Noise (dB) (Measured at 1.5m under the center of unit in an anechoic chamber)		37.0	31.0	23.0	18.0	38.0	32.0	24.0	18.0
Weight (kg)		54							

\*The Air outlets noise (45° angle, 1.5meters in front of the unit) is about 21dB greater than the indicated value.(at Fan speed 4)

\*The running current, the input power, the efficiency and the noise are based on the rating airflow, and 230V/50Hz, 220V/60Hz.

\*For the specification at the other frequency contact your dealer.

\*Use this unit between static pressure 60Pa and 240Pa at Fan speed4. Otherwise the motor protection may work and reduce its output or the noise level might be larger.

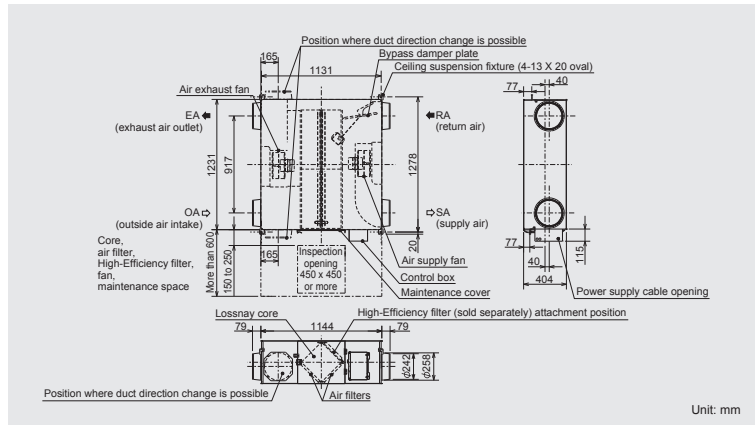
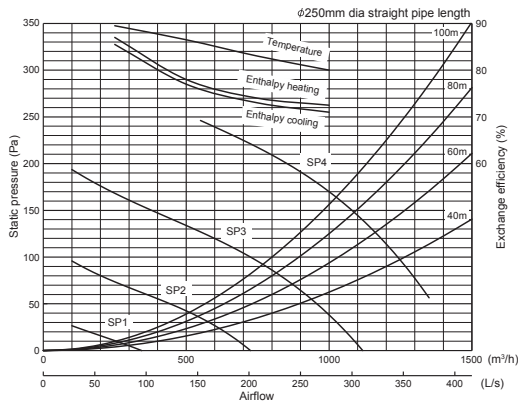



Advantages of CITY MULTI

Outdoor/Heat source unit

Indoor unit

Remote Controller

Lossnay

Installation information

Model		LGH-150RVX-E							
Electrical power supply		220-240V/50Hz, 220V/60Hz							
Ventilation mode		Heat recovery mode				Bypass mode			
Fan speed		SP4	SP3	SP2	SP1	SP4	SP3	SP2	SP1
Running current (A)		3.71	1.75	0.70	0.29	3.85	1.78	0.78	0.30
Input power (W)		670	311	123	38	698	311	124	44
Airflow	(m³/h)	1500	1125	750	375	1500	1125	750	375
	(L/s)	417	313	208	104	417	313	208	104
External static pressure (Pa)		175	98	44	11	175	98	44	11
Temperature exchange efficiency (%)	Heating	80.0	82.5	84.0	85.0	—	—	—	—
	Cooling	71.5	78.0	83.0	85.0	—	—	—	—
Enthalpy exchange efficiency (%)	Heating	72.0	73.5	78.0	81.0	—	—	—	—
	Cooling	70.5	72.5	78.0	81.0	—	—	—	—
Noise (dB) (Measured at 1.5m under the center of unit in an anechoic chamber)		39.0	32.0	24.0	18.0	40.5	33.0	26.0	18.0
Weight (kg)		98							

- \*The Air outlets noise (45° angle, 1.5meters in front of the unit) is about 22dB greater than the indicated value.(at Fan speed 4)
- \*The running current, the input power, the efficiency and the noise are based on the rating airflow, and 230V/50Hz, 220V/60Hz.
- \*For the specification at the other frequency contact your dealer.
- \*Use this unit with static pressure 250Pa or less at Fan speed4. Otherwise the noise level might be larger.

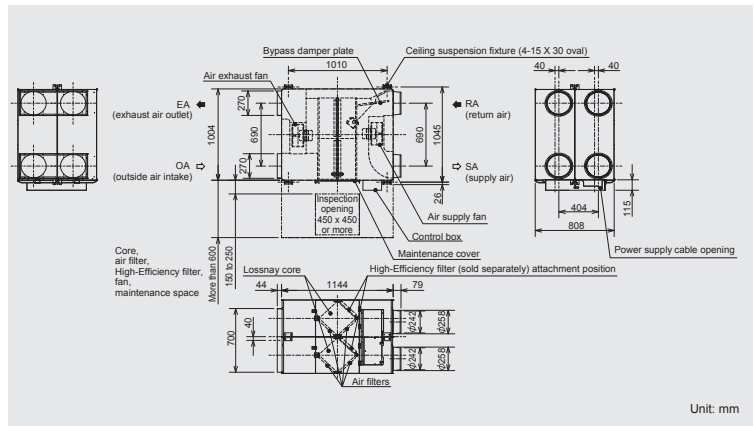
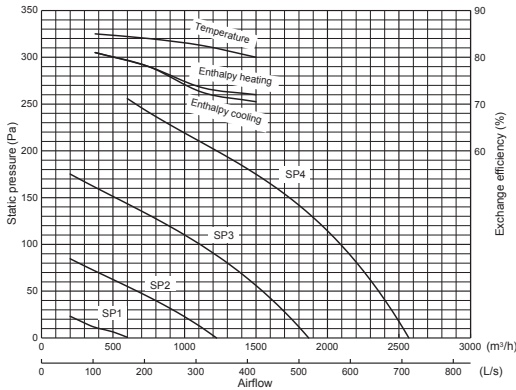

Model		LGH-200RVX-E							
Electrical power supply		220-240V/50Hz, 220V/60Hz							
Ventilation mode		Heat recovery mode				Bypass mode			
Fan speed		SP4	SP3	SP2	SP1	SP4	SP3	SP2	SP1
Running current (A)		4.88	2.20	0.88	0.33	4.54	2.06	0.87	0.35
Input power (W)		850	400	153	42	853	372	150	49
Airflow	(m³/h)	2000	1500	1000	500	2000	1500	1000	500
	(L/s)	556	417	278	139	556	417	278	139
External static pressure (Pa)		150	84	38	10	150	84	38	10
Temperature exchange efficiency (%)	Heating	80.0	83.0	86.5	89.5	—	—	—	—
	Cooling	71.5	78.0	85.0	89.5	—	—	—	—
Enthalpy exchange efficiency (%)	Heating	72.5	74.0	78.0	87.0	—	—	—	—
	Cooling	71.0	73.0	77.0	85.5	—	—	—	—
Noise (dB) (Measured at 1.5m under the center of unit in an anechoic chamber)		40.0	36.0	28.0	18.0	41.0	36.0	27.0	19.0
Weight (kg)		110							

- \*The Air outlets noise (45° angle, 1.5meters in front of the unit) is about 21dB greater than the indicated value.(at Fan speed 4)
- \*The running current, the input power, the efficiency and the noise are based on the rating airflow, and 230V/50Hz, 220V/60Hz.
- \*For the specification at the other frequency contact your dealer.
- \*Use this unit between static pressure 50Pa and 220Pa at Fan speed4. Otherwise the motor protection may work and reduce its output or the noise level might be larger.

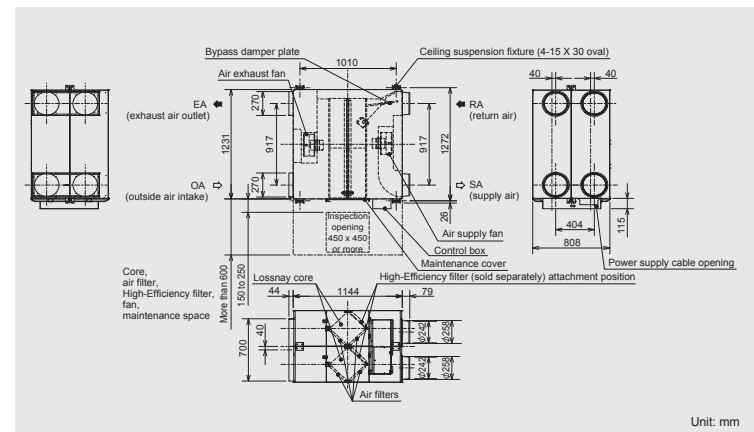
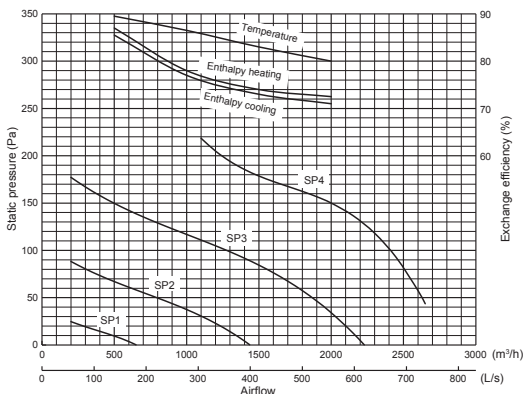



## Optimised System Integration

### List of Remote Controller Settings and Functions

The remote controller provides a wide range of functions and features other than the main functions described below, such as sophisticated energy saving control and easy user interface.

Function (Communicating mode)	PZ-61DR-E	PZ-43SMF-E
Fan speed selection	4 fan speeds	2 of 4 fan speeds
Ventilation mode selection	Energy recovery / Bypass / Auto	Energy recovery / Bypass / Auto
Night-purge (time)	Any time selectable	No
Night-purge (fan speed)	Selectable from 4 fan speeds	No
Dip-switch setting and function setting from RC	Yes	No
Bypass temp. free setting	Yes	No
Heater-On temp. free setting	Yes	No
Fan power up after installation	Yes	No
0 - 10VDC external input	Yes	Yes
ON/OFF timer	Yes	Yes
Auto-Off timer	Yes	No
Weekly timer	Yes	No
Operation restrictions (ON/OFF, Ventilation mode, fan speed)	Yes	No
Operation restrictions (Fan speed skip setting)	Yes	No
Screen contrast adjustment	Yes	No
Language selection	Yes (8 languages)	No (English only)
Initializing remote controller	Yes	No
Filter cleaning sign	Yes	Yes
Lossnay core cleaning sign	Yes	No
Error indication	Yes	Yes
Error history	Yes	No
OA/RA/SA temp. display	Yes	No

# Controllers

## LOSSNAY remote controller (PZ-61DR-E)

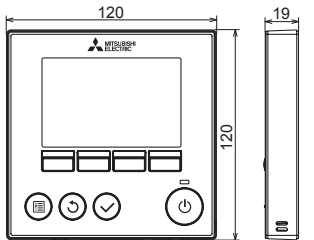

Unit:mm

### Operation section

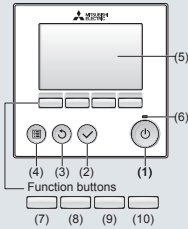

- (1) Press to turn ON/OFF the Lossnay unit.
- (2) Press to save the setting.
- (3) Press to return to the previous screen.
- (4) Press to bring up the Main menu.
- (5) Operation settings will appear.  
When the backlight is off, pressing any button turns the backlight on and it will stay lit for a certain period of time depending on the screen.
- (6) This lamp lights up in green while the unit is in operation. It blinks while the remote controller is starting up or when there is an error.
- (7) Main menu : Press to move the cursor down.
- (8) Main display : Press to change the fan speed.  
Main menu : Press to move the cursor up.
- (9) Main display : Press to change the ventilation mode.  
Main menu : Press to go to the previous page.
- (10) Main menu : Press to go to the next page.

### Display section

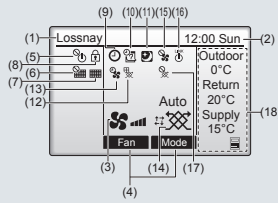

- (1) Lossnay is always displayed.
- (2) Current time appears here
- (3) Fan speed setting appears here.
- (4) Functions of the corresponding buttons appear here.
- (5) Appears when the ON/OFF operation is centrally controlled.
- (6) Appears when the filter reset function is centrally controlled.
- (7) Indicates when filter and/or Lossnay core needs maintenance.
- (8) Appears when the buttons are locked and/or a fan speed is skipped.
- (9) Appears when the On/Off timer, or Auto-off timer function is enabled.
- (10) Appears when the Weekly timer is enabled.
- (11) Appears when the night-purge function is available.
- (12) Appears when performing operation to protect the equipment.
- (13) Appears when performing the power supply/exhaust function or the delay operation at the start of operation.
- (14) Indicates the ventilation mode setting.
- (15) Appears when external fan speed operation.
- (16) Appears when operation interlocked with external unit.
- (17) Appears when external ventilation mode operation.
- (18) Displays the outdoor temperature, return temperature, and supply temperature (calculated value).

## LOSSNAY remote controller (PZ-43SMF-E)

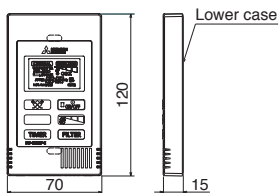

Unit:mm

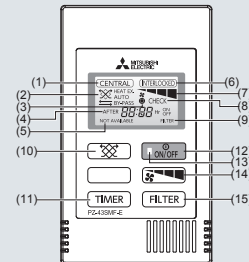

- (1) Displayed during remote operation prohibited by centralised control unit, etc.
- (2) Displays the ventilation mode status.

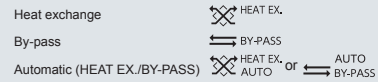

- (3) Displayed while the Lossnay remote controller is powered on.
- (4) Displays on-timer or off-timer duration.
- (5) When a button is pressed for a function which the Lossnay unit cannot perform, this display flashes concurrently with the display of the function.
- (6) Displayed when the Lossnay starts off by interlocked indoor unit or external signal.
- (7) Displays the selected fan speed.
- (8) Displayed together with the malfunctioning unit (3 digits) and an error code (4 digits).
- (9) Displayed when the accumulated operating time reaches the time set for filter maintenance.
- (10) Used to select the ventilation mode among heat exchange, by-pass or automatic.
- (11) Increasing 0:30 by pressing it once. Keep pressing the button for fast-forwarding.
- (12) Switch for start and stop.
- (13) On during operation. Flashes when a malfunction occurs.
- (14) Used to select the fan speed either "Low" or "High".

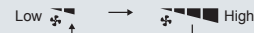

- (15) Press twice to reset the filter sign display.

# Filters

## Standard filters

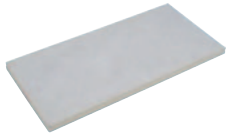

Filter					Lossnay	
Filter material	Classification		Model name	Included piece/set	Applicable model	Required filter pieces
	ISO 16890	EN779 (2012)				
Non-woven fabrics	Coarse 35%	G3 *	PZ-15RF <sub>0</sub> -E	2	LGH-15RVX-E	2
			PZ-25RF <sub>0</sub> -E	4	LGH-25RVX-E	4
			PZ-35RF <sub>0</sub> -E	4	LGH-35RVX-E	4
			PZ-50RF <sub>0</sub> -E	4	LGH-50RVX-E, GUF-50RD4, GUF-50RDH4	4
			PZ-65RF <sub>0</sub> -E	4	LGH-65RVX-E	4
			PZ-80RF <sub>0</sub> -E	LGH-80RVX-E	4	
				LGH-150RVX-E	8	
PZ-100RF <sub>0</sub> -E	4	LGH-100RVX-E, GUF-100RD4, GUF-100RDH4	4			
		LGH-200RVX-E	8			

\* The classification in EN779 (2002) is G3.

## High-efficiency filters Optional



Filter					Lossnay	
Filter material	Classification		Model name	Included piece/set	Applicable model	Required filter pieces
	ISO 16890	EN779 (2012)				
Synthetic fiber	ePM <sub>10</sub> 75%	M6 *	PZ-15RFM-E	1	LGH-15RVX-E	1
			PZ-25RFM-E	2	LGH-25RVX-E	2
			PZ-35RFM-E	2	LGH-35RVX-E	2
			PZ-50RFM-E	2	LGH-50RVX-E, GUF-50RD4, GUF-50RDH4	2
			PZ-65RFM-E	2	LGH-65RVX-E	2
			PZ-80RFM-E	LGH-80RVX-E	2	
				LGH-150RVX-E	4	
PZ-100RFM-E	2	LGH-100RVX-E, GUF-100RD4, GUF-100RDH4	2			
		LGH-200RVX-E	4			

\* The classification in EN779 (2002) is F7.

## Advanced high-efficiency filters Optional



Filter					Lossnay		
Filter material	Classification		GB/T 14295 (2008)	Model name	Included piece/set	Applicable model	Required filter pieces
	ISO 16890	ASHRAE52.2 (2017)					
Synthetic fiber	ePM <sub>1</sub> 75% ePM <sub>2.5</sub> 80% ePM <sub>10</sub> 95%	MERV16	YG class 99.7% *	PZ-15RFP <sub>2</sub> -E	1	LGH-15RVX-E	1
				PZ-25RFP <sub>2</sub> -E	2	LGH-25RVX-E	2
				PZ-35RFP <sub>2</sub> -E	2	LGH-35RVX-E	2
				PZ-50RFP <sub>2</sub> -E	2	LGH-50RVX-E, GUF-50RD4, GUF-50RDH4	2
				PZ-65RFP <sub>2</sub> -E	2	LGH-65RVX-E	2
				PZ-80RFP <sub>2</sub> -E	LGH-80RVX-E	2	
					LGH-150RVX-E	4	
PZ-100RFP <sub>2</sub> -E	2	LGH-100RVX-E, GUF-100RD4, GUF-100RDH4	2				
		LGH-200RVX-E	4				

\* Collecting efficiency for particles that are 0.5 µm or larger at rated airflow.

# OA Processing Units

## GUF-RDH4-Series



### Ideal Indoor-Air Quality — For Your Comfort and Health

The OA (outdoor-air) Processing Unit creates an optimum indoor-air environment at an unparalleled rate of cost efficiency providing substantial energy savings. Forced air ventilating and humidifying functions unique to this system keep indoor-air fresh and free of contaminants preventing “sick building syndrome” and the spread of airborne viruses such as the flu. Another novel feature of the OA Processing Unit is the “Lossnay core,” a heat-exchange unit that functions to transfer heat efficiently, cutting ventilation load by as much as 70%\*. This special combination of functionality and performance designed to ensure users ample comfort and year-round health which cannot be found anywhere else on the market.

\*Model:GUF-100RDH4  
Condition:Heating

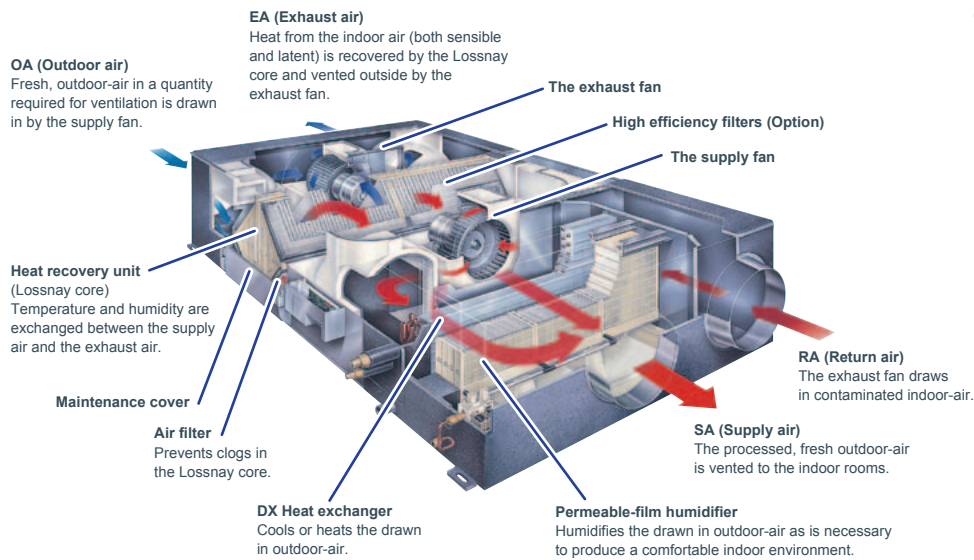

### Permeable Film Humidifier (RDH4 model)

#### Comfortable Level of Humidity for Exceptionable Air Quality

The OA Processing Unit is equipped with a permeable film humidifier developed by Mitsubishi Electric. Steam transmission efficiency has been improved remarkably by lowering the resistance of the material. By providing an optimum level of humidity, the OA Processing Unit creates a comfortable interior environment preventing irritations such as dried out eyes or a parched throat that can be caused by insufficiently low levels of humidity in the air.

#### Highly Efficient Humidification

Improvements in the system of airflow patterns and water injection techniques have resulted in a substantial increase in humidifying volume. The system also controls the humidity level of the air that is exhausted, ensuring an efficient, environmentally friendly manner of operation.

Note: In the case in which the level of residual impurities exceeds 100mg/l please use a water purifier

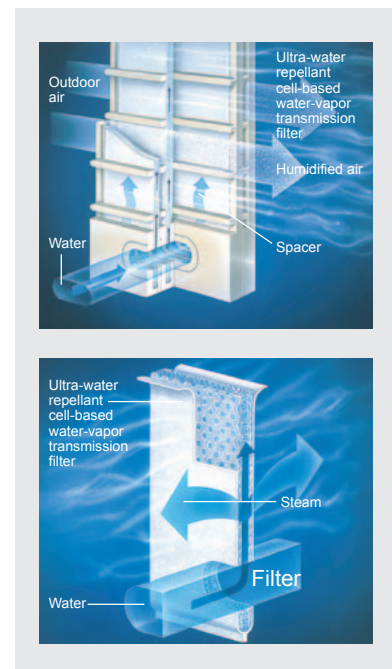

Advantages of CITY MULTI

Outdoor/Heat source unit

Indoor unit

Remote Controller

Lossnay

Installation information

# GUF-RD4-Series

## A Total Air Conditioning Package Manifesting Remarkable Power

### Lossnay Ventilation and Air Conditioning

The OA (outdoor-air) Processing Unit creates an optimum environment while providing substantial energy savings. The OA Processing Unit comprises forced air ventilation, heat recovery, heating and cooling, and air purification. This total air conditioning system keeps indoor air fresh and comfortable all year round, and keeps it free of contaminants preventing ailments such as sick building syndrome. Inside the OA Processing Unit is the Lossnay Core, a heat-exchange unit that transfers heat efficiently, cutting ventilation load by as much as 70%. This special combination of functionality and performance contained within a single unit ensures users ample comfort, good health, and energy savings.

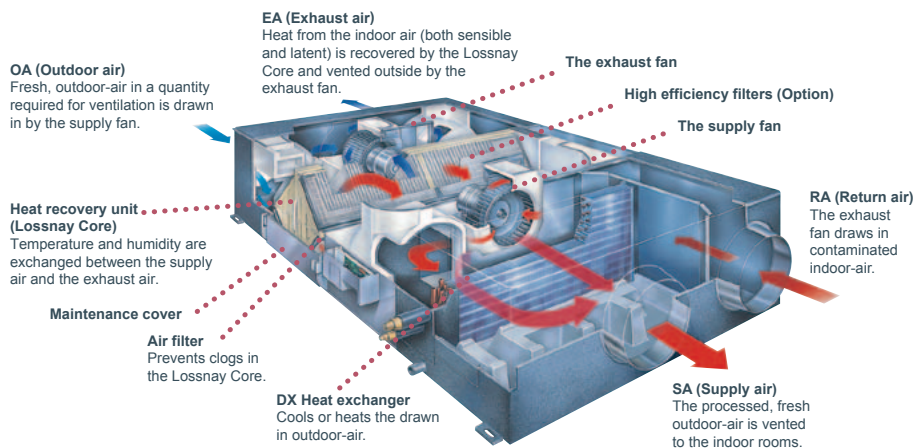

## The Air Conditioning Function

### Two Units in One

Along with Lossnay ventilation, the OA Processing Unit is really two units in one, functioning as the main air conditioner when the load is light and adding supplemental air conditioning when the load is heavy. Also, with ventilation and air conditioning integrated, space is saved and installation expense kept to a minimum. What's more, the air temperature in any room can be perfectly adjusted to the desired

temperature of the occupants via the OA Processing Unit, which can be used as the indoor unit of the CITY MULTI air conditioning system. The heat recovery function maximizes efficiency and saves energy, benefiting the environment and helping companies cut costs. It also reduces the refrigerant load and lowers the amount of horsepower required by the outdoor unit.

Temperature simulation (Example : GUF-50RD4)

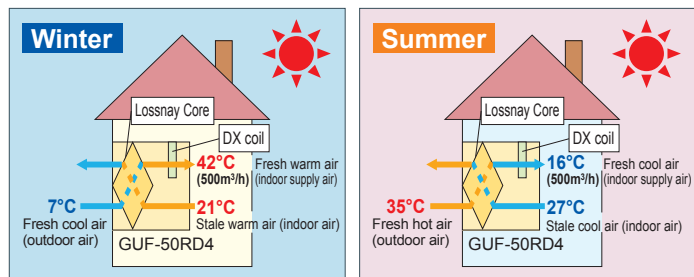



## Specification

Model			GUF-50RDH4	GUF-100RDH4	GUF-50RD4	GUF-100RD4	GUF-100RDH4-60	
Power source			1-phase 220-240V 50Hz				1-phase 220V 60Hz	
Cooling capacity	kW		5.57 <1.94>	11.44 <4.12>	5.57 <1.94>	11.44 <4.12>	11.44 <4.12>	
	kcal / h		4,800 <1,650>	9,800 <3,500>	4,800 <1,650>	9,800 <3,500>	9,800 <3,500>	
	BTU / h		19,000 <6,600>	39,000 <14,000>	19,000 <6,600>	39,000 <14,000>	39,000 <14,000>	
Power input		W	235-265	480-505	235-265	480-505	685	
Current input		A	1.15	2.20	1.15	2.20	3.20	
Heating capacity	kW		6.21 <2.04>	12.56 <4.26>	6.21 <2.04>	12.56 <4.26>	12.56 <4.26>	
	kcal / h		5,340 <1,750>	10,800 <3,650>	5,340 <1,750>	10,800 <3,650>	10,800 <3,650>	
	BTU / h		21,200 <7,000>	42,850 <14,450>	21,200 <7,000>	42,850 <14,450>	42,850 <14,450>	
Power input		W	235-265	480-505	235-265	480-505	685	
Current input		A	1.15	2.20	1.15	2.20	3.20	
Capacity equivalent to indoor unit			P32	P63	P32	P63	P63	
Humidifying capacity		kg / h	2.7	5.4	—	—	5.4	
		lbs / h	6.0	12.0	—	—	12.0	
Humidifier			Permeable film humidifier				—	
External finish			Galvanized, with grey insulation sheet					
External dimension H x W x D		mm	317 x 1,016 x 1,288	398 x 1,231 x 1,580	317 x 1,016 x 1,288	398 x 1,231 x 1,580	398 x 1,231 x 1,580	
		in.	12-1/2 x 40 x 50-3/4	15-11/16 x 48-1/2 x 62-1/4	12-1/2 x 40 x 50-3/4	15-11/16 x 48-1/2 x 62-1/4	15-11/16 x 48-1/2 x 62-1/4	
Net weight		kg (lbs)	51 (112)	88 (194)	48 (106)	82 (181)	88 (194)	
Heat exchanger		LOSSNAY core	Partition, Cross-flow structure, Special preserved paper-plate.					
		Refrigerant coil	Cross fin (Aluminum fin and copper tube)					
FAN		Type x Quantity	SA: Centrifugal fan (Sirocco fan) x 1 EA: Centrifugal fan (Sirocco fan) x 1					
		External static press.	Pa	125	135	140	140	115
			mmH <sub>2</sub> O	12.7	13.8	14.3	14.3	11.7
Motor type		Totally enclosed capacitor permanent split-phase induction motor, 4 poles, 2units						
Motor output		kW	—	—	—	—	—	
Driving mechanism		Direct-driven by motor						
Airflow rate (High value)		m <sup>3</sup> / h	500	1,000	500	1,000	1,000	
		L / s	139	278	139	278	278	
		cfm	294	589	294	589	589	
Sound pressure level (Low-High) (measured in anechoic room)		dB <A>	33.5-34.5	38-39	33.5-34.5	38-39	40.5	
Insulation material			Polyester sheet					
Air filter		Supplying air	Non-woven fabrics filter (Gravitational method 82%) & Optional part: High efficiency filter (Colorimetric method 65%)					
		Exhausting air	Non-woven fabrics filter (Gravitational method 82%)					
Protection device			Fuse					
Refrigerant control device			LEV					
Connectable outdoor unit			R410A CITY MULTI					
Diameter of refrigerant pipe		Liquid	mm (in.)	ø6.35 (ø1/4) Flare	ø9.52 (ø3/8) Flare	ø6.35 (ø1/4) Flare	ø9.52 (ø3/8) Flare	ø9.52 (ø3/8) Flare
		Gas	mm (in.)	ø12.7 (ø1/2) Flare	ø15.88 (ø5/8) Flare	ø12.7 (ø1/2) Flare	ø15.88 (ø5/8) Flare	ø15.88 (ø5/8) Flare

### Notes:

#### ■ For GUF Series

\*Cooling/Heating capacity indicates the maximum value at operation under the following condition.

Cooling: Indoor: 27°C DB/19°C WB Outdoor: 35°C DB/24°C WB

Heating: Indoor: 20°C DB/13.8°C WB Outdoor: 7°C DB/6°C WB

\*The figures in < > indicates heat recovering capacity of heat exchange core.

\*Figures in the chart is measured according to Japan Industrial Standard (JIS B 8628). Characteristic Curves are measured by chamber method.

\*When the total capacity of indoor units connected to 1 outdoor unit (PUHY or PUCY) exceeds the capacity of the outdoor unit, the total capacity of GUF needs to be 30% and less of the connected outdoor unit capacity.

# Installation information

\*Refer to the enclosed Installation Manual for details on installation. Arrange to have an expert install the system correctly.

## 1. General precautions

### 1-1. Usage

- The air-conditioning system described in this catalogue is designed for human comfort.
- This product is not designed to assist in the preservation of food, provide conditions to maintain plants or animals, or stabilize environments for the preservation of precision equipment or art objects. To prevent loss of quality, do not use the product for purposes other than those it is designed for.
- To reduce the risk of water leakage and electric shock, do not use the product for air-conditioning vehicles or vessels.

### 1-2. Installation environment

- Do not install any unit other than the dedicated unit in an area where the voltage changes significantly, large amounts of mineral oil (e.g., cutting oil) are present, cooking oil may splash, or a large quantity of steam can be generated, such as a kitchen.
- Do not install the unit in acidic or alkaline environments.
- Installation should not be performed in locations exposed to chlorine or other corrosive gases. Avoid installation near sewers.
- To reduce the risk of fire, do not install the unit in an area where flammable gas may leak or flammable material is present.
- This air-conditioning unit has a built-in microcomputer. The effects of noise should be taken into consideration when deciding on the installation position. It is recommended that the air-conditioning unit be installed in a position away from antennas or electronic devices.
- Install the unit on a solid foundation in accordance with local safety measures against typhoons, wind gusts, and earthquakes to prevent the unit from being damaged, toppling over, or falling.

### 1-3. Backup system

- In regions in which the malfunctioning of the air conditioner may have a critical effect, it is recommended to have two or more systems made up of single outdoor/heat source units and multiple indoor units.

### 1-4. Unit characteristics

- The heat pump efficiency of the outdoor unit depends on the outdoor temperature. In heating mode, performance drops as the outside air temperature drops. In cold climates, performance can be poor. Warm air will continue to be trapped near the ceiling and the floor level will remain cold. In such cases, heat pumps require a supplemental heating system or air circulator. Before purchasing, consult your local distributor for assistance in selecting the unit and system.
- When the outdoor temperature is low and the humidity is high, the heat exchanger on the outdoor/heat source unit side tends to collect frost, which reduces its heating performance. The Auto-defrost function will be activated in order to remove the frost, and the heating mode will temporarily stop for 3-10 minutes. Heating mode will automatically resume upon completion of the defrost process.
- An air conditioner with a heat pump requires time to warm up the whole room after the heating operation begins, because the system circulates warm air in order to warm up the whole room.
- Sound levels were obtained in an anechoic room. Sound levels during actual operation are usually higher than the simulated values due to ambient noise and echoes. Refer to the section on "SOUND LEVELS" in the DATA BOOK for the measurement location.
- Depending on the operating conditions, the unit generates noise caused by valve actuation, refrigerant flow, and pressure changes even when operating normally. Try to avoid positioning the air conditioner in locations where quietness is required.  
With regard to the BC controller, it is recommended that the unit be installed in areas such as corridor ceilings, restrooms and plant rooms.
- The total capacity of the connected indoor units can be greater than the capacity of the outdoor/heat source unit. However, when the connected indoor units operate simultaneously, each unit's capacity may become smaller than the rated capacity.

- When the unit is started up for the first time within 12 hours after the power comes on, i.e. after a power failure, it performs initial startup operation (capacity control operation) to prevent damage to the compressor. The initial startup operation requires a maximum of 90 minutes to complete, depending on the operating load.
- When the unit is operating out of the operation temperature range, the unit may stop to prevent malfunction.

### 1-5. Related equipment

- Use an earth leakage breaker (ELB) with medium sensitivity, and an activation speed of 0.1 second or less.
- Consult your local distributor or a qualified technician when installing an earth leakage breaker.
- If the unit is an inverter type, select an earth leakage breaker able to respond to high harmonic waves and surges.
- Leakage current is generated not only through the air-conditioning unit but also through the power wires. The leakage current of the main power supply is therefore greater than the total leakage current of each unit. Take the capacity of the earth leakage breaker or leakage alarm into consideration when installing one at the main power supply. To measure the leakage current simply on site, use a measurement tool equipped with a filter, and clamp all the four power wires together. The leakage current measured on the ground wire may not be accurate because the leakage current from other systems may be included in the measurement value.
- Do not install a phase-advancing capacitor on a unit connected to the same power system as an inverter-type unit and its related equipment.
- If a large current flows due to the malfunctioning of the product or faulty wiring, both the earth leakage breaker on the product side and the upstream overcurrent breaker may trip almost at the same time. Separate the power system or coordinate all the breakers depending on the system's priority level.

### 1-6. Unit installation

- Your local distributor or a qualified technician must read the Installation Manual that is provided with each unit carefully before performing installation work.
- Consult your local distributor or a qualified technician when installing the unit. Improper installation by an unqualified person may result in water leakage, electric shock, or fire.
- Ensure that there is enough space around each unit.

### 1-7. Optional accessories

- Only use accessories recommended by Mitsubishi Electric. Consult your local distributor or a qualified technician when installing them. Improper installation by an unqualified person may result in water leakage, power leakage, system breakdown, or fire.
- Some optional accessories may not be compatible for use with the air-conditioning unit or may not be suitable for the installation conditions. Check the compatibility when considering any accessories.
- Note that some optional accessories may affect the air conditioner's external form, appearance, weight, operating sound, and other characteristics.

### 1-8. Operation/Maintenance

- Read the Instruction Book that is provided with each unit carefully prior to use.
- Maintenance or cleaning of each unit may be risky and require expertise. Read the Instruction Book to ensure safety. Consult your local distributor or a qualified technician when special expertise is required, such as when the indoor unit needs to be cleaned.

## 2. Precautions for Indoor unit

### 2-1. Operating environment

- The refrigerant (R410A) used in the air conditioner is non-toxic and nonflammable. However, if the refrigerant leaks, the oxygen level may drop to harmful levels. If the air conditioner is installed in a small room, measures must be taken to prevent the refrigerant concentration from exceeding the safety limit even if the refrigerant leaks.
- If the units operate in cooling mode at a humidity above 80%, condensation may collect and drip from the indoor units.
- Regular checking and cleaning of the drain drainage paths, such as the drain pan or the drain pump, is recommended to prevent clogging. The neglect of a clogged drain pump may trigger the water-leakage protection function which stops operation of the entire system.

### 2-2. Unit characteristics

- The return air temperature display on the remote controller may differ from the displays on the other thermometers.
- The clock on the remote controller may be displayed with a time lag of approximately one minute every month.
- The temperature measured by the built-in temperature sensor on the remote controller may differ from the actual room temperature due to the effect of the wall temperature.
- Use the built-in thermostat on the remote controller or a separately-sold thermostat when indoor units installed on or in the ceiling operate the automatic cooling/heating switchover.
- The room temperature may rise drastically due to Thermo OFF in areas where the air-conditioning load is large, such as computer rooms.
- Be sure to use a regular filter. If an irregular filter is installed, the unit may not operate properly, and operating noise may increase.
- The room temperature may increase above the preset temperature in environments in which the heating or air-conditioning load is small.

### 2-3. Unit installation

- Do not have any branching points on the downstream of the refrigerant pipe header.
- When a field-supplied external thermistor is installed or when a device for demand control is used, the unit may stop abnormally or damage may occur to the electromagnetic contactor. Consult your local distributor for details.
- When indoor units employ fresh air intake, install a filter in the duct (locally procured) to remove dust from the air.
- The 4-way or 2-way Airflow Ceiling Cassette Type units that have an outside air inlet can be connected to the duct, but need a booster fan to be installed at site. Refer to the chapter "Indoor Unit" in the DATA BOOK for the available range for fresh air intake volume.
- Employing fresh air intake for the indoor unit may increase the sound pressure level.
- When installing the ceiling concealed type, secure enough access space to allow for the maintenance according to the installation manual.
- Do not install the unit above the cooking or food processing area.

### 2-4. Noise level (Sound pressure level)

- The sound pressure level is a value measured in an anechoic room in accordance with the conventional method in JIS standard. The sound pressure level actually measured at the installation site is usually higher than the value indicated in this catalogue due to the influence of ambient noise and echoes.

<Measurement location>

- PLFY-P-VEM-PA, PLFY-P-VFM-E1, PLFY-P-VLMD-E, PMFY-P-VBM-E, PMFY-P-VFM-PA

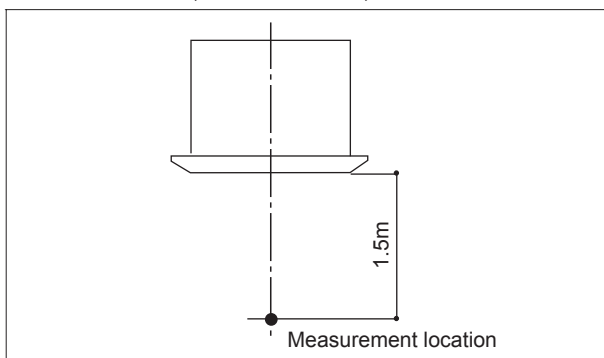

- PEFY-P-VMR-E-L/R, PEFY-P-VMS1(L)-E, PEFY-P-VMH(S)-E, PEFY-P-VMH(S)-E-F

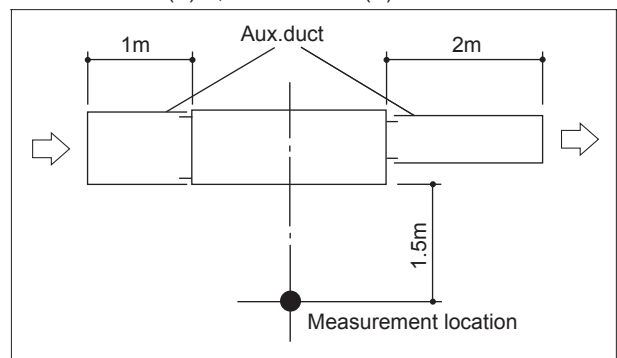

■ PEFY-P-VMA(L)-E4, PEFY-P-VMA4-E, PEFY-P-VMA3-E

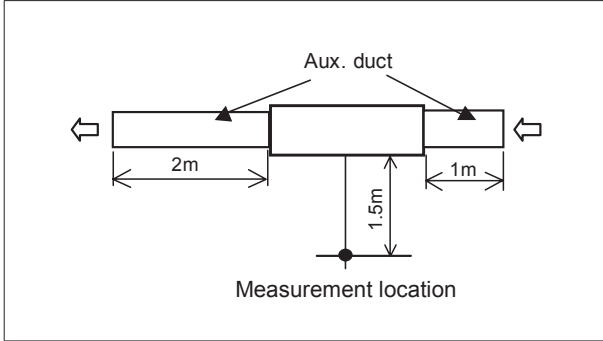

■ PCFY-P-VKM-E

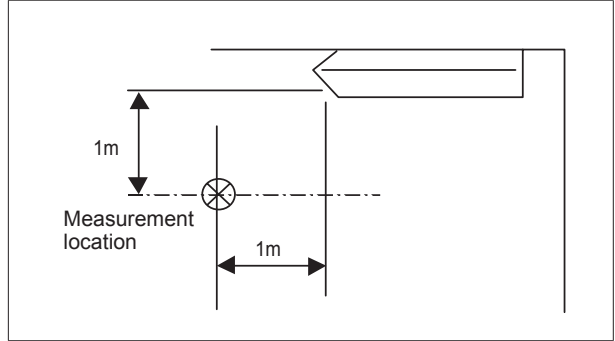

■ PKFY-P-VLM-E, PKFY-P-VKM-E

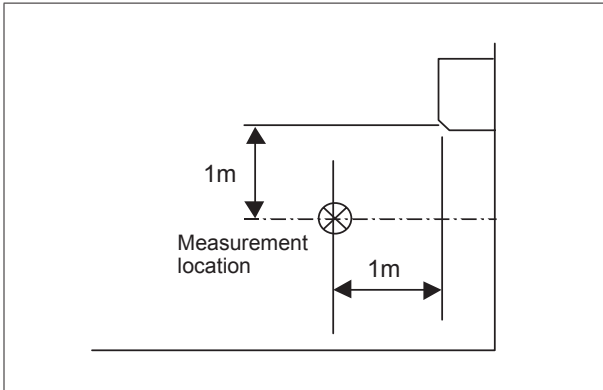

■ PFFY-P-VKM-E2, PFFY-P-VLEM-E

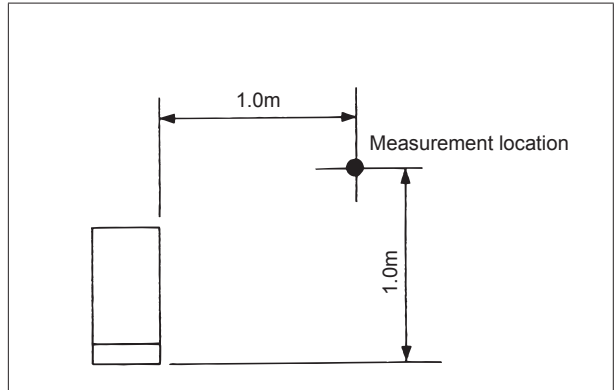

■ PFFY-P-VCM-E

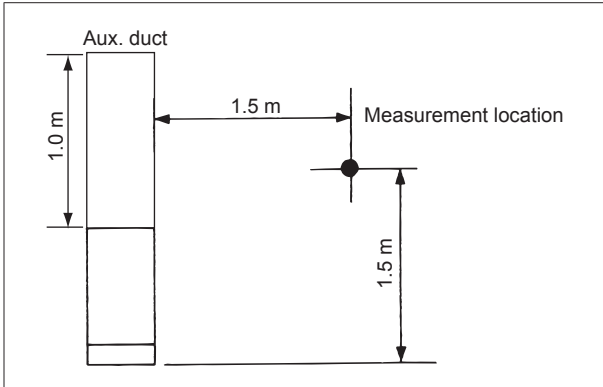

■ PFFY-P-YM(H)-E, PFFY-P-YM-E-F

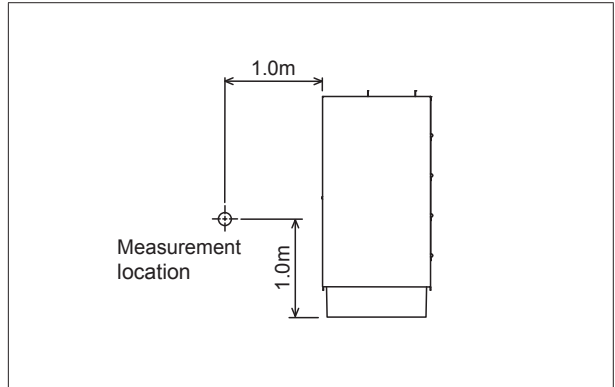



## 3. Precautions for Outdoor unit/Heat source unit

### 3-1. Installation environment

- The outdoor unit with the salt-resistant specification is recommended for use in an area in which it will be exposed to salt air.
- Even when the unit with the salt-resistant specification is used, it is not completely protected against corrosion.  
Be sure to follow the directions or precautions described in the Instruction Book and Installation Manual for installation and maintenance. The salt-resistant specification is referred to in the guidelines published by JRAIA (JRA9002).
- Install the unit in an area where the flow of discharge air is not obstructed. If the flow of discharge air is obstructed, short-cycling of discharge air may occur.
- Provide proper drainage around the base of the units; condensation may collect and drip from outdoor units.  
Provide water-proofing protection to the floor when installing the unit on the rooftop.
- In regions where snowfall can be expected, install the unit so that the outlet faces away from the direction of the wind, and install a snow guard to protect the unit from snow. Install the unit on a base approximately 50 cm higher than the expected snowfall. Close the openings for pipes and wiring, because the ingress of water and small animals may cause equipment damage. If a SUS snow guard is used, refer to the Installation Manual that comes with the snow guard and be careful with the installation to avoid the risk of corrosion.
- When the unit is expected to operate continuously for a long period of time at outside air temperatures of below 0°C, take appropriate measures, such as the use of a unit base heater, to prevent ice forming on the unit base. (Not applicable to the PUMY-Series)
- Install the snow guard so that the outlet/inlet faces away from the direction of the wind.
- When approximately 50 cm or more of snow accumulates on the snow guard, remove the snow from the guard. Install a roof that is strong enough to withstand loads caused by snow in areas where snow accumulates.
- Provide proper protection around the outdoor units in places such as schools to avoid the risk of injury.
- A cooling tower and heat source water circuit should be a closed circuit so that water is not exposed to the atmosphere.  
When a tank is installed to ensure that the circuit has enough water, minimize the contact with outside air to ensure that the oxygen dissolved in the water is 1 mg/L or less.
- Install a strainer (50 mesh or more recommended) on the water pipe inlet on the heat source unit.
- Interlock the heat source unit and water circuit pump.
- Note the following to prevent the freezing and bursting of pipes when the heat source unit is installed in an area where the ambient temperature can be 0°C or below.
  - ◆ Keep the water circulating to prevent it from freezing when the ambient temperature is 0°C or below.
  - ◆ Before a long period of non-use, be sure to purge the water from the unit.
- The salt-resistant unit is resistant to salt corrosion, but not salt-proof.

Please note the following when installing and maintaining outdoor units in a marine environment.

1. Install the salt-resistant unit in an area in which it is not directly exposed to sea breezes, and minimize exposure to salt water mist.
2. Avoid installing a sun shade over the outdoor unit, so that rain will wash away salt deposits off the unit.
3. Install the unit horizontally to ensure proper water drainage from the base of the unit. Accumulation of water in the base of the outdoor unit will significantly accelerate corrosion.
4. Periodically wash salt deposits off the unit, especially when the unit is installed in a coastal area.
5. Repair all noticeable scratches after installation and during maintenance.
6. Periodically check the unit, and apply an anti-rust agent and replace corroded parts as necessary.

### 3-2. Circulating water

- Regularly check the quality of the water in the heat source unit, following the guidelines published by JRAIA (JRA-GL02-1994).
- A cooling tower and heat source water circuit should be a closed circuit so that water is not exposed to the atmosphere. When a tank is installed to ensure that the circuit has enough water, minimize the contact with outside air to ensure that the oxygen dissolved in the water is 1 mg/L or less.

### 3-3. Unit characteristics

- When the Thermo ON and OFF is frequently repeated on the indoor unit, the operating status of outdoor/heat source units may become unstable.

### 3-4. Related equipment

- Provide grounding in accordance with the local regulations.

### 3-5. Noise level (Sound pressure level)

- The sound pressure level is a value measured in an anechoic room in accordance with the conventional method in JIS standard. The sound pressure level actually measured at the installation site is usually higher than the indicated value in this catalogue due to the influence of ambient noise and echoes.

Valve operation noise and refrigerant flow noise may occur from inside the outdoor unit/heat-source unit.

<Measurement location>

- PUCY-(E)P-Y(S)KD(-BS), PUHY-(E)P-Y(S)KD(-BS)

PUCY-P200, 250, 300YKD(-BS)

PUHY-P200, 250, 300YKD(-BS)

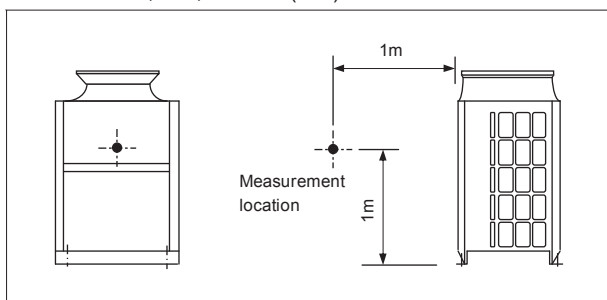

PUCY-P350, 400, 450YKD(-BS)

PUHY-P350, 400, 450YKD(-BS)

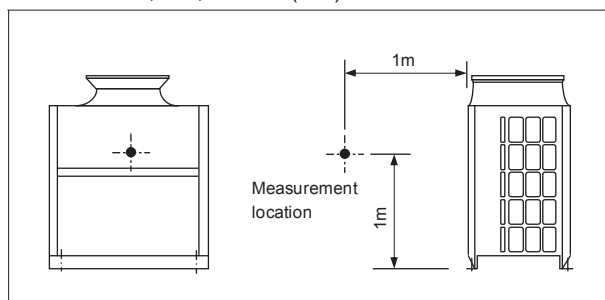

PUCY-P500YKD(-BS)

PUHY-P500YKD(-BS)

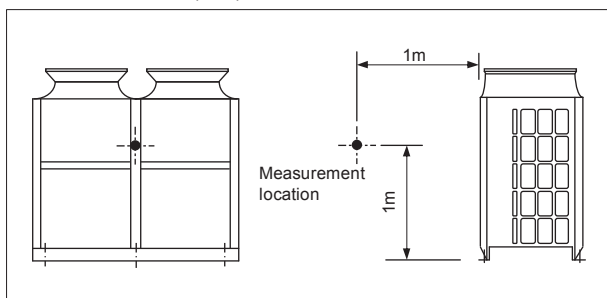

\*See the DATA BOOK for information on the combination models.

■ PQHY-(E)P-Y(S)LM-A1

PQHY-P200, 250, 300YLM-A1

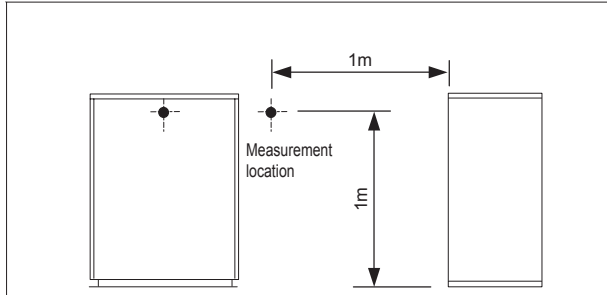

PQHY-P350, 400, 450, 500, 550, 600YLM-A1

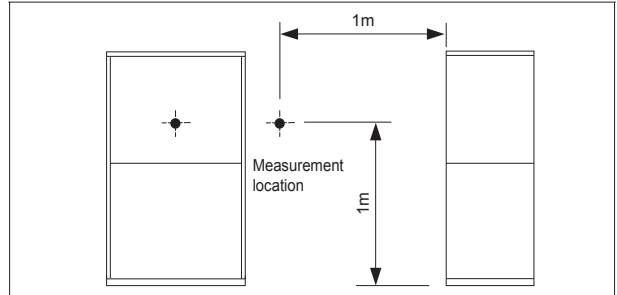

\*See the DATA BOOK for information on the combination models.

■ PUMY-CP-VKM2(-BS), PUMY-CP-YKM2(-BS), PUMY-SP-VKM2(-BS), PUMY-SP-YKM2(-BS), PUMY-P-YKM3(-BS), PUMY-(C)P-YBM2(-BS)

PUMY-CP100, 125, 140VKM2(-BS)

PUMY-CP100, 125, 140, 175, 200, 225YKM2(-BS)

PUMY-CP250, 300YBM2(-BS)

PUMY-SP100, 125, 140VKM2(-BS)

PUMY-SP100, 125, 140YKM2(-BS)

PUMY-P175, 200, 225YKM3(-BS)

PUMY-P250, 300YBM2(-BS)

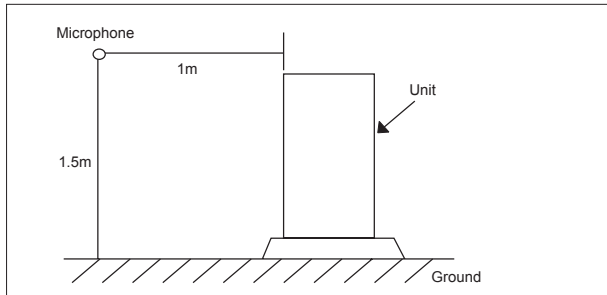

## 4. Precautions for control-related items

### 4-1. Product specification

- To introduce the MELANS system, a consultation with us is required in advance. Especially to introduce the electricity charge-apportioning function or energy save function, further detailed consultation is required.  
Consult your local distributor for details.
- Billing calculation for AE-200E/AE-50E/EW-50E, or the billing calculation unit is unique and based on our original method. (Backup operation is included.) It is not based on the metering method, and do not use it for official business purposes. It is not the method that the amount of electric power consumption (input) by air conditioner is calculated. Note that the electric power consumption by air conditioner is apportioned by using the ratio corresponding to the operation status (output) for each air conditioner (indoor unit) in this method.
- In the apportioned billing function for AE-200E/AE-50E and EW-50E, separate watt-hour meters should be used for A-control units, K-control units, and CITY MULTI packaged air conditioners. It is recommended that an individual watt-hour meter should be used for large-capacity indoor units (with two or more addresses).
- When using the peak cut function on the AE-200E/AE-50E or EW-50E, note that the control is performed once every minute and it takes time to obtain the effect of the control. Take appropriate measures such as lowering the criterion value. Power consumption may exceed the limits if the AE-200E/AE-50E or EW-50E malfunctions or stops. Provide a back-up remedy as necessary.
- The controllers cannot operate while the indoor unit is OFF. (No error)  
Turn ON the power to the indoor unit when operating the controllers.
- When using the interlocked control function on the AE-200E/AE-50E/EW-50E/PAC-YG66DCA or PAC-YG63MCA, do not use the control for fire prevention or security. (This function should never be used in a way that would put people's lives at risk.) Employ any methods or circuits that allow ON/OFF operation using an external switch in case of failure.

### 4-2. Installation environment

- Surge protection may be required for the transmission line in areas where lightning strikes occur frequently.
- The receiver for a wireless remote controller may not work properly due to the effect of general lighting. Leave a space of at least 1 m between the general lighting and the receiver.
- When the auto-elevating panel is used and the system is operated using a wired remote controller, install the wired remote controller in a place where all the air conditioners being controlled (at least the bottom part of them) can be seen from the wired remote controller. If not, the descending panel may cause damage or injury; be sure to use a wireless remote controller designed for use with the elevating panel (sold separately).
- Install the wired remote controller (switch box) in a place where the following conditions are met.
  - ◆ Where the installation surface is flat
  - ◆ Where the remote controller can detect an accurate room temperature  
The temperature sensors that detect the room temperature are installed both in the remote controller and in the indoor unit.  
When the room temperature is detected using the sensor in the remote controller, the main remote controller is used to detect the room temperature. In this case, follow the instructions below.
    - > Install the controller in a place where it is not affected by a heat source.  
(If the remote controller faces direct sunlight or the direction of the supply air flow, the remote controller cannot detect the accurate room temperature.)
    - > Install the controller in a place where the average room temperature can be detected.
    - > Install the controller in a place where no other wires are present around the temperature sensor.  
(If other wires are present, the remote controller cannot detect an accurate room temperature.)
- To prevent unauthorized access, always use a security device such as a VPN router when connecting the AE-200E/AE-50E or EW-50E to the Internet.

# Maintenance Equipment

## Maintenance cycle

**[Note that maintenance cycle does not mean guarantee period.]**

The following tables are applicable when using equipment under the conditions below.

- Normal use without frequent START/STOPS (The number of START/STOPS is assumed to be less than 6 times per hour in normal use.)
- Operating hours are assumed to be 10 hours per day/2500 hours per year.

When the equipment is used under the following conditions, the "maintenance cycle" and "replacement intervals" may be shortened.

- When equipment is used in an environment where temperature and humidity are high or change dramatically
- When equipment is used in an environment where power supply fluctuations (the distortion of voltage, frequency, and waveform) are large (Only within the allowable range)
- When equipment is used in an environment where the unit may receive vibration or mechanical shock
- When equipment is used in an environment where dust, salt, toxic gases such as sulfur dioxide and hydrogen sulfide, and oil mist are present
- When equipment starts/stops frequently and operates for long periods (24-hour air-conditioning operation)

Table 1. Maintenance cycle

Major components	Checking cycle	Maintenance cycle	Major components	Checking cycle	Maintenance cycle
Compressor	1 year	20,000 hours	Expansion valve	1 year	20,000 hours
Motor (Fan, louver, drain pump)		20,000 hours	Valve (solenoid valve, four-way valve)		20,000 hours
Bearings		15,000 hours	Sensor (thermistor, pressure sensor)		5 years
Electric board		25,000 hours	Drain pan		8 years
Heat exchanger		5 years			

Note1 This table shows major components. Refer to the maintenance contract for details.

Note2 This maintenance cycle shows a period in which products are expected to require no maintenance. Use this cycle for planning maintenance (budgeting the maintenance expense etc.) The Checking/ Maintenance cycle may be shorter than the one shown on this table depending on the contents of the maintenance check contract.

- Sudden unpredictable accidents may occur even if check-ups are performed.

## Replacement cycle for consumable components

**[Note that replacement cycle does not mean guarantee period.]**

Table 2. Replacement cycle

Major components	Checking cycle	Replacement cycle
Long-life filter	1 year	5 years
High-performance filter		1 year
Fan belt		5,000 hours
Smoothing capacitor		10 years
Fuse		10 years
Crank case heater		8 years

Note1 This table shows major components. Refer to the maintenance contract for details.

Note2 This replacement cycle shows a period in which products are expected to require no replacement. Use this cycle for planning maintenance (budgeting expenses for replacing equipment, etc.)





 Warning

- Do not use refrigerant other than the type indicated in the manuals provided with the unit and on the nameplate.
  - Doing so may cause the unit or pipes to burst, or result in explosion or fire during use, during repair, or at the time of disposal of the unit.
  - It may also be in violation of applicable laws.
  - MITSUBISHI ELECTRIC CORPORATION cannot be held responsible for malfunctions or accidents resulting from the use of the wrong type of refrigerant.
- Our air-conditioning equipments and heat pumps contain a fluorinated greenhouse gas, R410A.

**MITSUBISHI ELECTRIC CORPORATION**

[www.MitsubishiElectric.com](http://www.MitsubishiElectric.com)